

**LECTURE NOTES**  
**ON**  
**STRENGTH OF MATERIALS**

**III Semester (mechanical engg.)**

**3<sup>rd</sup> semester**

**DEPARTMENT  
OF  
MECHANICAL ENGINEERING**

**G P NAYAGARH  
ODISHA**

## UNIT I

### STRESSES AND STRAINS (SIMPLE & PRINCIPAL)

Stress is proportional to strain within its elastic limit. This law is known as Hooke's law. The material will not return to original shape if the applied stress is more than E.

$$\zeta \propto \varepsilon \quad \text{Stress} - \zeta \quad \text{Linear Strain} - \varepsilon$$

Therefore,  $\zeta = E\varepsilon$       Where E Modulus of Elasticity or Young's Modulus.

$$\zeta = \frac{P}{A} \quad \begin{array}{l} P - \text{Load} \\ A - \text{Area of the section where the load is applied.} \end{array}$$

Stresses are three types tensile, compressive, and shear stress. Moment and torsion will produced any of these stresses.

Strain is nothing but deformation (change in length, breadth, height, diameter, therefore area or volume) of the body or material due to load. Therefore strain is change in dimension to the original dimension. It may be length or volume.

$$\varepsilon = \frac{\delta L}{L} \quad \begin{array}{l} \delta L - \text{Change in length} \\ L - \text{Original length} \end{array}$$

Therefore by substituting the value of  $\zeta$  and  $\varepsilon$  in the Hooke's law. Change in length is

$$\delta L = \frac{PL}{AE} \quad \delta L = \frac{4PL}{Ed^3} \quad \text{uniformly varying circular section } \Pi$$

$$\delta L = \frac{PL}{Et(a-b)} \quad \text{uniformly varying rectangular section } a > b$$

This is the fundamental equation to find change in length of any type of section or step section using principle of superposition method of varying load, length, area, and material. The change in length due to compressive load is taken as negative and positive for tensile load.

#### Units :

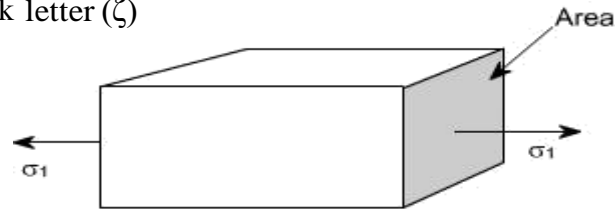
The basic units of stress in S.I units i.e. (International system) are  $N / m^2$  (or Pa) MPa  
 $= 10^6$  Pa GPa =  $10^9$  Pa

KPa =  $10^3$  Pa

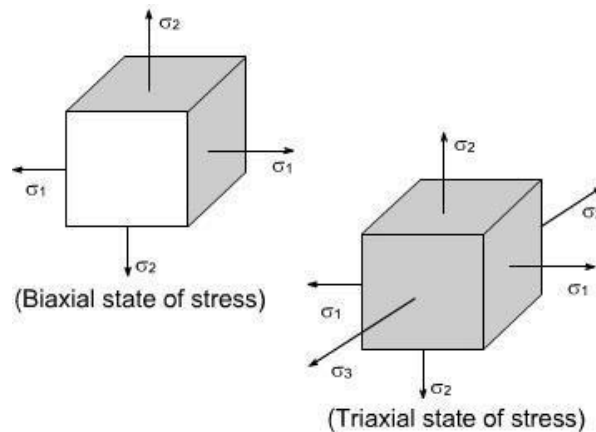
Sometimes  $N / mm^2$  units are also used, because this is an equivalent to MPa. While US customary unit is pound per square inch psi.

**TYPES OF STRESSES :** Only two basic stresses exists : (1) normal stress and (2) shear stress. Other stresses either are similar to these basic stresses or are a combination of this e.g. bending stress is a combination tensile, compressive and shear stresses. Torsional stress, as encountered in twisting of a shaft is a shearing stress. Let us define the normal stresses and shear stresses in the following sections.

**Normal stresses :** We have defined stress as force per unit area. If the stresses are normal to the areas concerned, then these are termed as normal stresses. The normal stresses are generally denoted by a Greek letter ( $\zeta$ )

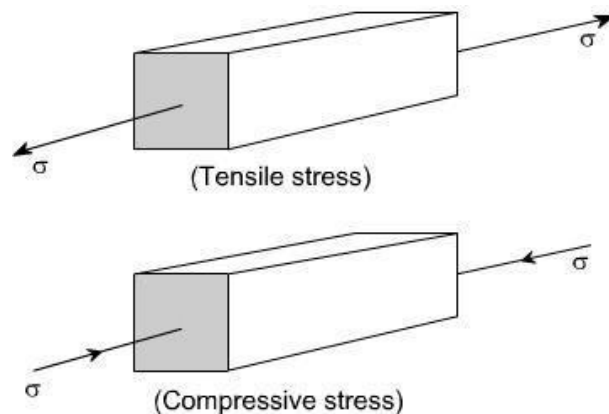


This is also known as uniaxial state of stress, because the stresses acts only in one direction however, such a state rarely exists, therefore we have biaxial and triaxial state of stresses where either the two mutually perpendicular normal stresses acts or three mutually perpendicular normal stresses acts as shown in the figures below :



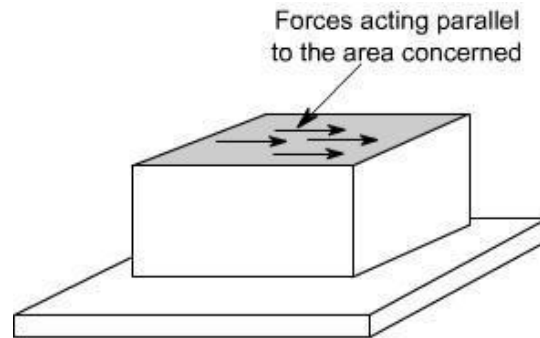
**Tensile or compressive Stresses:**

The normal stresses can be either tensile or compressive whether the stresses acts out of the area or into the area



## Shear Stresses:

Let us consider now the situation, where the cross – sectional area of a block of material is subject to a distribution of forces which are parallel, rather than normal, to the area concerned. Such forces are associated with a shearing of the material, and are referred to as shear forces. The resulting stress is known as shear stress.



## Deformation of a Body due to Self Weight

Consider a bar AB hanging freely under its own weight as shown in the figure.

Let

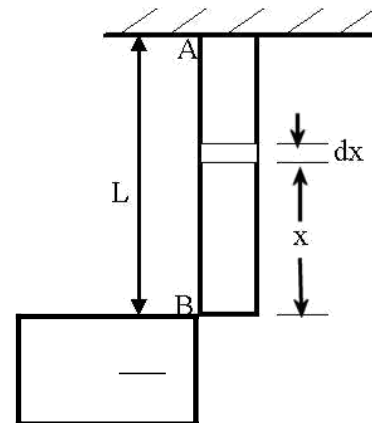
$L$  = length of the bar

$A$  = cross-sectional area of the bar

$E$  = Young's modulus of the bar material  $w$  =

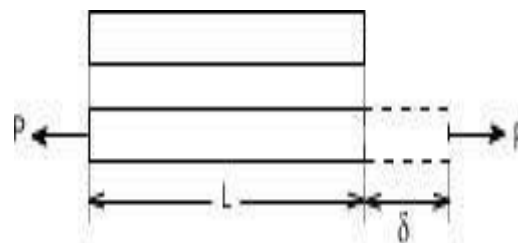
Specific weight of the bar material

Then deformation due to the self-weight of the bar



## Members in Uni – axial state of stress

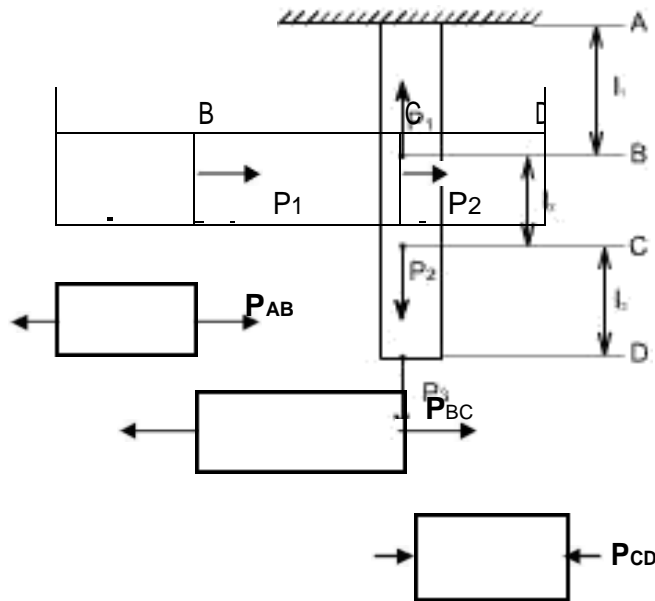
For a prismatic bar loaded in tension by an axial force  $P$ , the elongation of the bar can be determined as



$$\delta = \frac{PL}{AE} \quad \text{--- (1)}$$

Suppose the bar is loaded at one or more intermediate positions, then equation

(1) can be readily adapted to handle this situation, i.e. we can determine the axial force in each part of the bar i.e. parts AB, BC, CD, and calculate the elongation or shortening of each part separately, finally, these changes in lengths can be added algebraically to obtain the total change in length of the entire bar.



### **Principle of Superposition**

The principle of superposition states that when there are numbers of loads are acting together on an elastic material, the resultant strain will be the sum of individual strains caused by each load acting separately.

### **Types of problem**

#### **Both ends are free (to expand or shrink) determinate structure:**

Total change in length is equal to algebraic sum of change in length of each section of its load  $P$ , length  $L$ , Area  $A$ , and Young's modulus  $E$ . These parameters may vary from section to section. The material is free to expand and shrink.

$$\delta L = \delta_1 + \delta_2 + \delta_3 + \dots + \delta_n$$

$P_1$

$\leftarrow P_4$

#### **Both ends are fixed (cannot expand or shrink) indeterminate structure:**

Total change in length is zero because the ends are fixed which will not allow the sections to expand or shrink. Load or stress is produced by expansion or shrinkage of the section is taken by the ends. Therefore ends carry some load or stress.

Using principle of superposition the reactions at the end of each section is found from free body diagram. Equate the direction of force in free body diagram to force applied for each section,

A

$$P_{AB} - P_{BC} = P_1$$

$$P_{BC} + P_{CD} = P_2 \text{ Equations } - (A)$$

The equation shows that the section AB and BC is under tension and CD under compression. The direction of load in each section can be chosen as we desire, but if the final result is negative then the direction chosen is incorrect but the answer is correct. So in other words tensile force is actually a compressive force vice versa.

Sum of change in length of each section due to expansion is equal to sum of change in length of each section due to compression. The load P, length L, Area A, and Young's modulus E parameters may vary from section to section.

$$\text{Expansion section} = \text{Compression section}$$

$$\delta_1 + \delta_2 + \dots + \delta_n = \delta_3 + \delta_4 + \dots + \delta_n \text{ Equations } - (B)$$

Using equation A and B the problem can be solved.

### Composite Material of Equal length

Reinforced Columns, Supporting load, Suspended load, Composite structure of equal length (example pipe inside a pipe) these problems can be solved with the following expression.

The change length is same for all materials in that structure. Example in reinforced concrete column (RCC), steel and concrete length change equally, similarly for supporting load, suspended load, and composite structure of equal length. Therefore to solve these problems use the following expressions.

$$\text{Change in length of concrete} = \text{change in length of steel } \delta_{lc} = \delta_{ls} \text{ Equation } - (A)$$

It is same as equation below for equal length only

$$\frac{\zeta_c}{E_c} = \frac{\zeta_s}{E_s}$$

For unequal length it is

$$\frac{\zeta_c L_c}{E_c} = \frac{\zeta_s L_s}{E_s}$$

The load P may be shared by two material equally or unequally.

$$P = P_c + P_s \text{ P is Total load, } P_c \text{ load taken by concrete and } P_s \text{ steel. Or } P = A_c \zeta_c + A_s \zeta_s (B)$$

When the lengths of the composite material are equal by substituting B in A, find the stresses in the materials.

The ratio of  $E_s / E_c$  is known as modular ratio

### Composite Material of Unequal length tubular section

1. Find the material or section whose length is shorter or longer than other material.
1. Calculate the load required to make the section of equal length using formula of  $\delta l$ .
2. This will give the remaining load that will be shared by both the sections.
3. At this point onwards it is similar to composite material of equal length.

### Bolt and Nut:

Load in bolt = Load in tube

$$\zeta_b A_b = \zeta_t A_t$$

Change in length is sum of change in length in bolt and change in length in tube.

$$\delta = \delta_b + \delta_t$$

### Thermal Stresses:

$$\frac{\delta l}{l} = \alpha \Delta t \quad \text{Equation (C)}$$

When there is increase in temperature the material expands this will produce stress. This is known as thermal stress.

$$\delta l = L \alpha \Delta t$$

Thermal stresses when the material is not allowed to expand:

$$\epsilon = \frac{\delta l}{L} = \alpha \Delta t \quad \text{Equation (A)}$$

$$\zeta = E \epsilon \quad \text{Equation (B)}$$

Substituting A in B

$$\zeta = E \alpha \Delta t$$

Thermal stresses when the material is allowed to expand to a length  $\Delta$ :

$$\delta l = l \alpha \Delta t$$

$$\epsilon =$$

Therefore stress is  $\zeta = E \epsilon$ .

### Thermal Stresses in composite bars:

Therefore load in brass is equal to load in steel because temperature is assumed to be uniform.

$$\zeta_s A_s = \zeta_b A_b \quad \text{(A)}$$

Change lengths are therefore strains are equal thus,

$$\frac{\alpha_b t - \zeta_b}{E_b} = \frac{\alpha_s t + \zeta_s}{E_s} \quad \text{-----Equation}$$

Substituting equation A in B to find the stresses in the material.

When the thermal coefficient of one material is larger than the other then that material will be under compression and the other material will be under tension. Thus brass is under compression and steel is under tension in our example.

### Volumetric Strain:

Change in volume to the original volume is known as volumetric strain.

**Poisson ratio:** It is the ratio of lateral strain to the linear strain. It is denoted by symbol  $\mu$

$$\mu = \frac{\text{lateral strain}}{\text{linear strain}} \quad \text{or} \quad m = \frac{1}{\mu}$$

**Change in volume due to axial load in all three directions for a cube or cuboids**

$$\frac{\delta v}{V} = \frac{1}{E} (\zeta_x + \zeta_y + \zeta_z)(1 - 2\mu)$$

This equation is valid only when all the loads are applied as tensile load. The same equation can be used for the following loads,

1. Compressive load change to minus sign to that direction only for the above formula.
2. Load only in one direction the remaining stresses are zero.
3. Load in two directions the remaining stress is zero.

**Change in volume due to axial load for a cylindrical rod**

Change in diameter in cylinder is  $\epsilon_c = \delta d/d$

Change in length in cylinder is  $\epsilon_l = \delta l/l$

Therefore change in volume of cylindrical rod;

$$\frac{\delta v}{V} = \epsilon_l - 2\epsilon_c \quad (\text{Minus sign lateral strain are compressive forces}) \quad \text{OR}$$

$$\frac{\delta v}{V} = \frac{1}{E} (\zeta_x)(1 - 2\mu) \quad \text{Where, } \zeta_y \text{ and } \zeta_z \text{ are zero because load in one direction only.}$$

### Three important moduli's are Elasticity, Bulk, and Rigidity

**Modulus of Elasticity**



**Modulus of Rigidity: Shear stress is proportional to shear strain**

**Strain Energy in Sudden Load**

The stress due to sudden load is found by equating the equation (A) in the following equation.

**Strain Energy in Impact Load**

$$U = \text{Load} \times (\text{height} + \text{Change in length})$$

$$1 + \sqrt{1 + 2Eh(PL)}$$

The stress  $\zeta$  due to impact load when  $\delta L$  is negligible

$$\zeta = \frac{\sqrt{2EPh}}{AL}$$

The stress  $\zeta$  due to impact load when  $\delta L$  is not negligible

$$\zeta = \frac{P}{A}$$

Strain energy due to impact load is found by substituting the stress  $\zeta$  due to impact load in the following equation.

$$U = \frac{\zeta^2}{2E}$$

Problem

*Find the modulus of elasticity for a rod, which tapers uniformly from 30 mm to 15 mm diameter in a length of 350 mm. The rod is subjected to an axial load of 5.5 kN and extension of the rod is 0.025 mm.*

**Sol. Given :**

- Larger diameter,  $D_1 = 30 \text{ mm}$
- Smaller diameter,  $D_2 = 15 \text{ mm}$
- Length of rod,  $L = 350 \text{ mm}$
- Axial load,  $P = 5.5 \text{ kN} = 5500 \text{ N}$
- Extension,  $dL = 0.025 \text{ mm}$

Using equation (1.10), we get

$$dL = \frac{4PL}{\pi E D_1 D_2}$$

or

$$E = \frac{4PL}{\pi D_1 D_2 dL} = \frac{4 \times 5000 \times 350}{\pi \times 30 \times 15 \times 0.025} = 217865 \text{ N/mm}^2 \text{ or } 2.17865 \times 10^5 \text{ N/mm}^2. \text{ Ans.}$$

### **Strain:**

When a single force or a system force acts on a body, it undergoes some deformation. This

deformation per unit length is known as strain. Mathematically strain may be defined as deformation

per unit length.

So,

Strain = Elongation / Original length

### **Elasticity:**

The property of material by virtue of which it returns to its original shape and size upon removal of load is known as elasticity.

### **Hooke's Law**

It states that within elastic limit stress is proportional to strain. Mathematically

$E = \frac{\text{Stress}}{\text{Strain}}$

Where E = Young's Modulus

Hooke's law holds good equally for tension and compression.

### **Poisson's Ratio:**

The ratio lateral strain to longitudinal strain produced by a single stress is known as Poisson's ratio.

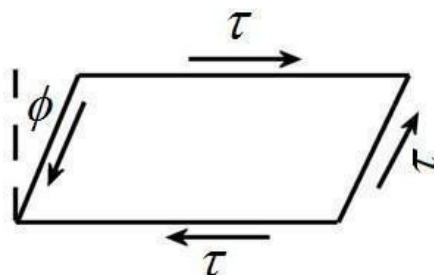
Symbol used for Poisson's ratio is  $\nu$  or  $1/m$ .

### **Modulus of Elasticity (or Young's Modulus)**

Young's modulus is defined as the ratio of stress to strain within elastic limit.

### **Shear Strain**

The distortion produced by shear stress on an element or rectangular block is shown in the figure. The shear strain or „slide“ is expressed by angle  $\phi$  and it can be defined as the change in the right angle. It is measured in radians and is dimensionless in nature.



## Modulus of Rigidity

For elastic materials it is found that shear stress is proportional to the shear strain within elastic limit.

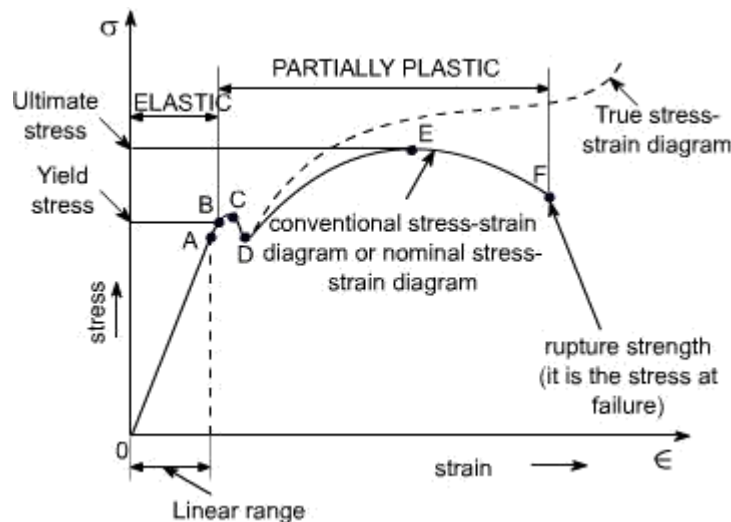
The ratio is called modulus rigidity. It is denoted by the symbol „G“ or „C“.

**Bulk modulus (K):** It is defined as the ratio of uniform stress intensity to the volumetric strain.

It is denoted by the symbol K.

## Relation between elastic constants:

**Elastic constants:** These are the relations which determine the deformations produced by a given stress system acting on a particular material. These factors are constant within elastic limit, and known as modulus of elasticity  $E$ , modulus of rigidity  $G$ , Bulk modulus  $K$  and Poisson's ratio  $\mu$ .



Relationship between modulus of elasticity (E) and bulk modulus (K):

Relationship between modulus of elasticity (E) and modulus of rigidity (G):

## Stress – strain diagram for mild steel

A typical tensile test curve for the mild steel has been shown below

### **SALIENT POINTS OF THE GRAPH:**

(A) So it is evident from the graph that the strain is proportional to strain or elongation is proportional to the load giving a st. line relationship. This law of proportionality is valid upto a point A.

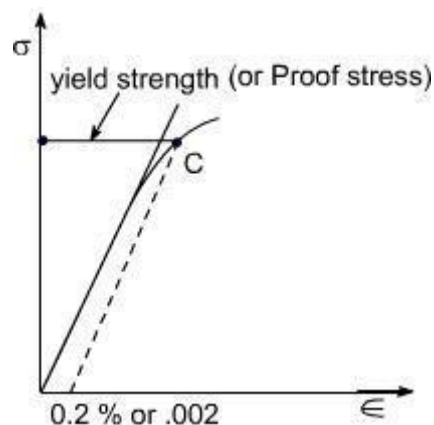
or we can say that point A is some ultimate point when the linear nature of the graph ceases or there is a deviation from the linear nature. This point is known as **the limit of proportionality or the proportionality limit**.

(B) For a short period beyond the point A, the material may still be elastic in the sense that the deformations are completely recovered when the load is removed. The limiting point B is termed as **Elastic Limit**.

(C) and (D) - Beyond the elastic limit plastic deformation occurs and strains are not totally recoverable. There will be thus permanent deformation or permanent set when load is removed. These two points are termed as upper and lower yield points respectively. The stress at the yield point is called the yield strength.

A study a stress – strain diagrams shows that the yield point is so near the proportional limit that for most purpose the two may be taken as one. However, it is much easier to locate the former. For material which do not possess a well define yield points, In order to find the yield point or yield strength, an offset method is applied.

In this method a line is drawn parallel to the straight line portion of initial stress diagram by off setting this by an amount equal to 0.2% of the strain as shown as below and this happens especially for the low carbon steel.



(E) A further increase in the load will cause marked deformation in the whole volume of the metal. The maximum load which the specimen can with stand without failure is called the load at the ultimate strength.

The highest point „E' of the diagram corresponds to the ultimate strength of a material.

$s_u$  = Stress which the specimen can with stand without failure & is known as Ultimate Strength or

Tensile Strength.

$s_u$  is equal to load at E divided by the original cross-sectional area of the bar.

(F) Beyond point E, the bar begins to forms neck. The load falling from the maximum until fracture occurs at F. Beyond point E, the cross-sectional area of the specimen begins to reduce rapidly over a relatively small length of bar and the bar is said to form a neck. This necking takes place whilst the load reduces, and fracture of the bar finally occurs at point F.

### **Nominal stress – Strain OR Conventional Stress – Strain diagrams:**

Stresses are usually computed on the basis of the original area of the specimen; such stresses are often referred to as conventional or nominal stresses.

### **True stress – Strain Diagram:**

Since when a material is subjected to a uniaxial load, some contraction or expansion always takes place. Thus, dividing the applied force by the corresponding actual area of the specimen at the same instant gives the so called true stress.

### **Percentage Elongation: 'd':**

The ductility of a material in tension can be characterized by its elongation and by the reduction in area at the cross section where fracture occurs.

It is the ratio of the extension in length of the specimen after fracture to its initial gauge length, expressed in percentage.

$$\delta = \frac{(l_1 - l_g)}{l_g} \times 100$$

$l_1$  = gauge length of specimen after fracture (or the distance between the gage marks at fracture)

$l_g$  = gauge length before fracture (i.e. initial gauge length)

For 50 mm gage length, steel may have a % elongation  $d$  of the order of 10% to 40%.

### **Ductile and Brittle Materials:**

Based on this behaviour, the materials may be classified as ductile or brittle materials

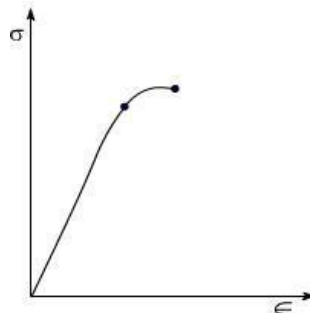
### **Ductile Materials:**

If we just examine the earlier tension curve one can notice that the extension of the materials over the plastic range is considerably in excess of that associated with elastic loading. The capacity of materials to allow these large deformations or large extensions without failure is termed as ductility. The materials with high ductility are termed as ductile materials.

### **Brittle Materials:**

A brittle material is one which exhibits a relatively small extension or deformation to fracture, so that the partially plastic region of the tensile test graph is much reduced.

This type of graph is shown by the cast iron or steels with high carbon contents or concrete.



## **Mechanical Properties of material:**

Elasticity: Property of material by virtue of which it can regain its shape after removal of external load

Plasticity: Property of material by virtue of which, it will be in a state of permanent deformation even after removal of external load.

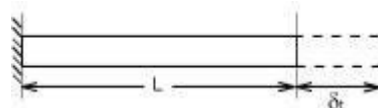
Ductility: Property of material by virtue of which, the material can be drawn into wires.

Hardness: Property of material by virtue of which the material will offer resistance to penetration or indentation

## **Thermal stresses, Bars subjected to tension and Compression**

**Compound bar**: In certain application it is necessary to use a combination of elements or bars made from different materials, each material performing a different function. In overhead electric cables or Transmission Lines for example it is often convenient to carry the current in a set of copper wires surrounding steel wires. The latter being designed to support the weight of the cable over large spans. Such a combination of materials is generally termed compound bars.

**Compound bars subjected to Temp. Change** : Ordinary materials expand when heated and contract when cooled, hence, an increase in temperature produces a positive thermal strain. Thermal strains usually are reversible in a sense that the member returns to its original shape when the temperature returns to its original value. However, there are some materials which do not behave in this manner. These materials differ from ordinary materials in a sense that the strains are related non linearly to temperature and some times are irreversible. When a material is subjected to a change in temp. its length will change by an amount.



$\alpha$  = coefficient of linear expansion for the material  
 $L$  = original Length  
 $t$  = temp. change

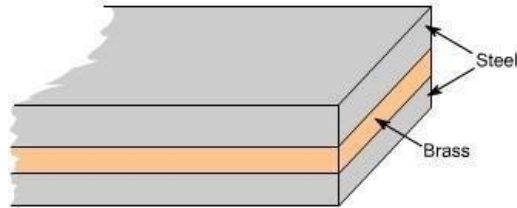
Thus an increase in temperature produces an increase in length and a decrease in temperature results in a decrease in length except in very special cases of materials with zero or negative coefficients of expansion which need not to be considered here.

If however, the free expansion of the material is prevented by some external force, then a stress is set up in the material. This stress is equal in magnitude to that

which would be produced in the bar by initially allowing the bar to its free length and then applying sufficient force to return the bar to its original length.

Consider now a compound bar constructed from two different materials rigidly joined together, for simplicity.

Let us consider that the materials in this case are steel and brass.



If we have both applied stresses and a temp. change, thermal strains may be added to those given by generalized hook's law equation –e.g.

$$\epsilon_x = \frac{1}{E} [\sigma_x - \nu(\sigma_y + \sigma_z)] + \alpha \Delta t$$

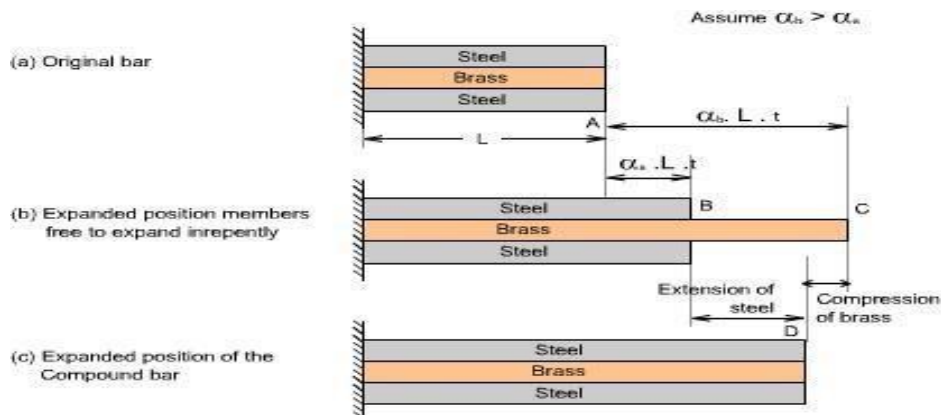
$$\epsilon_y = \frac{1}{E} [\sigma_y - \nu(\sigma_x + \sigma_z)] + \alpha \Delta t$$

$$\epsilon_z = \frac{1}{E} [\sigma_z - \nu(\sigma_x + \sigma_y)] + \alpha \Delta t$$

While the normal strains a body are affected by changes in temperatures, shear strains are not. Because if the temp. of any block or element changes, then its size changes not its shape therefore shear strains do not change.

In general, the coefficients of expansion of the two materials forming the compound bar will be different so that as the temp. rises each material will attempt to expand by different amounts. Figure below shows the positions to which the

individual materials will expand if they are completely free to expand (i.e not joined rigidly together as a compound bar). The extension of any Length  $L$  is given by  $L t$



In general, changes in lengths due to thermal strains may be calculated from equation  $\Delta L = L\alpha\Delta T$ , provided that the members are able to expand or contract freely, □ □

a situation that exists in statically determinate structures. As a consequence no stresses are generated in a statically determinate structure when one or more members undergo a uniform temperature change. If in a structure (or a compound bar), the free expansion or contraction is not allowed then the member becomes statically indeterminate, which is just being discussed as an example of the compound bar and thermal stresses would be generated.

If the two materials are now rigidly joined as a compound bar and subjected to the same temp. rise, each material will attempt to expand to its free length position but each will be affected by the movement of the other. The higher coefficient of expansion material (brass)

**Problem 1** Find the modulus of elasticity for a rod, which tapers uniformly from 30 mm to 15 mm diameter in a length of 350 mm. The rod is subjected to an axial load of 5.5 kN and extension of the rod is 0.025 mm.

**Problem 1** Find the modulus of elasticity for a rod, which tapers uniformly from 30 mm to 15 mm diameter in a length of 350 mm. The rod is subjected to an axial load of 5.5 kN and extension of the rod is 0.025 mm.

**Sol. Given :**

Large diameter,	$D_1 = 30 \text{ mm}$
Smaller diameter,	$D_2 = 15 \text{ mm}$
Length of rod,	$L = 350 \text{ mm}$
Axial load,	$P = 5.5 \text{ kN} = 5500 \text{ N}$
Extension,	$dL = 0.025 \text{ mm}$

Using equation (1.10), we get

$$dL = \frac{APL}{\pi E D_1 D_2}$$

or

$$E = \frac{APL}{\pi D_1 D_2 dL} = \frac{4 \times 5500 \times 350}{\pi \times 30 \times 15 \times 0.025}$$

$= 217865 \text{ N/mm}^2$  or  $2.17865 \times 10^5 \text{ N/mm}^2$ . Ans.

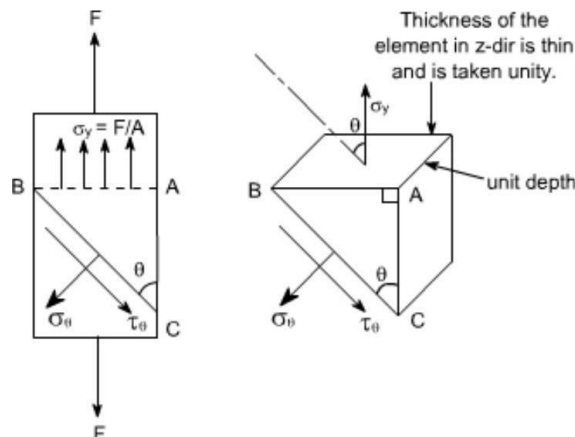
$$\tau_\theta = \frac{\sigma_y}{2} \sin 2\theta \quad (2)$$

If  $\theta = 90^\circ$  the BC will be parallel to AB and  $\tau_\theta = 0$ , i.e. there will be only direct stress or normal stress.

**Stresses on oblique plane:** Till now we have dealt with either pure normal direct stress or pure shear stress. In many instances, however both direct and shear stresses acts and the resultant stress across any section will be neither normal nor tangential to the plane. A plane state of stress is a 2 dimensional state of stress in a sense that the stress components in one direction are all zero i.e

$$\sigma_z = \tau_{yz} = \tau_{zx} = 0$$

Examples of plane state of stress include plates and shells. Consider the general case of a bar under direct load F giving rise to a stress  $\sigma_y$  vertically

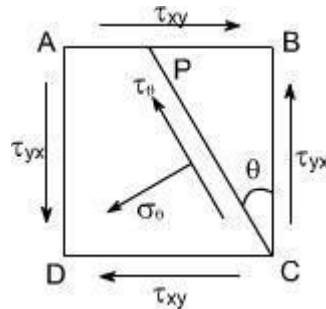




The stress acting at a point is represented by the stresses acting on the faces of the element enclosing the point. The stresses change with the inclination of the planes passing through that point i.e. the stress on the faces of the element vary as the angular position of the element changes. Let the block be of unit depth now considering the equilibrium of forces on the triangle portion ABC. Resolving forces perpendicular to BC.

**Material subjected to pure shear**  $\tau_{xy} = \tau_{yx}$   $\sigma_{\theta} = \tau_{xy} \sin 2\theta$   $\sigma_{\theta} = \tau_{xy} \sin 2\theta$

Consider the element shown to which shear stresses have been applied to the sides AB and DC



Complementary shear stresses of equal value but of opposite effect are then set up on the sides AD and BC in order to prevent the rotation of the element. Since the applied and complementary shear stresses are of equal value on the x and y planes. Now consider the equilibrium of portion of PBC

Assuming unit depth and resolving normal to PC or in the direction of  $\sigma_{\theta}$

$$\sigma_{\theta} \cdot PC \cdot 1 = \tau_{xy} \cdot PB \cdot \cos \theta + \tau_{yx} \cdot BC \cdot \sin \theta \cdot 1$$

$$= \tau_{xy} \cdot PB \cdot \cos \theta + \tau_{yx} \cdot BC \cdot \sin \theta$$

Now writing PB and BC in terms of PC so that it cancels out from the two sides

$$PB/PC = \sin \theta \quad BC/PC = \cos \theta$$

$$\sigma_{\theta} \cdot PC \cdot 1 = \tau_{xy} \cdot \cos \theta \sin \theta PC + \tau_{yx} \cdot \cos \theta \cdot \sin \theta \cdot PC$$

$$\sigma_{\theta} = 2 \tau_{xy} \sin \theta \cos \theta$$

Or,  $\sigma_{\theta} = 2 \tau_{xy} \sin 2\theta$  (1)

Now resolving forces parallel to PC or in the direction of  $\sigma_{\theta}$  .then  $\tau_{xy} \cdot PC \cdot 1$

$$= \tau_{xy} \cdot PB \sin \theta - \tau_{yx} \cdot BC \cos \theta$$

-ve sign has been put because this component is in the same direction as that of  $\tau_{\theta}$  .

again converting the various quantities in terms of PC we have

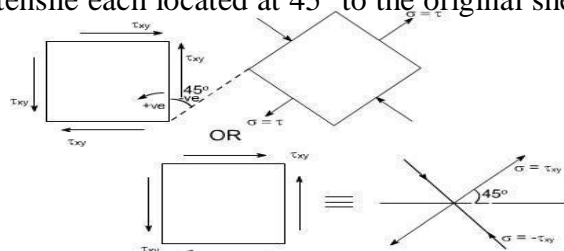
$$\tau_{xy} \cdot PC \cdot 1 = \tau_{xy} \cdot PB \cdot \sin^2 \theta - \tau_{yx} \cdot PC \cos^2 \theta$$

$$= -\tau_{xy} [\cos^2 \theta - \sin^2 \theta]$$

$$= -\tau_{xy} \cos 2\theta$$
 (2)

values of  $\sigma_{\theta} > 0$  (tension) and  $\sigma_{\theta} < 0$  (compression) on plane at  $\pm 45^\circ$  to the applied shear and on these planes the tangential component  $\tau_{\theta}$  is zero.

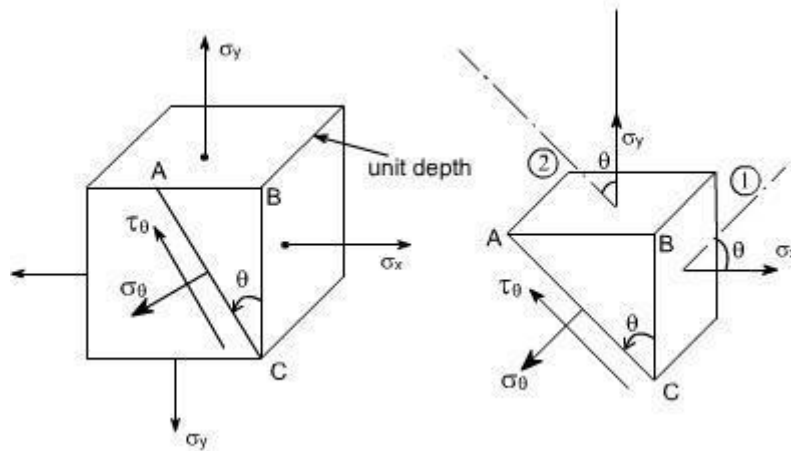
Hence the system of pure shear stresses produces an equivalent direct stress system, one set compressive and one tensile each located at  $45^\circ$  to the original shear directions as depicted in the figure below:



$$\sigma_{\theta} = \left( \frac{\sigma_x + \sigma_y}{2} \right) + \left( \frac{\sigma_x - \sigma_y}{2} \right) \cos 2\theta$$

**Material subjected to two mutually perpendicular direct stresses:**

Now consider a rectangular element of unit depth, subjected to a system of two direct stresses both tensile,  $\sigma_x$  and  $\sigma_y$  acting right angles to each other.



(3)

Now resolving parallel to AC

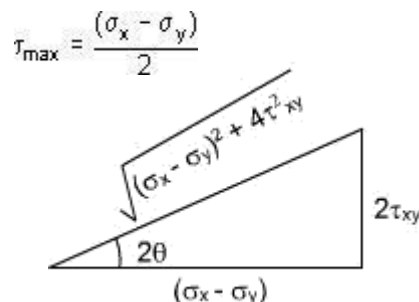
$$\sigma_{AC} \cdot AC \cdot 1 = \sigma_x \cdot AB \cdot 1 + \sigma_y \cdot BC \cdot 1$$

The -ve sign appears because this component is in the same direction as that of AC. Again converting the various quantities in terms of AC so that the AC cancels out from the two sides.

**Conclusions :**

The following conclusions may be drawn from equation (3) and (4)

- (i) The maximum direct stress would be equal to  $\sigma_x$  or  $\sigma_y$  whichever ever is the greater, when  $\theta = 0^\circ$  or  $90^\circ$
- (ii) The maximum shear stress in the plane of the applied stresses occurs when  $\theta = 45^\circ$

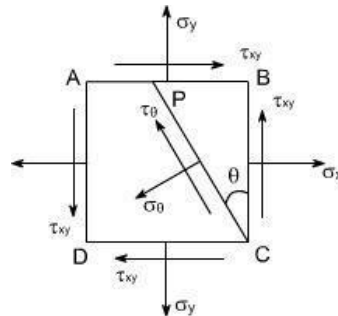


**Material subjected to combined direct and shear stresses:**

Now consider a complex stress system shown below, acting on an element of material.

The stresses  $\sigma_x$  and  $\sigma_y$  may be compressive or tensile and may be the result of direct forces or as a result of bending. The shear stresses may be as shown or completely reversed and occur as a result of either shear force or torsion as shown in the figure below:

As per the double subscript notation the shear stress on the face BC should be notified as  $\tau_{yx}$ , however, we have already seen that for a pair of shear stresses there is a set of complementary shear



stresses generated such that  $\tau_{yx} = \tau_{xy}$

By looking at this state of stress, it may be observed that this state of stress is combination of two different cases:

(i) Material subjected to two mutually perpendicular direct stresses. In this case the various formula's derived are as follows.

To get the required equations for the case under consideration, let us add the respective equations for the above two cases such that

These are the equilibrium equations for stresses at a point. They do not depend on material proportions and are equally valid for elastic and inelastic behavior

This eqn gives two values of  $2\theta$  that differ by  $180^\circ$ . Hence the planes on which maximum and minimum normal stresses accurate  $90^\circ$  apart.

For  $\sigma_\theta$  to be a maximum or minimum  $\frac{d\sigma_\theta}{d\theta} = 0$

Now

$$\sigma_\theta = \frac{(\sigma_x + \sigma_y)}{2} + \frac{(\sigma_x - \sigma_y)}{2} \cos 2\theta + \tau_{xy} \sin 2\theta$$

$$\frac{d\sigma_\theta}{d\theta} = -\frac{1}{2}(\sigma_x - \sigma_y) \sin 2\theta + \tau_{xy} \cos 2\theta = 0$$

i.e.  $-(\sigma_x - \sigma_y) \sin 2\theta + \tau_{xy} \cos 2\theta = 0$

$$\tau_{xy} \cos 2\theta = (\sigma_x - \sigma_y) \sin 2\theta$$

Thus,  $\tan 2\theta = \frac{2\tau_{xy}}{(\sigma_x - \sigma_y)}$

From the triangle it may be determined

Substituting the values of  $\cos 2\theta$  and  $\sin 2\theta$  in equation (5) we get

$$\cos 2\theta = \frac{(\sigma_x - \sigma_y)}{\sqrt{(\sigma_x - \sigma_y)^2 + 4\tau_{xy}^2}}$$

$$\sin 2\theta = \frac{2\tau_{xy}}{\sqrt{(\sigma_x - \sigma_y)^2 + 4\tau_{xy}^2}}$$

$$\begin{aligned} \sigma_\theta &= \frac{(\sigma_x + \sigma_y)}{2} + \frac{(\sigma_x - \sigma_y)}{2} \cos 2\theta + \tau_{xy} \sin 2\theta \\ \sigma_\theta &= \frac{(\sigma_x + \sigma_y)}{2} + \frac{(\sigma_x - \sigma_y)}{2} \cdot \frac{(\sigma_x - \sigma_y)}{\sqrt{(\sigma_x - \sigma_y)^2 + 4\tau_{xy}^2}} \\ &\quad + \frac{\tau_{xy} \cdot 2\tau_{xy}}{\sqrt{(\sigma_x - \sigma_y)^2 + 4\tau_{xy}^2}} \\ &= \frac{(\sigma_x + \sigma_y)}{2} + \frac{1}{2} \cdot \frac{(\sigma_x - \sigma_y)^2}{\sqrt{(\sigma_x - \sigma_y)^2 + 4\tau_{xy}^2}} \\ &\quad + \frac{1}{2} \cdot \frac{4\tau_{xy}^2}{\sqrt{(\sigma_x - \sigma_y)^2 + 4\tau_{xy}^2}} \end{aligned}$$

or

$$\begin{aligned} &= \frac{(\sigma_x + \sigma_y)}{2} + \frac{1}{2} \cdot \frac{(\sigma_x - \sigma_y)^2 + 4\tau_{xy}^2}{\sqrt{(\sigma_x - \sigma_y)^2 + 4\tau_{xy}^2}} \\ &= \frac{1}{2}(\sigma_x + \sigma_y) \pm \frac{1}{2} \cdot \frac{\sqrt{(\sigma_x - \sigma_y)^2 + 4\tau_{xy}^2} \cdot \sqrt{(\sigma_x - \sigma_y)^2 + 4\tau_{xy}^2}}{\sqrt{(\sigma_x - \sigma_y)^2 + 4\tau_{xy}^2}} \end{aligned}$$

$$\sigma_\theta = \frac{1}{2}(\sigma_x + \sigma_y) \pm \frac{1}{2} \sqrt{(\sigma_x - \sigma_y)^2 + 4\tau_{xy}^2}$$

Hence we get the two values of  $\sigma_\theta$ , which are designated  $\sigma_1$  as  $\sigma_2$  and respectively, therefore

$$\sigma_1 = \frac{1}{2}(\sigma_x + \sigma_y) + \frac{1}{2} \sqrt{(\sigma_x - \sigma_y)^2 + 4\tau_{xy}^2}$$

$$\sigma_2 = \frac{1}{2}(\sigma_x + \sigma_y) - \frac{1}{2} \sqrt{(\sigma_x - \sigma_y)^2 + 4\tau_{xy}^2}$$

The  $\sigma_1$  and  $\sigma_2$  are termed as the principle stresses of the system.

Substituting the values of  $\cos 2\theta$  and  $\sin 2\theta$  in equation (6) we see that

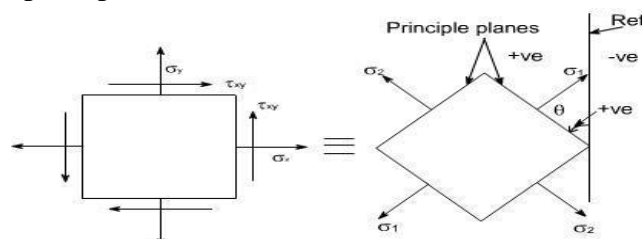
$$\begin{aligned} \tau_\theta &= \frac{1}{2}(\sigma_x - \sigma_y) \sin 2\theta - \tau_{xy} \cos 2\theta \\ &= \frac{1}{2}(\sigma_x - \sigma_y) \cdot \frac{2\tau_{xy}}{\sqrt{(\sigma_x - \sigma_y)^2 + 4\tau_{xy}^2}} - \frac{\tau_{xy} \cdot (\sigma_x - \sigma_y)}{\sqrt{(\sigma_x - \sigma_y)^2 + 4\tau_{xy}^2}} \end{aligned}$$

$$\tau_\theta = 0$$

This shows that the values shear stress is zero on the principal planes.

Once the maximum and minimum values of normal stresses occur on planes of zero shearing stress. The maximum and minimum normal stresses are called the principal stresses, and the planes on which they act are called principal plane the solution of equation ill yield two values of  $2\theta$  separated by  $180^\circ$  i.e. two values of  $\theta$  separated by  $90^\circ$ . Thus the two principal stresses occur on mutually perpendicular planes termed principal planes.

Therefore the two – dimensional complex stress system can now be reduced to the equivalent system of principal stresses.



Let us recall that for the case of a material subjected to direct stresses the value of maximum shear stresses

$$\tau_{\max} = \frac{1}{2}(\sigma_x - \sigma_y) \text{ at } \theta = 45^\circ, \text{ Thus, for a 2-dimensional state of stress, subjected to principle stresses}$$

$$\tau_{\max} = \frac{1}{2}(\sigma_1 - \sigma_2), \text{ on substituting the values of } \sigma_1 \text{ and } \sigma_2, \text{ we get}$$

$$\tau_{\max} = \frac{1}{2} \sqrt{(\sigma_x - \sigma_y)^2 + 4\tau_{xy}^2}$$

Alternatively this expression can also be obtained by differentiating the expression for  $\tau_\theta$  with respect to  $\theta$  i.e.

$$\tau_\theta = \frac{(\sigma_x - \sigma_y)}{2} \sin 2\theta - \tau_{xy} \cos 2\theta$$

$$\frac{d\tau_\theta}{d\theta} = -\frac{1}{2}(\sigma_x - \sigma_y) \cos 2\theta + 2\tau_{xy} \sin 2\theta = 0$$

$$\text{or } (\sigma_x - \sigma_y) \cos 2\theta + 2\tau_{xy} \sin 2\theta = 0$$

$$\tan 2\theta_s = \frac{(\sigma_y - \sigma_x)}{2\tau_{xy}} = -\frac{(\sigma_x - \sigma_y)}{2\tau_{xy}}$$

$$\tan 2\theta_s = -\frac{(\sigma_x - \sigma_y)}{2\tau_{xy}}$$

Recalling that

$$\tan 2\theta_p = \frac{2\tau_{xy}}{(\sigma_x - \sigma_y)}$$

Thus,

$$\boxed{\tan 2\theta_p \cdot \tan 2\theta_s = 1}$$

Therefore, it can be concluded that the equation (2) is a negative reciprocal of equation (1) hence the roots for the double angle of equation (2) are  $90^\circ$  away from the corresponding angle of equation (1).

This means that the angles that locate the plane of maximum or minimum shearing stresses form angles of  $45^\circ$  with the planes of principal stresses.

Further, by making the triangle we get

$$\cos 2\theta = \frac{2\tau_{xy}}{\sqrt{(\sigma_y - \sigma_x)^2 + 4\tau_{xy}^2}}$$

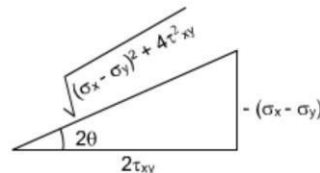
$$\sin 2\theta = \frac{-(\sigma_x - \sigma_y)}{\sqrt{(\sigma_y - \sigma_x)^2 + 4\tau_{xy}^2}}$$

Therefore by substituting the values of  $\cos 2\theta$  and  $\sin 2\theta$  we have

$$\begin{aligned} \tau_\theta &= \frac{1}{2}(\sigma_x - \sigma_y) \sin 2\theta - \tau_{xy} \cos 2\theta \\ &= \frac{1}{2} \cdot \frac{(\sigma_x - \sigma_y) \cdot (\sigma_x - \sigma_y)}{\sqrt{(\sigma_y - \sigma_x)^2 + 4\tau_{xy}^2}} - \frac{\tau_{xy} \cdot 2\tau_{xy}}{\sqrt{(\sigma_y - \sigma_x)^2 + 4\tau_{xy}^2}} \end{aligned}$$

$$= -\frac{1}{2} \frac{(\sigma_y - \sigma_x)^2 + 4\tau_{xy}^2}{\sqrt{(\sigma_y - \sigma_x)^2 + 4\tau_{xy}^2}}$$

$$\tau_\theta = \pm \frac{1}{2} \sqrt{(\sigma_x - \sigma_y)^2 + 4\tau_{xy}^2}$$



$$\sigma_{\theta} = \frac{(\sigma_x + \sigma_y)}{2} + \frac{(\sigma_x - \sigma_y)}{2} \cos 2\theta + \tau_{xy} \sin 2\theta$$

Because of the difference in sign convention arises from the point of view of locating the planes on which shear stress act. From physical point of view these sign have no meaning.

The largest stress regard less of sign is always know as maximum shear stress.

### Principal plane inclination in terms of associated principal stress:

$$\tan 2\theta_p = \frac{2\tau_{xy}}{(\sigma_x - \sigma_y)}$$

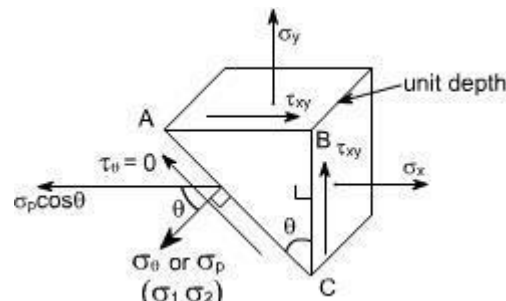
We know that the equation

yields two values of  $\theta$  i.e. the inclination of the two principal planes on which the principal stresses  $s_1$  and  $s_2$  act. It is uncertain, however, which stress acts on which plane unless equation. is used and observing which one of the

two principal stresses is obtained.

Alternatively we can also find the answer to this problem in the following manner

Consider once again the equilibrium of a triangular block of material of unit depth, Assuming



AC to be a principal plane on which principal stresses  $\sigma_p$  acts, and the shear stress is zero.

Resolving the forces horizontally we get:

$\sigma_x \cdot BC \cdot 1 + \tau_{xy} \cdot AB \cdot 1 = \sigma_p \cdot \cos\theta \cdot AC$  dividing the above equation through by BC we get

$$\sigma_x + \tau_{xy} \frac{AB}{BC} = \sigma_p \cdot \cos\theta \cdot \frac{AC}{BC}$$

or

$$\sigma_x + \tau_{xy} \tan\theta = \sigma_p$$

Thus

$$\tan\theta = \frac{\sigma_p - \sigma_x}{\tau_{xy}}$$

### GRAPHICAL SOLUTION – MOHR'S STRESS CIRCLE

The transformation equations for plane stress can be represented in a graphical form known as Mohr's circle. This graphical representation is very useful in depicting the relationships between normal and shear stresses acting on any inclined plane at a point in a stressed body.

To draw a Mohr's stress circle consider a complex stress system as shown in the figure

The above system represents a complete stress system for any condition of applied load in two dimensions

The Mohr's stress circle is used to find out graphically the direct stress  $\sigma$  and shear stress  $\tau$  on any plane inclined at  $\theta$  to the plane on which  $\sigma_x$  acts. The direction of  $\tau$  here is taken in anticlockwise direction from the BC.

**STEPS:**

In order to do achieve the desired objective we proceed in the following manner

- (i) Label the Block ABCD.
- (ii) Set up axes for the direct stress (as abscissa) and shear stress (as ordinate)
- (iii) Plot the stresses on two adjacent faces e.g. AB and BC, using the following sign convention.

Direct stresses  $\ll$  tensile positive; compressive, negative  
 Shear stresses – tending to turn block clockwise, positive  
 – tending to turn block counter clockwise, negative

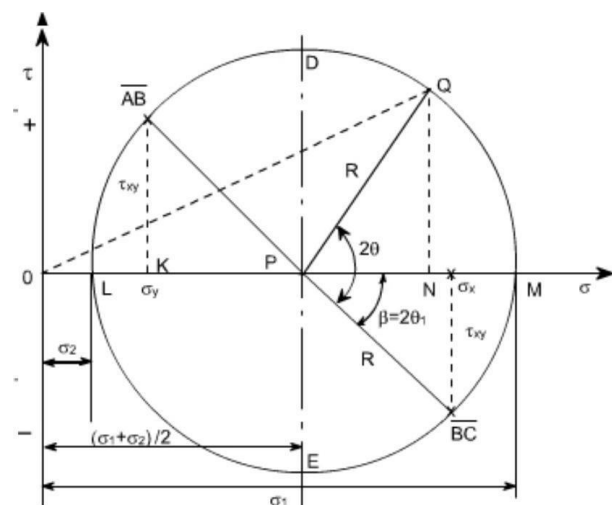
[ i.e shearing stresses are +ve when its movement about the centre of the element is clockwise ]

This gives two points on the graph which may than be labeled as respectively to denote stresses on these planes.

- (iv) Join  $\overline{AB}$  and  $\overline{BC}$  .
- (v) The point P where this line cuts the s axis is than the centre of Mohr's stress circle and the line joining  $\overline{AB}$  and  $\overline{BC}$  is diameter. Therefore the circle can now be drawn.

Now every point on the circle then represents a state of stress on some plane through C.

**Proof:**



Consider any point Q on the circumference of the circle, such that PQ makes an angle  $2\alpha$  with BC, and drop a perpendicular from Q to meet the  $\sigma$  axis at N. Then OQ represents the resultant stress on the plane an angle  $\alpha$  to BC. Here we have assumed that  $\alpha_x < \alpha_y$

Now let us find out the coordinates of point Q. These are ON and QN.

From the figure drawn earlier

$$ON = OP + PN$$

$$OP = OK + KP$$

If we examine the equation (1) and (2), we see that this is the same equation which we have already derived analytically

Thus the co-ordinates of Q are the normal and shear stresses on the plane inclined at  $\alpha$  to BC in the original stress system.

**N.B:** Since angle  $\overline{PQ}$  is  $2\alpha$  on Mohr's circle and not  $\alpha$  it becomes obvious that angles are doubled on Mohr's circle. This is the only difference, however, as they are measured in the same direction and from the same plane in both figures.

Further points to be noted are

(1) The direct stress is maximum when Q is at M and at this point obviously the shear stress is zero, hence by definition OM is the length representing the maximum principal stresses  $\alpha_1$  and  $2\alpha_1$  gives the angle of the plane  $\alpha_1$  from BC. Similar OL is the other principal stress and is represented by  $\alpha_2$

(2) The maximum shear stress is given by the highest point on the circle and is represented by the radius of the circle.

This follows that since shear stresses and complimentary shear stresses have the same value; therefore the centre of the circle will always lie on the  $\sigma$  axis midway between  $\alpha_x$  and  $\alpha_y$ . [ since  $+\alpha_{xy}$  &  $-\alpha_{xy}$  are shear stress & complimentary shear stress so they are same in magnitude but different in sign. ]

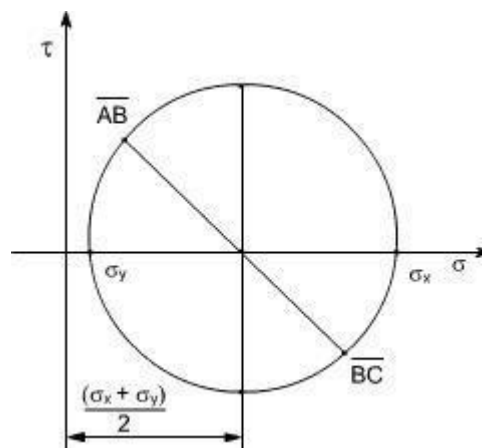
(3) From the above point the maximum shear stress i.e. the Radius of the Mohr's stress circle would be

$$\frac{(\sigma_x - \sigma_y)}{2}$$

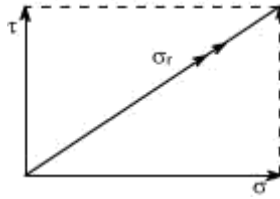
While the direct stress on the plane of maximum shear must be mid – may between  $\alpha_x$  and  $\alpha_y$

i.e

$$\frac{(\sigma_x + \sigma_y)}{2}$$







(4) As already defined the principal planes are the planes on which the shear components are zero.

Therefore we conclude that on principal plane the shear stress is zero.

(5)

(6) Since the resultant of two stresses at  $90^\circ$  can be found from the parallelogram of vectors as shown in the diagram. Thus, the resultant stress on the plane at  $q$  to  $BC$  is given by  $OQ$  on Mohr's Circle.

(6) The graphical method of solution for a complex stress problem using Mohr's circle is a very powerful technique, since all the information relating to any plane within the stressed element is contained in the single construction. It thus, provides a convenient and rapid means of solution. Which is less prone to arithmetical errors and is highly recommended.

### **Numericals:**

Let us discuss few representative problems dealing with complex state of stress to be solved either analytically or graphically.

#### **Q2:**

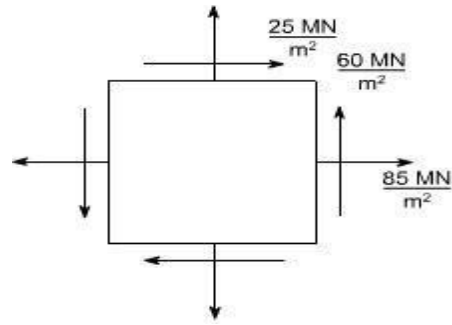
For a given loading conditions the state of stress in the wall of a cylinder is expressed as follows:

- (a)  $85 \text{ MN/m}^2$  tensile
  - (b)  $25 \text{ MN/m}^2$  tensile at right angles to (a)
  - (c) Shear stresses of  $60 \text{ MN/m}^2$  on the planes on which the stresses (a) and (b) act; the shear couple acting on planes carrying the  $25 \text{ MN/m}^2$  stress is clockwise in effect.
- Calculate the principal stresses and the planes on which they act. What would be the effect on these results if owing to a change of loading (a) becomes compressive while stresses (b) and (c) remain unchanged

#### **Solution:**

The problem may be attempted both analytically as well as graphically. Let us first obtain the analytical solution

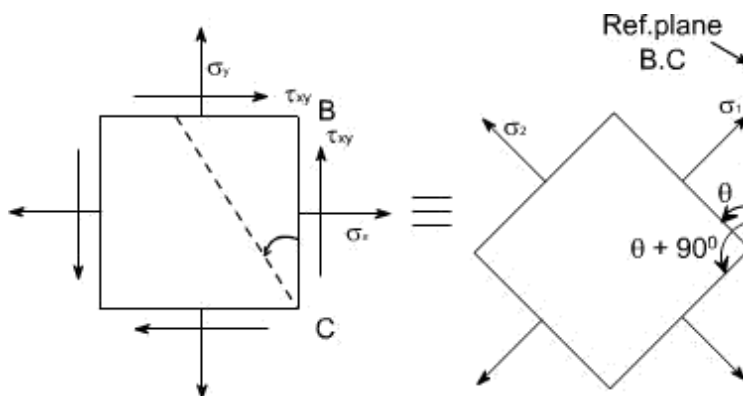
$$\begin{aligned}
 &\sigma_1 \text{ and } \sigma_2 \\
 &= \frac{1}{2}(\sigma_x + \sigma_y) \pm \frac{1}{2}\sqrt{(\sigma_x - \sigma_y)^2 + 4\tau_{xy}^2} \\
 &= \frac{1}{2}(85 + 25) \pm \frac{1}{2}\sqrt{(85 + 25)^2 + (4 \times 60^2)} \\
 &= 55 \pm \frac{1}{2} \cdot 60\sqrt{5} = 55 \pm 67 \\
 &\Rightarrow \sigma_1 = 122 \text{ MN/m}^2 \\
 &\tan 2\theta = \left( \frac{\sigma_2 - \sigma_1}{2\tau_{xy}} \right) = \frac{-122 - (-12)}{2 \times 60} \text{ MN/m}^2 \text{ (compressive)}
 \end{aligned}$$



The principle stresses are given by the formula

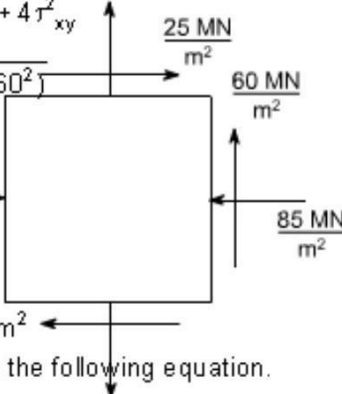
For finding out the planes on which the principle stresses act use the equation

The solution of this equation will yield two values < i.e.  $\tan 2\theta < 1$  and  $\tan 2\theta > 1$  giving  $\theta < 45^\circ$  &  $\theta > 45^\circ$



(b) In this case only the loading (a) is changed i.e. its direction had been changed. While the other stresses remains unchanged hence now the block diagram becomes.

Again the principal stresses would be given by the equation.

$$\begin{aligned} \sigma_1 \& \sigma_2 &= \frac{1}{2}(\sigma_x + \sigma_y) \pm \frac{1}{2}\sqrt{(\sigma_x - \sigma_y)^2 + 4\tau_{xy}^2} \\ &= \frac{1}{2}(-85 + 25) \pm \frac{1}{2}\sqrt{(-85 - 25)^2 + (4 \times 60^2)} \\ &= \frac{1}{2}(-60) \pm \frac{1}{2}\sqrt{(-85 - 25)^2 + (4 \times 60^2)} \\ &= -30 \pm \frac{1}{2}\sqrt{12100 + 14400} \\ &= -30 \pm 81.4 \\ \sigma_1 &= 51.4 \text{ MN/m}^2; \sigma_2 = -111.4 \text{ MN/m}^2 \end{aligned}$$


Again for finding out the angles use the following equation.

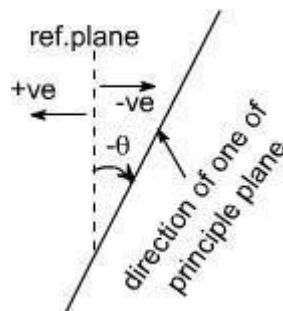
$$\begin{aligned} \tan 2\theta &= \left( \frac{2\tau_{xy}}{\sigma_x - \sigma_y} \right) \\ &= \frac{2 \times 60}{-85 - 25} = + \frac{120}{-110} \\ &= -\frac{12}{11} \\ 2\theta &= \tan^{-1} \left( -\frac{12}{11} \right) \\ \Rightarrow \theta &= -23.74^\circ \end{aligned}$$

Thus, the two principle stresses acting on the two mutually perpendicular planes i.e principle planes may be depicted on the element as shown below:

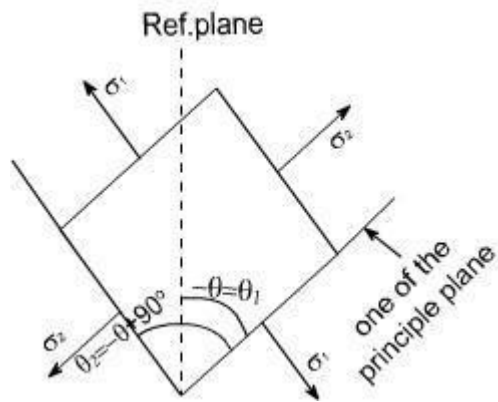
So this is the direction of one principle plane & the principle stresses acting on this would be  $\sigma_1$  when is acting normal to this plane, now the direction of other principal plane would be  $90^\circ + \theta$  because the principal planes are the two mutually perpendicular plane, hence rotate the another plane

$\theta + 90^\circ$  in the same direction to get the another plane, now complete the material element if  $\theta$  is negative that means we are measuring the angles in the opposite direction to the reference plane BC .

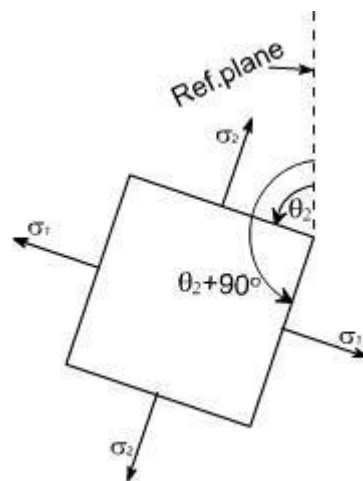
Therefore the direction of other principal planes would be  $\{\theta + 90\}$  since the angle  $\theta$  is always less in magnitude then 90 hence the quantity  $(\theta + 90)$  would be positive therefore the Inclination of other plane with reference plane would be positive therefore if just complete the Block.



It would appear as



If we just want to measure the angles from the reference plane, than rotate this block through  $180^\circ$  so as to have the following appearance.



So whenever one of the angles comes negative to get the positive value, first Add  $90^\circ$  to the value and again add  $90^\circ$  as in this case  $\angle = \angle 23^\circ 74'$  so  $\angle_1 = \angle 23^\circ 74' + 90^\circ = 66^\circ 26'$ . Again adding  $90^\circ$  also gives the direction of other principle

planes

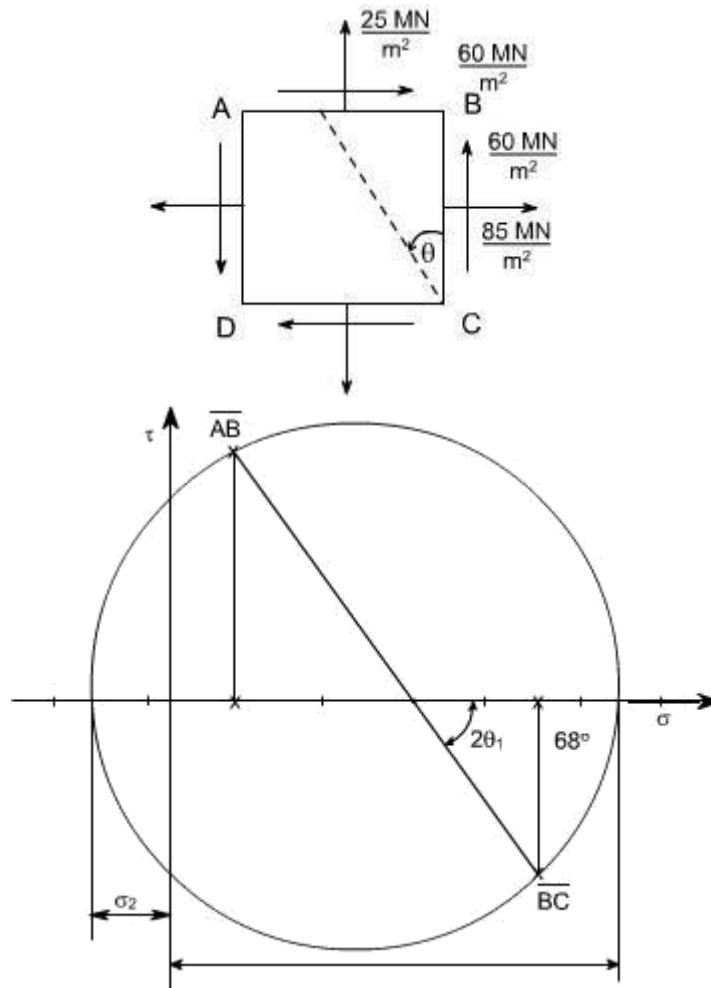
$$\text{i.e } \angle_2 = 66^\circ 26' + 90^\circ = 156^\circ 26'$$

This is how we can show the angular position of these planes clearly.

### **GRAPHICAL SOLUTION:**

**Mohr's Circle solution:** The same solution can be obtained using the graphical solution i.e the Mohr's stress circle, for the first part, the block diagram bec

Construct the graphical construction as per the steps given earlier.



Taking the measurements from the Mohr's stress circle, the various quantities computed are

$$\sigma_1 = 120 \text{ MN/m}^2 \text{ tensile}$$

$$\sigma_2 = 10 \text{ MN/m}^2 \text{ compressive}$$

$$\theta_1 = 34^\circ \text{ counter clockwise from BC}$$

$$\theta_2 = 34^\circ + 90 = 124^\circ \text{ counter clockwise from BC}$$

**Part Second :** The required configuration i.e the block diagram for this case is shown along with the stress circle. By taking the measurements, the various quantities computed are given as

$$\sigma_1 = 56.5 \text{ MN/m}^2 \text{ tensile}$$

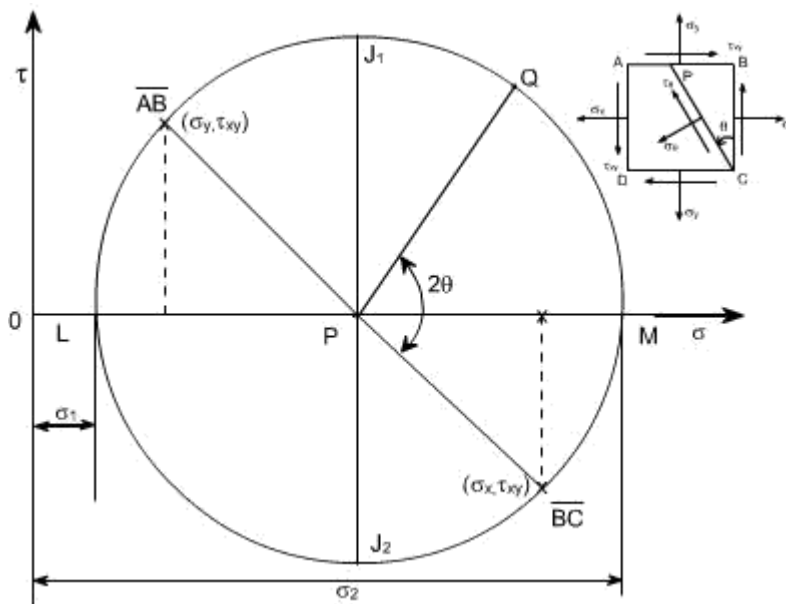
$$\sigma_2 = 106 \text{ MN/m}^2 \text{ compressive}$$

$$\theta_1 = 66^\circ 15' \text{ counter clockwise from BC}$$

$$\theta_2 = 156^\circ 15' \text{ counter clockwise from BC}$$

**Salient points of Mohr's stress circle:**

1. complementary shear stresses (on planes 90° apart on the circle) are equal in magnitude
2. The principal planes are orthogonal: points L and M are 180° apart on the circle (90° apart in material)
3. There are no shear stresses on principal planes: point L and M lie on normal stress axis.
4. The planes of maximum shear are 45° from the principal points D and E are 90°, measured round the circle from points L and M.
5. The maximum shear stresses are equal in magnitude and given by points D and E
6. The normal stresses on the planes of maximum shear stress are equal i.e. points D and E both have normal stress co-ordinate which is equal to the two principal stresses.



know that the circle represents all possible states of normal and shear stress on any plane through a stresses point in a material. Further we have seen that the co-ordinates of the point „Q' are seen to be the same as those derived from equilibrium of the element. i.e. the normal and shear stress components on any plane passing through the point can be found using Mohr's circle. Worthy of note:

1. The sides AB and BC of the element ABCD, which are 90° apart, are represented on the circle by  $\overline{AB} P$  and  $\overline{BC} P$  and they are 180° apart.
2. It has been shown that Mohr's circle represents all possible states at a point. Thus, it can be seen at a point. Thus, it, can be seen that two planes LP and PM, 180° apart on the diagram and therefore 90° apart in the material, on which shear stress < < is zero. These planes are termed as principal planes and normal stresses σ acting on them are known as principal stresses.  
Thus , < 1 = OL  
< 2 = OM
3. The maximum shear stress in an element is given by the top and bottom points of the circle i.e by points J1 and J2 ,Thus the maximum shear stress would be equal to the radius of i.e. < max= 1/2(<< 1 <<< 2 ),the corresponding normal stress is obviously the

distance  $OP = 1/2 (\sigma_x + \sigma_y)$ , Further it can also be seen that the planes on which the shear stress is maximum are situated  $90^\circ$  from the principal planes ( on circle ), and  $45^\circ$  in the material.

4. The minimum normal stress is just as important as the maximum. The algebraic minimum stress could have a magnitude greater than that of the maximum principal stress if the state of stress

were such that the centre of the circle is to the left of

origin. i.e. if  $\sigma_1 = 20 \text{ MN/m}^2$  (say)

$\sigma_2 = -80 \text{ MN/m}^2$  (say)

Then  $\sigma_{max} = (\sigma_1 + \sigma_2 / 2) = 50 \text{ MN/m}^2$

It should be noted that the principal stresses are considered a maximum or minimum mathematically e.g. a compressive or negative stress is less than a positive stress, irrespective of numerical value.

5. Since the stresses on perpendicular faces of any element are given by the co-ordinates of two

diametrically opposite points on the circle, thus, the sum of the two normal stresses for any and all orientations of the element is constant, i.e. This sum is an invariant for any particular state of stress.

Sum of the two normal stress components acting on mutually perpendicular planes at a point in a state of plane stress is not affected by the orientation of these planes.

This can be also understood from the circle Since AB and BC are diametrically opposite thus,

what ever may be their orientation, they will always lie on the diameter or we can say that their sum won't change; it can also be seen from analytical relations

We know 
$$\sigma_n = \frac{(\sigma_x + \sigma_y)}{2} + \frac{(\sigma_x - \sigma_y)}{2} \cos 2\theta + \tau_{xy} \sin 2\theta$$

on plane BC;  $\sigma = 0$

$\sigma_{n1} = \sigma_x$

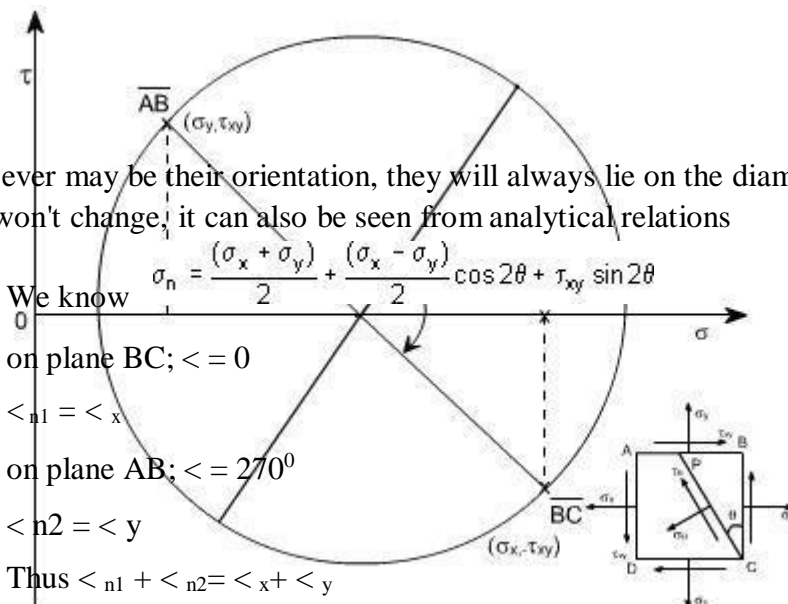
on plane AB;  $\sigma = \sigma_y$

$\sigma_{n2} = \sigma_y$

Thus  $\sigma_{n1} + \sigma_{n2} = \sigma_x + \sigma_y$

6. If  $\sigma_1 = \sigma_2$ , the Mohr's stress circle degenerates into a point and no shearing stresses are developed on xy plane.

7. If  $\sigma_x + \sigma_y = 0$ , then the center of Mohr's circle coincides with the origin of  $\sigma$  co-ordinates.



## SUMMARY

**Principal Plane:** - It is a plane where shear force is zero is called principal plane.

**Principal Stress:** - The normal stress on the principal plane is called principal stress. **Obliquity:** - It is angle between the resultant stress and normal stress.

**Mohr's circle:** - It is a graphical (circle) method to find the stresses and strains on a plane.

### **Principal Plane and Stresses can be solved by**

1. Analytical Method – Solving horizontal and vertical stresses to find the normal stress and shear stress using trigonometry method.
2. Graphical Method – Mohr's circle method

### **Analytical Method:**

The equation is solved assuming  $\zeta_x$  and  $\zeta_y$  as tensile stresses as positive and  $\eta_{xy}$  shear stress clockwise as positive to major principal stress. Simply change the sign if stresses are opposite.

### **Graphical Method - Drawing Rules of Mohr's Circle:**

1. Fix the origin (0,0) that is (x,y) at convenient place in the graph.
2. X –axis to locate axial stress for both x and y directions.
3. Y –axis to locate shear stress for clockwise and anti clockwise shear.
4. Tensile stress is positive along x axis right of origin.
5. Compressive stress is negative along x axis left of origin.
6. Clockwise Shear stress is positive along y axis upward of origin.
7. Anti clockwise shear stress is negative along y axis downward of origin..
8. When there is no shear force ( $\eta_{xy} = 0$ ) draw Mohr's circle from axial stresses. The centre of the Mohr's circle bisects axial stresses ( $\zeta_x, 0$ ) and ( $\zeta_y, 0$ ).
9. When there is shear force draw Mohr's circle from axial stresses and shear stress. The centre of the Mohr's circle bisects the line between ( $\zeta_x, \eta_{xy}$ ) and ( $\zeta_y, \eta_{xy}$ ).
10. Angle of inclination is to be drawn from point ( $\zeta_y, \eta_{xy}$ ) at centre of Mohr's to angle  $2\theta$  in clockwise direction.
11. Normal stress, and maximum and minimum principal stresses are taken from the origin along the x-axis of the Mohr's circle.
12. Maximum shear stress is the radius of the Mohr's circle, and shear stresses are taken along the y-axis of the Mohr's circle.
13. The angle between the resultant stress and normal stress is angle of oblique.



## UNIT 2

### Shear Force and Bending Moment

Any sign convention can be followed but it should be uniform throughout the problem. We have chosen upward load or shear force as positive and downward load or shear force as negative. Similarly take clockwise moment as negative and anticlockwise moment as positive.

#### Cantilever Beam:

1. Simply add the load from right to find the shear force at various points. Upward SF minus downward SF will give SF at a point it may be +ve or –ve SF.
2. Multiply the load with distance to find the moment at various points. Anti clockwise BM minus clockwise BM will BM at a point it may be +ve or –ve SF.
3. Shear force maximum at the support.
4. Moment maximum at the support and zero at free end.

#### Simply supported Beam:

1. Find the reactions at the supports.
2. When taking moment to find the reactions consider even the pure moment in the beam, be careful with the direction of the moment. Then follow the SF and BM diagram procedure to complete the figure.
3. Simply add the load from right to find the shear force at various points. Upward SF minus downward SF will give SF at a point it may be +ve or –ve SF.
4. Multiply the load with distance to find the moment at various points. Anti clockwise BM minus clockwise BM will BM at a point it may be +ve or –ve SF.
5. Moment is maximum where SF is zero for pure load only.
6. To find the maximum moment, find section where SF is zero equate upward load to downward load to distance  $x$  from a support. Take that distance to find the maximum moment.
7. Moments are zero at the supports. .

#### Over hanging Beam:

1. Find the reactions at the supports.
2. When taking moment to find the reactions consider even the pure moment in the beam, be careful with the direction of the moment. Then follow the SF and BM diagram procedure to complete the figure.
3. Simply add the load from right to find the shear force at various points. Upward SF minus downward SF will give SF at a point it may be +ve or –ve SF.
4. Multiply the load with distance to find the moment at various points. Anti clockwise BM minus clockwise BM will BM at a point it may be +ve or –ve SF.

5. The moment changes the sign from positive to negative such point is known as point of contraflexure. To find the point of contraflexure find the section where MB is zero equate clockwise moments to anti clockwise moment to distance x from a support.

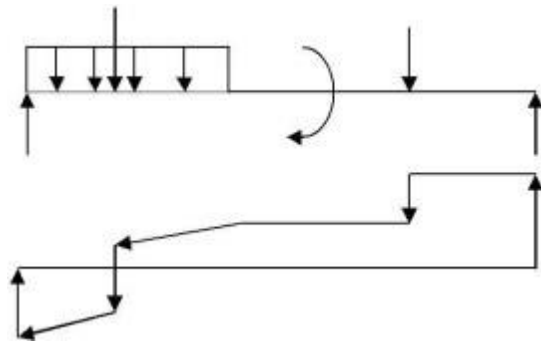
6. Moments are zero at the supports where there is no overhanging, and at the over hanging end.

#### **Drawing Shear force diagram:**

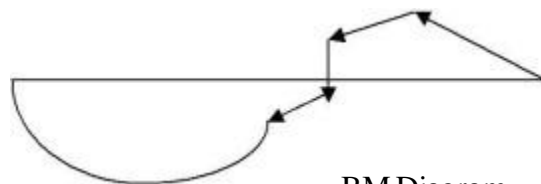
1. Draw a reference line equal to length of the beam to scale.
2. Move the line up if SF is pointing upward or move the line down if SF is pointing downward.
3. When there is no load between loads draw horizontal line parallel to reference line.
4. Point load is represented by vertical line.
5. udl is represented by inclined line.
6. Uniformly varying load is represented by parabola line.
7. Ignore moment for shear force diagram.

#### **Drawing Bending Moment diagram:**

1. Draw a reference line equal to length of the beam to scale.
2. Locate a point to find BM, clockwise is taken as negative and anti clockwise is taken as positive.
3. Draw an inclined line to the point if the moment is due to point load only between sections.
4. Draw a parabolic line to the point if the moment is due to udl load between sections.
5. Draw a vertical line for pure moment on the beam, downward if it is clockwise moment and upward if it is anti clockwise moment.



SF Diagram



BM Diagram

**ending Stress**

$M = WL/4$  Simply support beam point load at mid span

$M = wL^2$

$M = \frac{WL^2}{2}$  Cantilever beam load at distance L from the support

$M = wL^2 / 2$  Cantilever beam of udl throughout the span

Stress is zero at centroid (NA) that is at distance y from the xx-axis and maximum at the top and bottom

**We know,**

$$\frac{M}{I} = \frac{\zeta}{y} = \frac{E}{R}$$

**M** – Bending moment or Moment may vary depending on the load  
example **I**– Moment of Inertia.

$\zeta$  – Stress due to bending moment. To find  $\zeta_c$  then  $y = y_c$  and to find  $\zeta_t$  then  $y = y_t$  - Centroid of the section about xx axis (NA). To find  $\zeta_c$  then  $y = y_c$  and to find  $\zeta_t$  then  $y = y_t$

**E** – Modulus of Elasticity or Young’s modulus.

**R**- Radius of curvature due to bending.

For symmetric section value of  $\zeta_c = \zeta_t$  because  $y_c = y_t$  example, rectangle, circular, and symmetric I section. That is N.A will be at mid point. The value  $y_c = y$  from the bottom to NA for beam under compression and  $y_t = y$  from the top to NA for beam under tension. To find the safe Load or moment find the value of  $\zeta_c/y_c$  and  $\zeta_t/y_t$  and take the least value for safe design.

$I = bd^3$

$I = \pi(D_o^4 - D_i^4)/64$  for hollow pipe and solid rod  $y = D_o/2$  for solid pipe  $D_i = 0$

Centroid (NA) of total section  $y = \text{sum of (area of each section x centroid of each section from xx axis)} / \text{sum of (area of each section)}$  Ref: figure

$$y = \frac{a_1y_1 + a_2y_2 + \dots + a_ny_n}{a_1 + a_2 + \dots + a_n}$$

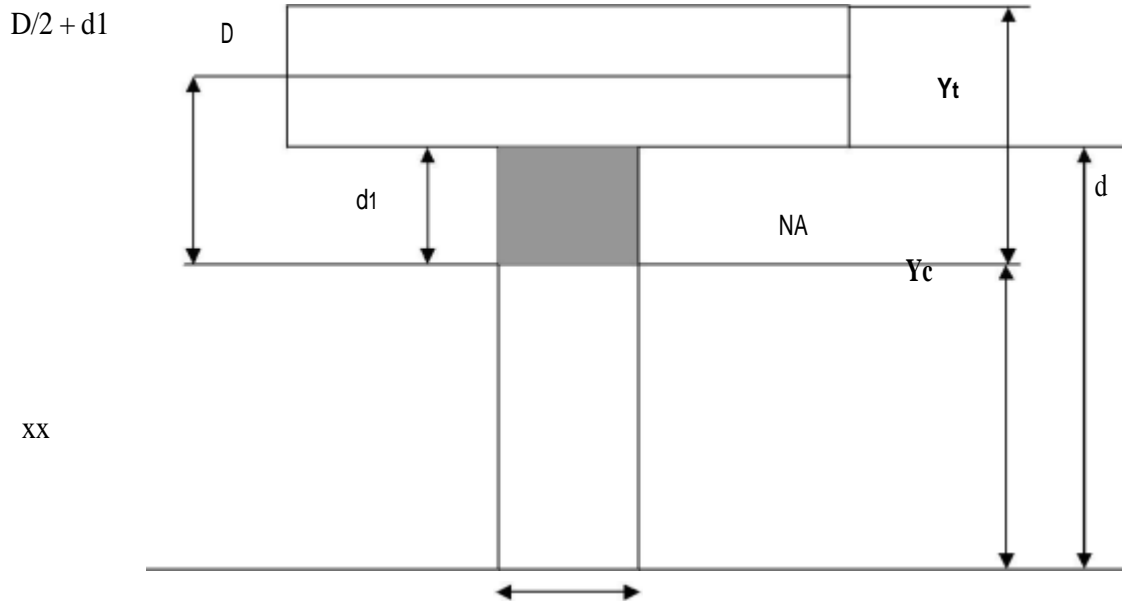
**Substitute the value y in the moment of inertia equation.**

Stress is caused due to Shear force or load. The shear load is right angle to the section. Shear Stress is zero at the top and bottom of the section and it is the maximum at centroid (NA) distance y from the xx-axis.

$$\eta = \frac{FAy}{Ib}$$

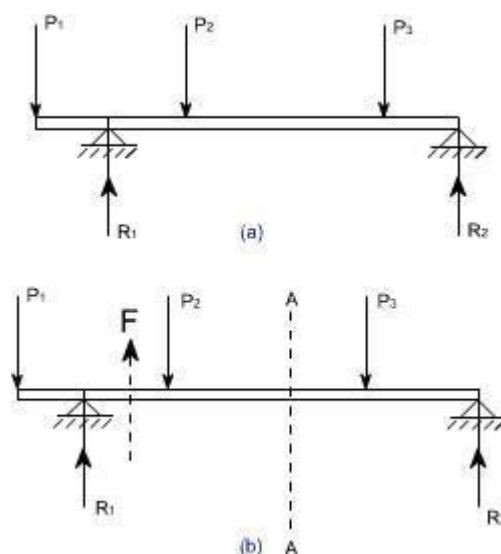
$\eta$ – Shear stress at a point  $F$ – Shear load  $A$  – Area of the section considered.

$y$  – Centroid distance of the section considered from the Neutral axis of the whole section.  $I$ – Inertia of the whole section  $b$ – Width of the section considered.



**Concept of Shear Force and Bending moment in beams:**

When the beam is loaded in some arbitrarily manner, the internal forces and moments are developed and the terms shear force and bending moments come into pictures which are helpful to analyze the beams further. Let us define these terms



**Fig 1**

Now let us consider the beam as shown in fig 1(a) which is supporting the loads  $P_1$ ,  $P_2$ ,  $P_3$  and is simply supported at two points creating the reactions  $R_1$  and  $R_2$  respectively. Now let us assume that the beam is to divided into or imagined to be cut into two portions at a section AA. Now let us assume that the resultant of loads and reactions to the left of AA is „F'

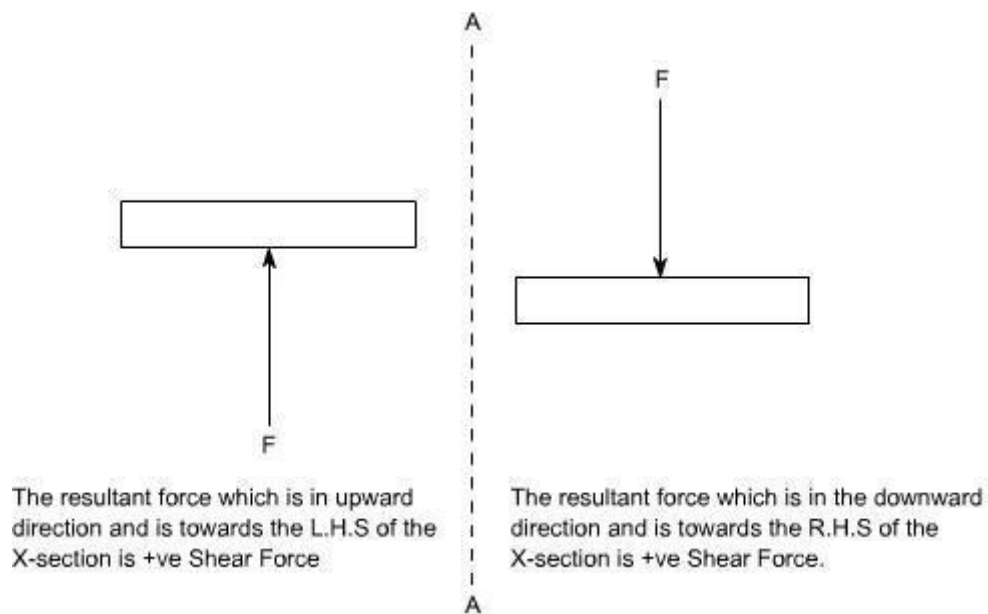
vertically upwards, and since the entire beam is to remain in equilibrium, thus the resultant of forces to the right of AA must also be  $F$ , acting downwards. This forces „ $F$ ’ is as a shear force. The shearing force at any  $x$ - section of a beam represents the tendency for the portion of the beam to one side of the section to slide or shear laterally relative to the other portion.

Therefore, now we are in a position to define the shear force „ $F$ ’ to as follows:

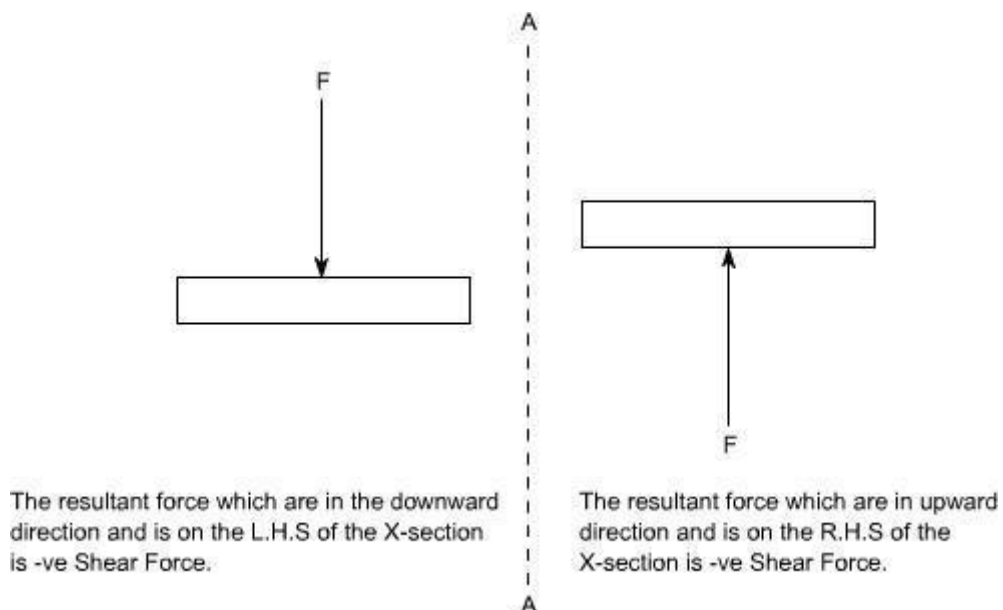
At any  $x$ -section of a beam, the shear force „ $F$ ’ is the algebraic sum of all the lateral components of the forces acting on either side of the  $x$ -section.

**Sign Convention for Shear Force:**

The usual sign conventions to be followed for the shear forces have been illustrated in figures 2 and 3.

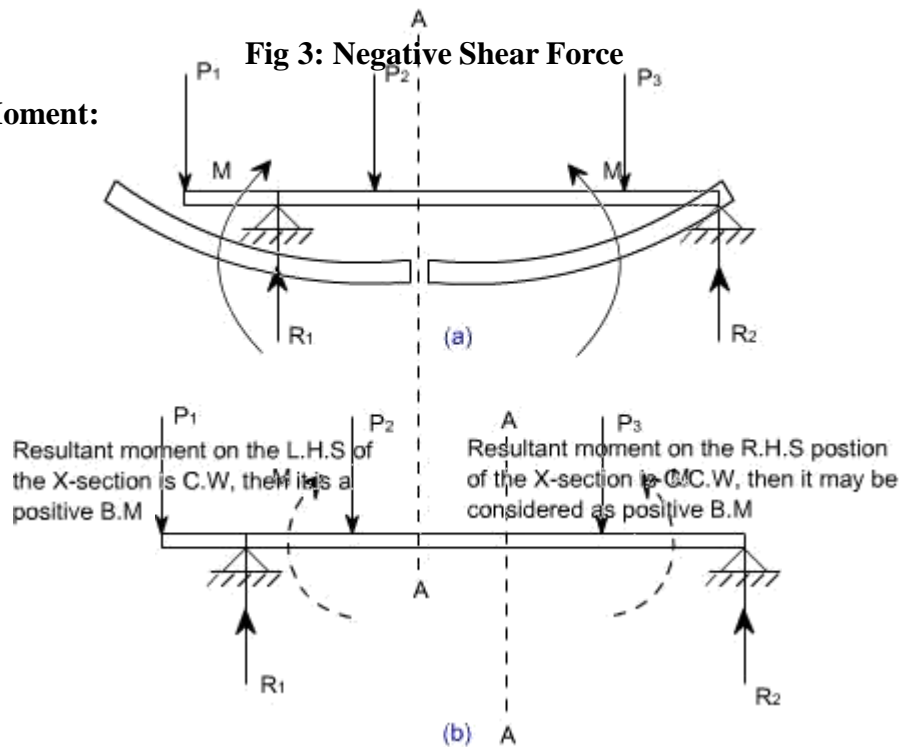


**Fig 2: Positive Shear Force**



**Bending Moment:**

**Fig 4**



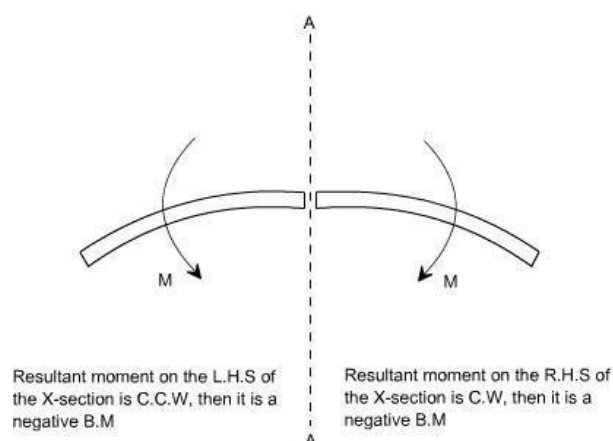
Let us again consider the beam which is simply supported at the two prints, carrying loads  $P_1$ ,  $P_2$  and  $P_3$  and having the reactions  $R_1$  and  $R_2$  at the supports Fig 4. Now, let us imagine that the beam is cut into two portions at the x-section AA. In a similar manner, as done for the case of shear force, if we say that the resultant moment about the section AA of all the loads and reactions to the left of the x-section at AA is  $M$  in C.W direction, then moment of forces to the right of x-section AA must be „ $M'$ “ in

C.C.W. Then „ $M'$ “ is called as the Bending moment and is abbreviated as B.M. Now one can define the bending moment to be simply as the algebraic sum of the moments about an x-section of all the forces acting on either side of the section

**Sign Conventions for the Bending Moment:**

For the bending moment, following sign conventions may be adopted as indicated in Fig 5 and Fig 6.

**Fig 5: Positive Bending Moment**



Some times, the terms „Sagging' and Hogging are generally used for the positive and negative bending moments respectively.

### Bending Moment and Shear Force Diagrams:

The diagrams which illustrate the variations in B.M and S.F values along the length of the beam for any fixed loading conditions would be helpful to analyze the beam further.

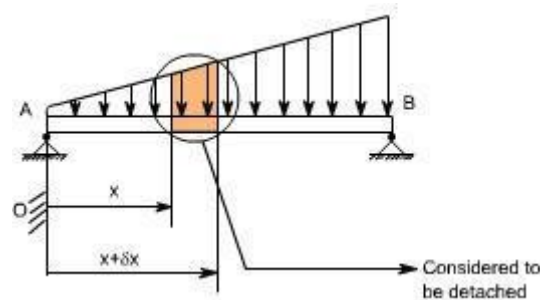
Thus, a shear force diagram is a graphical plot, which depicts how the internal shear force „F' varies along the length of beam. If  $x$  denotes the length of the beam, then  $F$  is function  $x$  i.e.  $F(x)$ .

Similarly a bending moment diagram is a graphical plot which depicts how the internal bending moment „M' varies along the length of the beam. Again  $M$  is a function  $x$  i.e.  $M(x)$ .

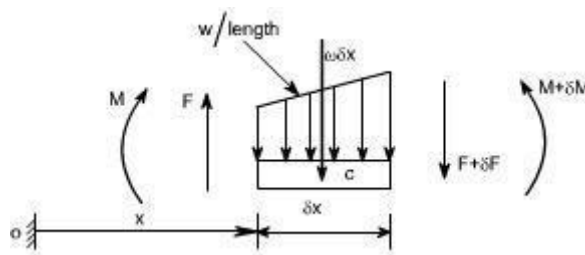
### Basic Relationship Between The Rate of Loading, Shear Force and Bending Moment:

The construction of the shear force diagram and bending moment diagrams is greatly simplified if the relationship among load, shear force and bending moment is established.

Let us consider a simply supported beam AB carrying a uniformly distributed load  $w$ /length. Let us imagine to cut a short slice of length  $dx$  cut out from this loaded beam at distance „ $x$ ' from the origin „0'.



Let us detach this portion of the beam and draw its free body diagram.



The forces acting on the free body diagram of the detached portion of this loaded beam are the following

- The shearing force  $F$  and  $F + \delta F$  at the section  $x$  and  $x + \delta x$  respectively.
- The bending moment at the sections  $x$  and  $x + \delta x$  be  $M$  and  $M + dM$  respectively.

- Force due to external loading, if „w' is the mean rate of loading per unit length then the total loading on this slice of length  $\delta x$  is  $w \cdot \delta x$ , which is approximately acting through the centre „c'. If the loading is assumed to be uniformly distributed then it would pass exactly through the centre „c'.

This small element must be in equilibrium under the action of these forces and couples. Now let us take the moments at the point „c'. Such that

$$M + F \cdot \frac{\delta x}{2} + (F + \delta F) \cdot \frac{\delta x}{2} = M + \delta M$$

$$\Rightarrow F \cdot \frac{\delta x}{2} + (F + \delta F) \cdot \frac{\delta x}{2} = \delta M$$

$$\Rightarrow F \cdot \frac{\delta x}{2} + F \cdot \frac{\delta x}{2} + \delta F \cdot \frac{\delta x}{2} = \delta M \text{ [Neglecting the product of } \delta F \text{ and } \delta x \text{ being small quantities]}$$

$$\Rightarrow F \cdot \delta x = \delta M$$

$$\Rightarrow F = \frac{\delta M}{\delta x}$$

Under the limits  $\delta x \rightarrow 0$

$$\boxed{F = \frac{dM}{dx}} \dots\dots\dots (1)$$

Resolving the forces vertically we get

$$w \cdot \delta x + (F + \delta F) = F$$

$$\Rightarrow w = - \frac{\delta F}{\delta x}$$

Under the limits  $\delta x \rightarrow 0$

$$\Rightarrow w = - \frac{dF}{dx} \text{ or } - \frac{d}{dx} \left( \frac{dM}{dx} \right)$$

$$\boxed{w = - \frac{dF}{dx} = - \frac{d^2M}{dx^2}} \dots\dots\dots (2)$$

**Conclusions:** From the above relations, the following important conclusions may be drawn

- From Equation (1), the area of the shear force diagram between any two points, from the basic calculus is the bending moment diagram

$$M = \int F \cdot dx$$

- The slope of bending moment diagram is the shear force, thus

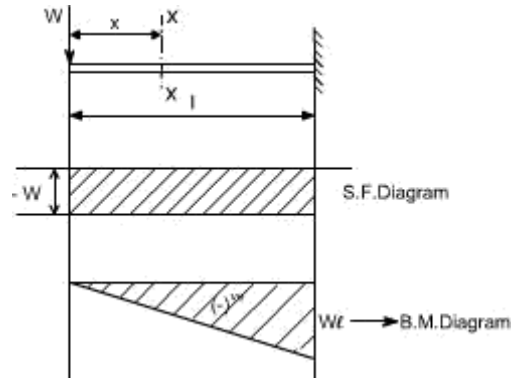
$$F = \frac{dM}{dx}$$

Thus, if  $F=0$ ; the slope of the bending moment diagram is zero and the bending moment is therefore constant.'

- The maximum or minimum Bending moment occurs where

The slope of the shear force diagram is equal to the magnitude of the intensity of the distributed loading at any position along the beam. The -ve sign is as a consequence of our particular choice of sign conventions





It may also be observed that a constant shear force produces a uniform change in the bending moment, resulting in straight line in the moment diagram. If no shear force exists along a certain portion of a beam, then it indicates that there is no change in moment takes place. It may also further observe that  $dm/dx = F$  therefore, from the fundamental theorem of calculus the maximum or minimum moment occurs where the shear is zero. In order to check the validity of the bending moment diagram, the terminal conditions for the moment must be satisfied. If the end is free or pinned, the computed sum must be equal to zero. If the end is built in, the moment computed by the summation must be equal to the one calculated initially for the reaction. These conditions must always be satisfied.

### Illustrative problems:

In the following sections some illustrative problems have been discussed so as to illustrate the procedure for drawing the shear force and bending moment diagrams

#### 1. A cantilever of length carries a concentrated load 'W' at its free end.

Draw shear force and bending moment.

#### Solution:

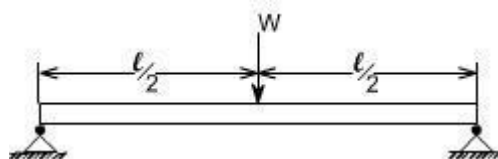
At a section a distance  $x$  from free end consider the forces to the left, then  $F = -W$  (for all values of  $x$ ) -ve sign means the shear force to the left of the  $x$ -section are in downward direction and therefore negative

Taking moments about the section gives (obviously to the left of the section)

$M = -Wx$  (-ve sign means that the moment on the left hand side of the portion is in the anticlockwise direction and is therefore taken as -ve according to the sign convention) so that the maximum bending moment occurs at the fixed end i.e.  $M = -Wl$

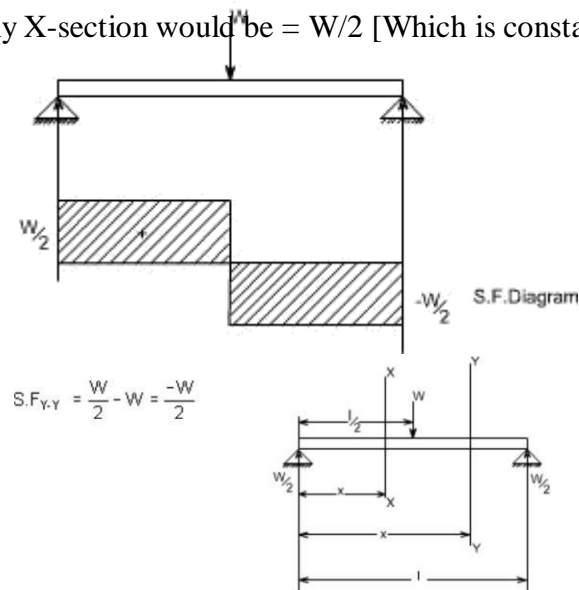
From equilibrium consideration, the fixing moment applied at the fixed end is  $Wl$  and the reaction is  $W$ . the shear force and bending moment are shown as,

#### 2. Simply supported beam subjected to a central load (i.e. load acting at the mid- way)



By symmetry the reactions at the two supports would be  $W/2$  and  $W/2$ . now consider any section X-X from the left end then, the beam is under the action of following forces.

.So the shear force at any X-section would be =  $W/2$  [Which is constant upto  $x < l/2$ ]



If we consider another section Y-Y which is beyond  $l/2$  then

for all values greater =  $l/2$

Hence S.F diagram can be plotted as,

.For B.M diagram:

If we just take the moments to the left of the cross-section,

$$B.M_{x-x} = \frac{W}{2} x \text{ for } x \text{ lies between } 0 \text{ and } l/2$$

$$B.M_{\text{at } x = l/2} = \frac{W}{2} \cdot \frac{l}{2} \text{ i.e. B.M. at } x = 0$$

$$= \frac{Wl}{4}$$

$$B.M_{y-y} = \frac{W}{2} x - W \left( x - \frac{l}{2} \right)$$

Again

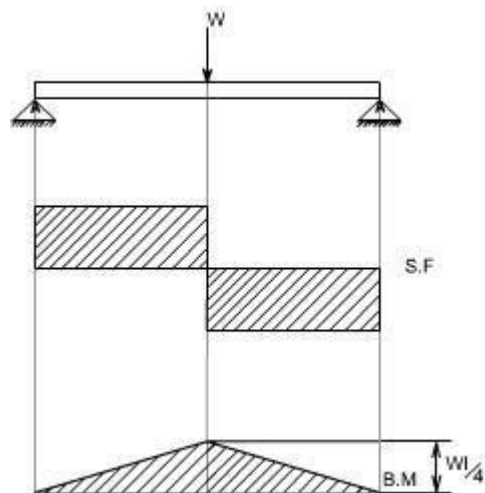
$$= \frac{W}{2} x - Wx + \frac{Wl}{2}$$

$$= -\frac{W}{2} x + \frac{Wl}{2}$$

$$B.M_{\text{at } x = l} = -\frac{Wl}{2} + \frac{Wl}{2}$$

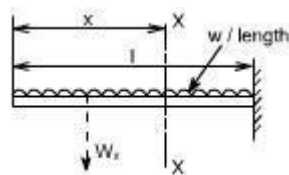
$$= 0$$

Which when plotted will give a straight relation i.e.



It may be observed that at the point of application of load there is an abrupt change in the shear force, at this point the B.M is maximum.

3. A cantilever beam subjected to U.d.L, draw S.F and B.M diagram.



Here the cantilever beam is subjected to a uniformly distributed load whose intensity is given  $w / \text{length}$ .

Consider any cross-section XX which is at a distance of  $x$  from the free end. If we just take the resultant of all the forces on the left of the X-section, then

$$S.F_{xx} = -Wx \text{ for all values of } x \quad (1)$$

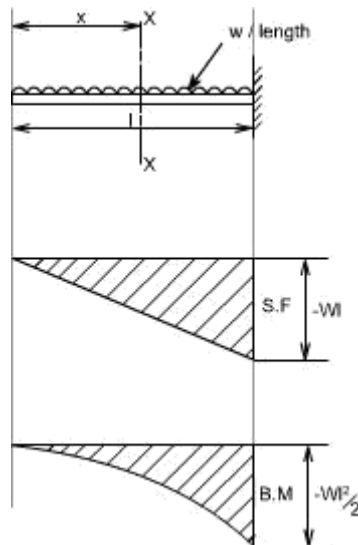
$$S.F_{xx} = 0$$

$$S.F_{xx} \text{ at } x=l = -Wl$$

So if we just plot the equation No. (1), then it will give a straight line relation. Bending Moment at X-X is obtained by treating the load to the left of X-X as a concentrated load of the same value acting through the centre of gravity.

Therefore, the bending moment at any cross-section X-X is

$$\begin{aligned} B.M_{x-x} &= - Wx \frac{x}{2} \\ &= - W \frac{x^2}{2} \end{aligned}$$



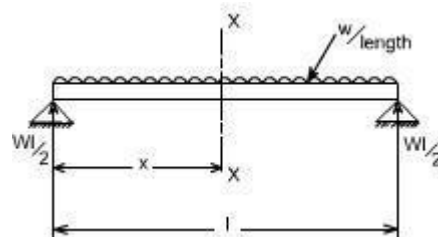
The above equation is a quadratic in  $x$ , when B.M is plotted against  $x$  this will produce a parabolic variation.

The extreme values of this would be at  $x = 0$  and  $x = l$

$$\begin{aligned} \text{B.M. at } x = l &= -\frac{wl^2}{2} \\ &= \frac{wl}{2} - wx \end{aligned}$$

Hence S.F and B.M diagram can be plotted as follows:

**imply supported beam subjected to a uniformly distributed load [U.D.L].**



The total load carried by the span would be

= intensity of loading  $\times$  length

=  $w \times l$

By symmetry the reactions at the end supports are each  $wl/2$

If  $x$  is the distance of the section considered from the left hand end of the beam.

S.F. at any  $x$ -section X-X is

$$S.F. \text{ at } x=0 = \frac{w}{2}$$

$$\text{so at } - wx$$

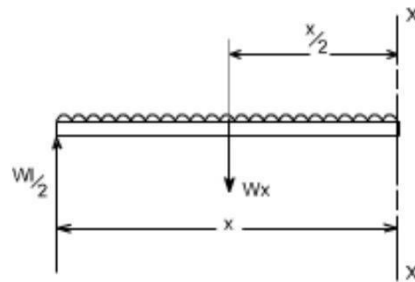
S.F. at  $x=l = 0$  hence the S.F. is zero at the centre

$$= w \left( \frac{l}{2} - x \right)$$

$$S.F. \text{ at } x=l = -\frac{w}{2}$$

Giving a straight relation, having a slope equal to the rate of loading or intensity of the loading.

The bending moment at the section  $x$  is found by treating the distributed load as acting at its centre of gravity, which is at a distance of  $x/2$  from the section



$$B.M._{x-x} = \frac{wx}{2} x - wx \cdot \frac{x}{2}$$

so the

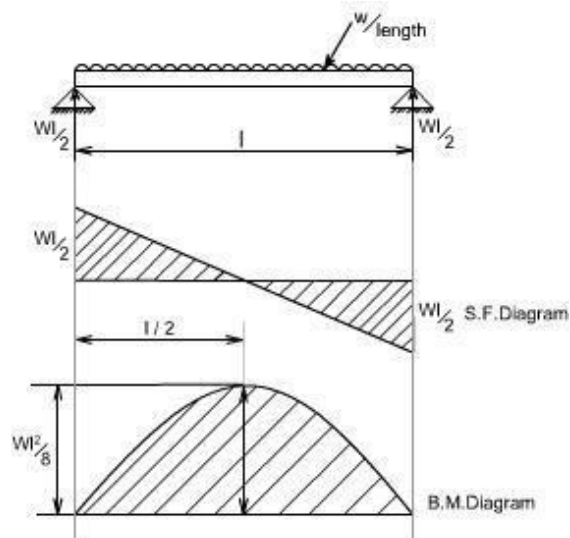
$$= w \cdot \frac{x}{2} (l - 2x) \dots\dots(2)$$

$$B.M. \text{ at } x=0 = 0$$

$$B.M. \text{ at } x=l = 0$$

$$B.M. \Big|_{\text{at } x=l} = -\frac{wl^2}{8}$$

So the equation (2) when plotted against  $x$  gives rise to a parabolic curve and the shear force and bending moment can be drawn in the following way will appear as follows:



### UNIT 3 FLEXURAL AND SHEAR STRESSES IN BEAMS

#### Loading restrictions:

As we are aware of the fact internal reactions developed on any cross-section of a beam may consist

of a resultant normal force, a resultant shear force and a resultant couple. In order to ensure that the

bending effects alone are investigated, we shall put a constraint on the loading such that the resultant

normal and the resultant shear forces are zero on any cross-section perpendicular to the longitudinal

axis of the member,

That means  $F = 0$

since  $\frac{dM}{dx} = F = 0$  or  $M = \text{constant}$ .

Thus, the zero shear force means that the bending moment is constant or the bending is same at every cross-section of the beam. Such a situation may be visualized or envisaged when the beam or some portion of the beam, as been loaded only by pure couples at its ends. It must be recalled that the couples are assumed to be loaded in the plane of symmetry.

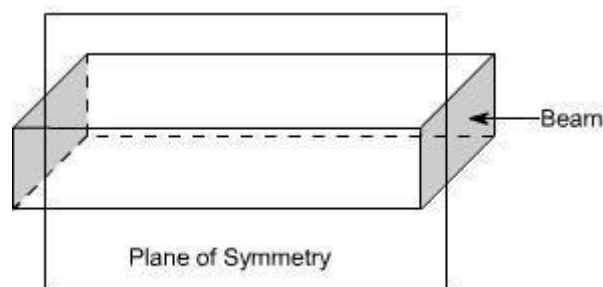
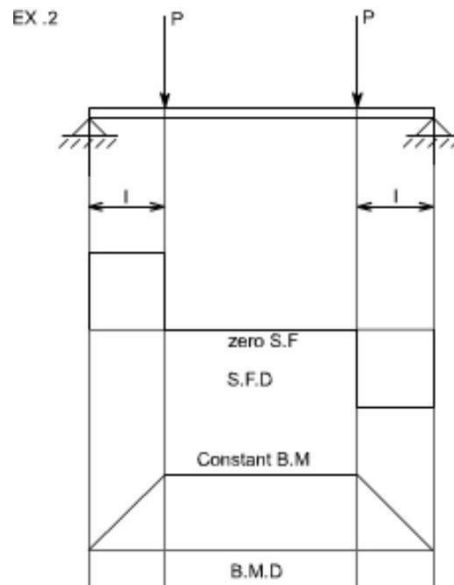


Fig (1)

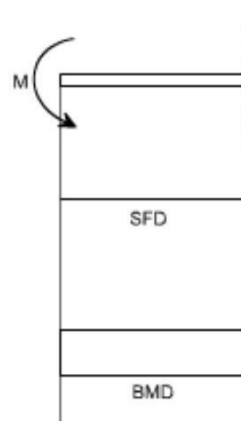


Fig (2)

When a member is loaded in such a fashion it is said to be in **pure bending**. The examples of pure bending have been indicated in EX 1 and EX 2 as shown below :

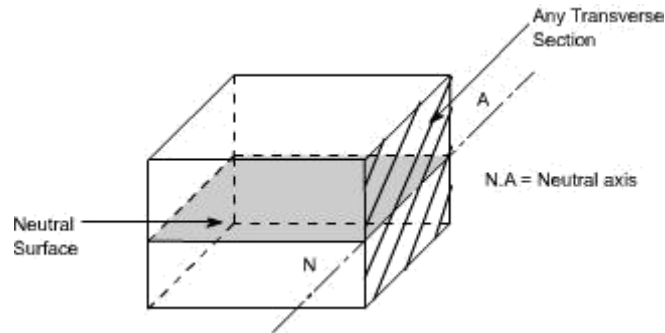


EX. 1



When a beam is subjected to pure bending are loaded by the couples at the ends, certain cross-section gets deformed and we shall have to make out the conclusion that,

1. Plane sections originally perpendicular to longitudinal axis of the beam remain plane and perpendicular to the longitudinal axis even after bending , i.e. the cross- section A'E', B'F' ( refer Fig 1(a) ) do not get warped or curved.
2. In the deformed section, the planes of this cross-section have a common intersection i.e. any time originally parallel to the longitudinal axis of the beam becomes an arc of circle.

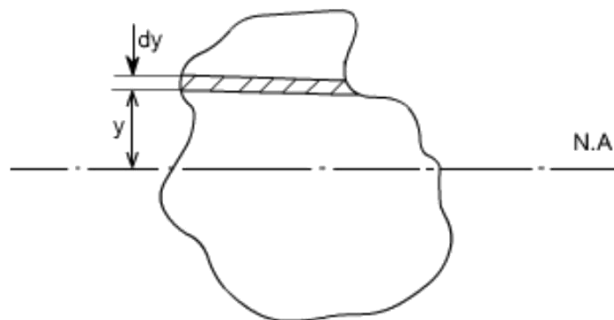


$$= \frac{(R + y)\theta - R\theta}{R\theta} = \frac{R\theta + y\theta - R\theta}{R\theta} = \frac{y}{R}$$

However  $\frac{\text{stress}}{\text{strain}} = E$  where  $E = \text{Young's Modulus of elasticity}$

Therefore, equating the two strains as obtained from the two relations i.e.,

$$\frac{\sigma}{E} = \frac{y}{R} \text{ or } \frac{\sigma}{y} = \frac{E}{R} \quad \dots\dots\dots(1)$$



We know that when a beam is under bending the fibres at the top will be lengthened while at the bottom will be shortened provided the bending moment  $M$  acts at the ends. In between these there are some fibres which remain unchanged in length that is they are not strained, that is they do not carry any stress. The plane containing such fibres is called neutral surface. The line of intersection between the neutral surface and the transverse exploratory section is called the neutral axis Neutral axis (N A) .

**Bending Stresses in Beams or Derivation of Elastic Flexural formula :**

In order to compute the value of bending stresses developed in a loaded beam, let us consider the two cross-sections of a beam **HE** and **GF** , originally parallel as shown in fig 1(a).when the beam is to bend it is assumed that these sections remain parallel i.e. **H'E'** and **G'F'** , the final position of the sections, are still straight lines, they then subtend some angle  $\theta$  .

Consider now fiber **AB** in the material, at a distance  $y$  from the N.A, when the beam bends this will stretch to **A'B'**

Therefore ,

$$\text{strain in fibre AB} = \frac{\text{change in length}}{\text{original length}}$$

$$= \frac{A'B' - AB}{AB}$$

But  $AB = CD$  and  $CD = C'D'$

refer to fig1(a) and fig1(b)

$$\therefore \text{strain} = \frac{A'B' - C'D'}{C'D'}$$



Since CD and C'D' are on the neutral axis and it is assumed that the Stress on the neutral axis zero. Therefore, there won't be any strain on the neutral a

Consider any arbitrary a cross-section of beam, as shown above now the strain on a fibre at a distance „y' from the N.A, is given by the expression

$$\sigma = \frac{E}{R} y$$

if the shaded strip is of area 'dA'

then the force on the strip is

$$F = \sigma \delta A = \frac{E}{R} y \delta A$$

Moment about the neutral axis would be = F . y =  $\frac{E}{R} y^2 \delta A$

The toatl moment for the whole cross-section is therefore equal to

$$M = \sum \frac{E}{R} y^2 \delta A = \frac{E}{R} \sum y^2 \delta A$$

Now the term  $\sum y^2 \delta A$  is the property of the material and is called as a second moment of area of the

cross-section and is denoted by a symbol I.

Therefore

$$M = \frac{E}{R} I \quad \dots\dots\dots(2)$$

combining equation 1 and 2 we get

$$\boxed{\frac{\sigma}{y} = \frac{M}{I} = \frac{E}{R}}$$

**This equation is known as the Bending Theory Equation.**The above proof has involved the assumption of pure bending without any shear force being present.

Therefore this termed as the pure bending equation. This equation gives distribution of stresses which are normal to cross-section i.e. in x-direction.

**Section Modulus:**

From simple bending theory equation, the maximum stress obtained in any cross- section is given as For any given allowable stress the maximum moment which can be accepted by a particular shape of

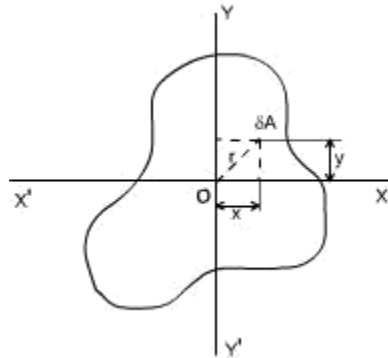
$$\sigma_{\max} = \frac{M}{I} y_{\max}$$

cross-section is therefore

$$M = \frac{I}{y_{\max}} \sigma_{\max}$$

For ready comparison of the strength of various beam cross-section this relationship is some times written in the form

$$M = Z \sigma_{\max} \quad \text{where } Z = \frac{I}{y_{\max}}$$



**Is termed as section modulu**

The higher value of Z for a particular cross-section, the higher the bending moment which it can withstand for a given maximum stress.

**Theorems to determine second moment of area:** There are two theorems which are helpful to determine the value of second moment of area, which is required to be used while solving the simple bending theory equation.

**Second Moment of Area :**

Taking an analogy from the mass moment of inertia, the second moment of area is defined as the summation of areas times the distance squared from a fixed axis. (This property arised while we were driving bending theory equation). This is also known as the moment of inertia. An alternative name given to this is second moment of area, because the first moment being the sum of areas times their distance from a

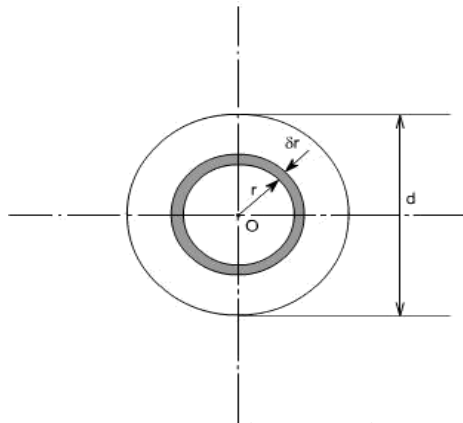
given axis and the second moment being the square of the distance or

$$\int y^2 dA$$

Consider any cross-section having small element of area d A then by the definitio  
 $I_x$ (Mass Moment of Inertia about x-axis) =  $\int x^2 dA$  and  $I_y$ (Mass Moment of Inertia about y-axis) =  $\int y^2 dA$

Now the moment of inertia about an axis through „O' and perpendicular to the plane of figure is called the polar moment of inertia. (The polar moment of inertia is also the area moment of inertia). i.e,

$$\begin{aligned} J &= \text{polar moment of inertia} \\ &= \int r^2 dA \\ &= \int (x^2 + y^2) dA \\ &= \int x^2 dA + \int y^2 dA \\ &= I_x + I_y \\ \text{or } J &= I_x + I_y \quad \dots\dots\dots (1) \end{aligned}$$



The relation (1) is known as the **perpendicular axis theorem** and may be stated as follows:  
 The sum of the Moment of Inertia about any two axes in the plane is equal to the moment of inertia about an axis perpendicular to the plane, the three axes being concurrent, i.e, the three axes exist together.

### CIRCULAR SECTION :

For a circular x-section, the polar moment of inertia may be computed in the following manner

Consider any circular strip of thickness  $\delta r$  located at a radius 'r'. Then the area of the circular strip would be  $dA = 2\pi r \cdot \delta r$

$$J = \int r^2 dA$$

Taking the limits of integration from 0 to  $d/2$

$$J = \int_0^{\frac{d}{2}} r^2 2\pi r \delta r$$

$$= 2\pi \int_0^{\frac{d}{2}} r^3 \delta r$$

$$J = 2\pi \left[ \frac{r^4}{4} \right]_0^{\frac{d}{2}} = \frac{\pi d^4}{32}$$

however, by perpendicular axis theorem

$$J = I_x + I_y$$

But for the circular cross-section, the  $I_x$  and  $I_y$  are both equal being moment of inertia about a diameter

$$I_{dia} = \frac{1}{2} J$$

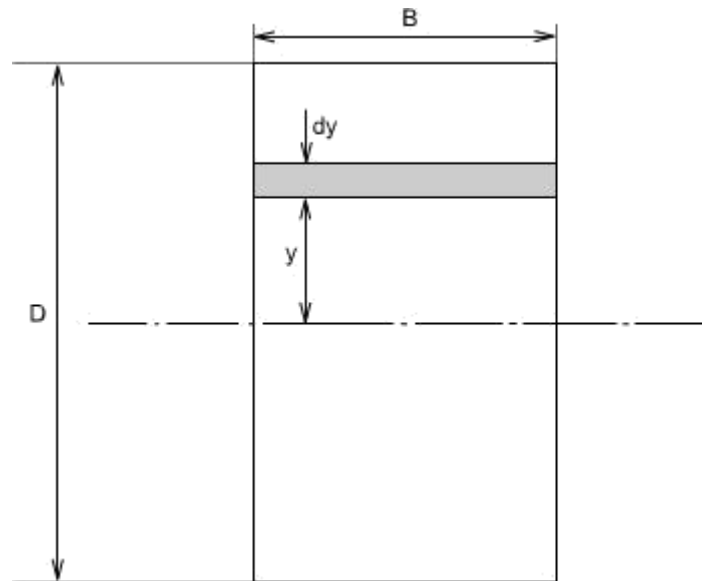
$$I_{dia} = \frac{\pi d^4}{64}$$

for a hollow circular section of diameter  $D$  and  $d$ , the values of  $J$  and  $I$  are defined as

$$J = \frac{\pi(D^4 - d^4)}{32}$$

$$I = \frac{\pi(D^4 - d^4)}{64}$$

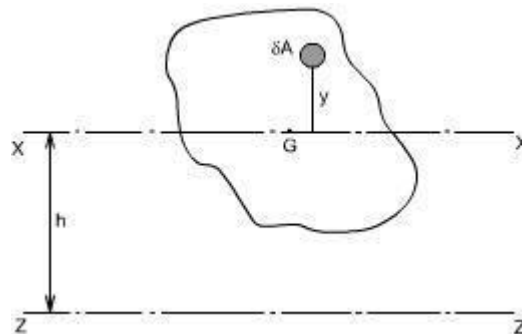
Thus



**Parallel Axis Theorem:**

The moment of inertia about any axis is equal to the moment of inertia about a parallel axis through the centroid plus the area times the square of the distance between the axes.

If „ZZ' is any axis in the plane of cross-section and „XX' is a parallel axis through the centroid G, of



the cross-section, then

$$I_z = \int (y + h)^2 dA \text{ by definition (moment of inertia about an axis ZZ)}$$

$$= \int (y^2 + 2yh + h^2) dA$$

$$= \int y^2 dA + h^2 \int dA + 2h \int y dA$$

$$\text{Since } \int y dA = 0$$

$$= \int y^2 dA + h^2 \int dA$$

$$= \int y^2 dA + h^2 A$$

$$I_z = I_x + Ah^2 \quad I_x = I_G \text{ (since cross-section axes also pass through G)}$$

Where A = Total area of the section

**Rectangular Section:**

For a rectangular x-section of the beam, the second moment of area may be computed as below :

Consider the rectangular beam cross-section as shown above and an element of area  $dA$ , thickness  $dy$

, breadth  $B$  located at a distance  $y$  from the neutral axis, which by symmetry passes through the centre of section. The second moment of area  $I$  as defined earlier would be

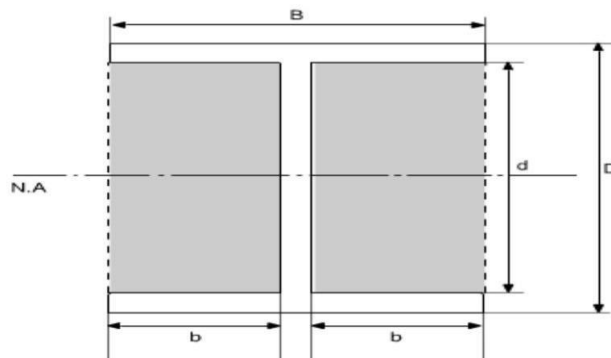
Thus, for the rectangular section the second moment of area about the neutral axis i.e., an axis through the centre is given by

$$\begin{aligned}
 I_{N.A} &= \int y^2 dA \\
 I_{N.A} &= \int_{-\frac{D}{2}}^{\frac{D}{2}} y^2 (B dy) \\
 &= B \int_{-\frac{D}{2}}^{\frac{D}{2}} y^2 dy \\
 I &= B \left[ \frac{y^3}{3} \right]_{-\frac{D}{2}}^{\frac{D}{2}} = \frac{BD^3}{3} \\
 &= \frac{B}{3} \left[ \frac{D^3}{8} - \left( \frac{-D^3}{8} \right) \right] \\
 &= \frac{B}{3} \left[ \frac{D^3}{8} + \frac{D^3}{8} \right] \\
 I_{N.A} &= \frac{BD^3}{12}
 \end{aligned}$$

Similarly, the second moment of area of the rectangular section about an axis through the lower edge of the section would be found using the same procedure but with integral limits of  $0$  to  $D$ .

Therefore

These standard formulae prove very convenient in the determination of  $I_{NA}$  for built up sections which can be conveniently divided into rectangles. For instance if we just want to find out the Moment of Inertia of an I-section, then we can use the above relation.



$$\begin{aligned}
 I_{N.A} &= I_{\text{of dotted rectangle}} - I_{\text{of shaded portion}} \\
 \therefore I_{N.A} &= \frac{BD^3}{12} - 2 \left( \frac{bd^3}{12} \right) \\
 I_{N.A} &= \frac{BD^3}{12} - \frac{bd^3}{6}
 \end{aligned}$$

### Use of Flexure Formula:

#### Illustrative Problems:

An I - section girder, 200mm wide by 300 mm depth flange and web of thickness is 20 mm is used as

simply supported beam for a span of 7 m. The girder carries a distributed load of 5 KN /m and a

concentrated load of 20 KN at mid-span.

Determine the

(i). The second moment of area of the cross-section of the girder

(ii). The maximum stress set up.

#### Solution:

The second moment of area of the cross-section can be determined as follows :

For sections with symmetry about the neutral axis, use can be made of standard I value for a rectangle about an axis through centroid i.e.  $(bd^3)/12$ . The section can thus be divided into convenient rectangles for each of which the neutral axis passes through the centroid. Example in the case enclosing the girder by a rectangle

#### Computation of Bending Moment:

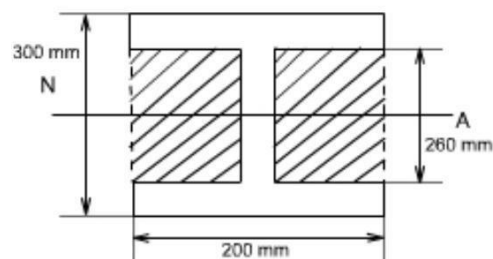
$$\begin{aligned} I_{\text{girder}} &= I_{\text{rectangle}} - I_{\text{shaded portion}} \\ &= \left[ \frac{200 \times 300^3}{12} \right] 10^{-12} - 2 \left[ \frac{90 \times 260^3}{12} \right] 10^{-12} \\ &= (4.5 - 2.64) 10^{-4} \\ &= 1.86 \times 10^{-4} \text{ m}^4 \end{aligned}$$

The maximum stress may be found from the simple bending theory by equation

$$\frac{\sigma}{y} = \frac{M}{I} = \frac{E}{R}$$

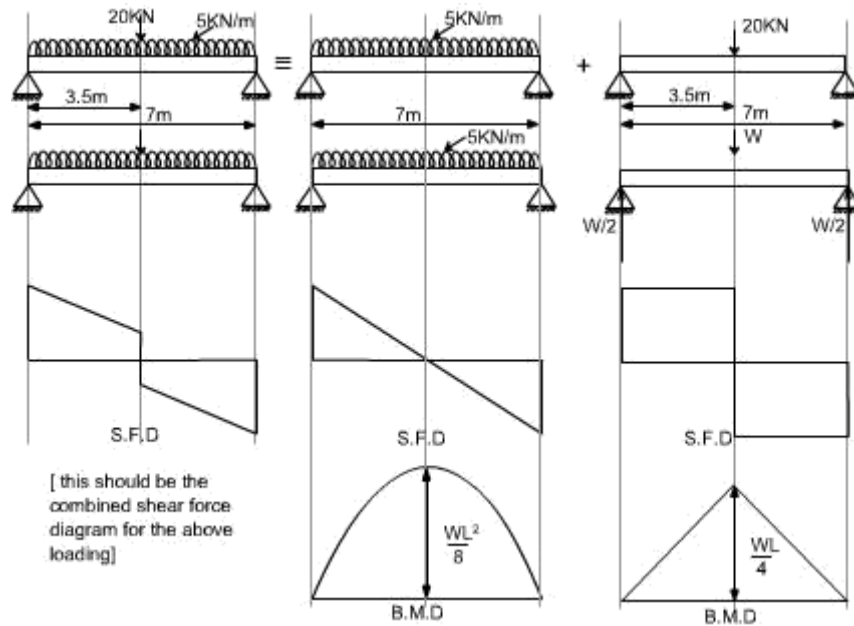
i.e.

$$\sigma_{\text{max}} = \frac{M_{\text{max}}}{I} y_{\text{max}}$$



In this case the loading of the beam is of two types

- (a) Uniformly distributed load
- (b) Concentrated Load



In order to obtain the maximum bending moment the technique will be to consider each loading on the beam separately and get the bending moment due to it as if no other forces acting on the structure and then superimpose the two results.

Hence

$$\begin{aligned}
 M_{\max}^m &= \frac{wL}{4} + \frac{wL^2}{8} \\
 &= \frac{20 \times 10^3 \times 7}{4} + \frac{5 \times 10^3 \times 7^2}{8} \\
 &= (35.0 + 30.63) 10^3 \\
 &= 65.63 \text{ kNm} \\
 \sigma_{\max}^m &= \frac{M_{\max}^m}{I} y_{\max}^m \\
 &= \frac{65.63 \times 10^3 \times 150 \times 10^3}{1.06 \times 10^{-4}} \\
 \sigma_{\max}^m &= 51.8 \text{ MN/m}^2
 \end{aligned}$$

### Shearing Stresses in Beams

All the theory which has been discussed earlier, while we discussed the bending stresses in beams was for the case of pure bending i.e. constant bending moment acts

## UNIT-4

### TORSION OF CIRCULAR SHAFTS

#### Simple or Single shaft

$$\frac{T}{I_p} = \frac{\tau}{r} = \frac{G\theta}{L} \text{--- is general equation to stress and twist due to torsion.}$$

T = Torque or Torsion or Angular Velocity obtained from power  
 $I_p$  = Polar moment of inertia is sum of  $I_{xx}$  and  $I_{yy}$   
 $\tau$  = Shear stress in shaft  
 r = radius of shaft

L = Length of shaft                       $\theta$  = Angle of twist in radian. G or C = Modulus of rigidity

Convert to radian  $180$

P = Hollow shaft

$$I_p = \frac{\pi(D^4 - d^4)}{32} \quad I_p = I/2 \text{ only for circular section}$$

D - External dia and d – internal dia

Solid shaft  $d = 0$

Therefore,  $\pi D I_p = \text{Strength of shaft}$

Angle of twist is,

**Torsional rigidity** is the product of G and  $I_p$  which is  $G I_p$ .  $Z_p$  is known as polar modulus which is ratio of Polar inertia over the distance from NA.

Conditions: Torque is same in shafts  $T_1 = T_2$

Twist  $\theta = \theta_1 + \theta_2$  Shafts rotate in same direction

Twist  $\theta = \theta_1 - \theta_2$  Shafts rotate in opposite direction

Choose the least Torque between shafts for safe stress and angle of twist.

#### Shafts in parallel:

Conditions: Total Torque  $T = T_1 + T_2$

Twist is same in both shaft  $\theta_1 = \theta_2$

The shafts may be of same material or different material, which is known as composite shaft.



### **Strain energy or Torsional resilience in shaft:**

It is the amount of energy stored when the shaft is in twisted position.

$$\text{Torsional energy } U = \text{Average Torque } \times \text{ angle of twist} \\ T \times \theta$$

When U is divided by the volume of the shaft, is known as strain energy per unit volume.

### **Shaft coupled:**

The shaft is joined together when the length is not sufficient this is known as coupling of shaft. It is done in two methods.

1. Using bolts
2. Using key

### **Bolt method**

T can be obtained from shaft expression for bolt and keyed shaft.

$$T = \frac{\zeta I_p}{r} \quad \text{or from Power expression } P = \frac{2\pi NT}{60}$$

T is torque in shaft which is transmitted to the coupled shaft through bolts or key. Therefore torque in bolts or key is equal to torque in shaft.

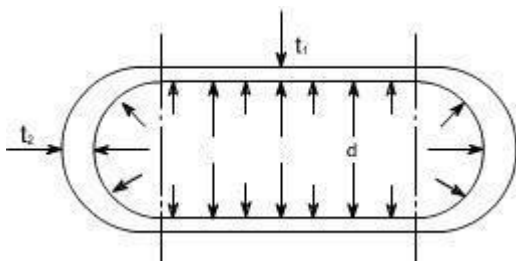
T = no. of bolts x area of bolt x stress in bolt x radius of bolt circle

$$\text{Therefore } T = n \times \Pi db$$

### **Cylindrical Vessel with Hemispherical Ends:**

Let us now consider the vessel with hemispherical ends. The wall thickness of the cylindrical and hemispherical portion is different. While the internal diameter of both the portions is assumed to be equal

Let the cylindrical vessel is subjected to an internal pressure p.



### **For the Cylindrical Portion**

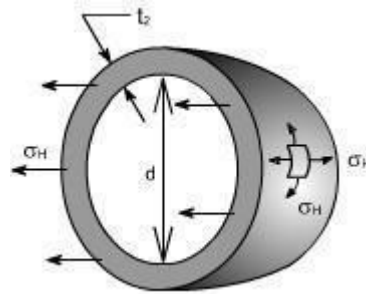
$$\text{hoop or circumferential stress} = \sigma_{HC} \quad \text{'c' here signifies the cylindrical portion.} \\ = \frac{pd}{2t_1}$$

$$\text{longitudinal stress} = \sigma_{LC} \\ = \frac{pd}{4t_1}$$

$$\text{hoop or circumferential strain } \epsilon_2 = \frac{\sigma_{HC}}{E} - \nu \frac{\sigma_{LC}}{E} = \frac{pd}{4t_1 E} [2 - \nu]$$

$$\text{or } \epsilon_2 = \frac{pd}{4t_1 E} [2 - \nu]$$

**For The Hemispherical Ends:**



Because of the symmetry of the sphere the stresses set up owing to internal pressure will be two mutually perpendicular hoops or circumferential stresses of equal values. Again the radial stresses are neglected in comparison to the hoop stresses as with this cylinder having thickness to diameter less than 1:20.

Consider the equilibrium of the half – sphere

Force on half-sphere owing to internal pressure = pressure x projected Area

$$= p \cdot \frac{d^2}{4}$$

$$\text{Resisting force} = \sigma_H \cdot \pi \cdot d \cdot t_2$$

$$\therefore p \cdot \frac{\pi \cdot d^2}{4} = \sigma_H \cdot \pi \cdot d \cdot t_2$$

$$\Rightarrow \sigma_H \text{ (for sphere)} = \frac{pd}{4t_2}$$

$$\text{similarly the hoop strain} = \frac{1}{E} [\sigma_H - \nu \cdot \sigma_H] = \frac{\sigma_H}{E} [1 - \nu] = \frac{pd}{4t_2 E} [1 - \nu] \text{ or } \epsilon_{2s} = \frac{pd}{4t_2 E} [1 - \nu]$$

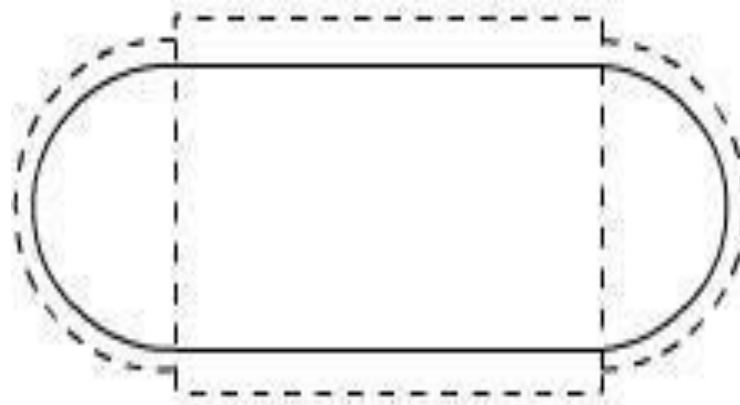


Fig – shown the (by way of dotted lines) the tendency, for the cylindrical portion and the spherical ends to expand by a different amount under the action of internal pressure. So owing to difference in stress, the two portions (i.e. cylindrical and spherical ends) expand by a different amount. This incompatibility of deformations causes a local bending and shearing stresses in the neighborhood of the joint. Since there must be physical continuity between the ends and the cylindrical portion, for this reason, properly curved ends must be used for pressure vessels.

Thus equating the two strains in order that there shall be no distortion of the junction

$$\frac{pd}{4t_1E}[2-\nu] = \frac{pd}{4t_2E}[1-\nu] \text{ or } \frac{t_2}{t_1} = \frac{1-\nu}{2-\nu}$$

But for general steel works  $\nu = 0.3$ , therefore, the thickness ratios becomes

$$t_2 / t_1 = 0.7/1.7$$

i.e. the thickness of the cylinder walls must be approximately 2.4 times that of the hemispheroid ends for no distortion of the junction to occur.

**SUMMARY OF THE RESULTS :** Let us summaries the derived results

(A) The stresses set up in the walls of a thin cylinder owing to an internal pressure  $p$  are :

(i) Circumferential or hoop stress

$$H = pd/2t$$

(ii) Longitudinal or axial stress

$$L = pd/4t$$

Where  $d$  is the internal diameter and  $t$  is the wall thickness of the cylinder. then

$$\text{Longitudinal strain } L = 1/E [L - H]$$

□ □ □

$$\text{Hoop strain } H = 1/E [H - \nu L]$$

(B) Change of internal volume of cylinder under pressure

$$= \frac{pd}{4tE} [5 - 4\nu] V$$

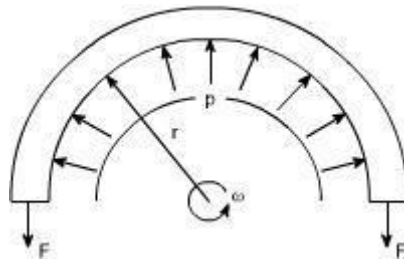
(C) For thin spheres circumferential or hoop stress

$$\sigma_H = \frac{pd}{4t}$$

### Thin rotating ring or cylinder

Consider a thin ring or cylinder as shown in Fig below subjected to a radial internal pressure  $p$  caused by the centrifugal effect of its own mass when rotating. The centrifugal effect on a unit length of the circumference is

$$p = m \omega^2 r$$



**Fig 19.1: Thin ring rotating with constant angular velocity**

Here the radial pressure „ $p$ ’ is acting per unit length and is caused by the centrifugal effect of its own mass when rotating.

Thus considering the equilibrium of half the ring shown in the figure,  $2F = p \times 2r$  (assuming unit length), as  $2r$  is the projected area  $F = pr$

Where  $F$  is the hoop tension set up owing to rotation.

The cylinder wall is assumed to be so thin that the centrifugal effect can be assumed constant across the wall thickness.

$$F = \text{mass} \times \text{acceleration} = m \omega^2 r \times r$$

This tension is transmitted through the complete circumference and therefore is resisted by the complete cross – sectional area.

$$\text{hoop stress} = F/A = m \omega^2 r^2 / A$$

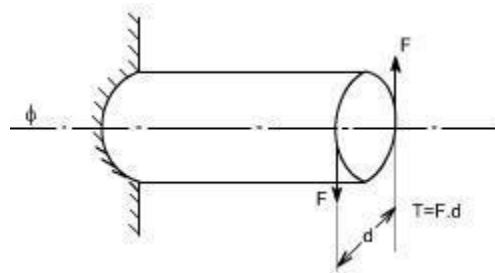
Where A is the cross – sectional area of the ring.

Now with unit length assumed m/A is the mass of the material per unit volume, i.e. the density  $\rho$ .

$$\text{hoop stress } \sigma_H = \rho \omega^2 r^2$$

### Torsion of circular shafts

**Definition of Torsion:** Consider a shaft rigidly clamped at one end and twisted at the other end by a torque  $T = F.d$  applied in a plane perpendicular to the axis of the bar such a shaft is said to be in torsion.



**Effects of Torsion:** The effects of a torsional load applied to a bar are

- (i) To impart an angular displacement of one end cross – section with respect to the other end.
- (ii) To setup shear stresses on any cross section of the bar perpendicular to its axis.

### Assumption:

- (i) The material is homogenous i.e of uniform elastic properties exists throughout the material.
- (ii) The material is elastic, follows Hook's law, with shear stress proportional to shear strain.
- (iii) The stress does not exceed the elastic limit.
- (iv) The circular section remains circular
- (v) Cross section remain plane.
- (vi) Cross section rotate as if rigid i.e. every diameter rotates through the same angle.

Consider now the solid circular shaft of radius R subjected to a torque T at one end, the other end being fixed Under the action of this torque a radial line at the free end of the shaft twists through an angle of distortion of the shaft i.e the shear strain.

Since angle in radius = arc /

$$\text{Radius arc } AB = R$$

From the definition of Modulus of rigidity or Modulus of elasticity in shear

$$G = \frac{\text{shear stress}(\tau)}{\text{shear strain}(\gamma)}$$

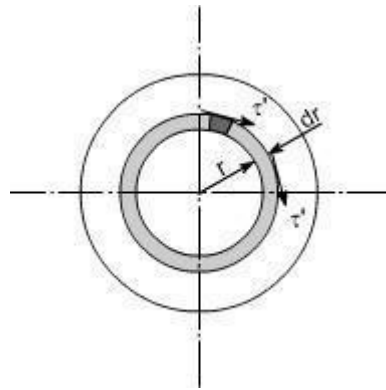
where  $\gamma$  is the shear strain set up at radius R.

$$\text{Then } \frac{\tau}{G} = \gamma$$

Equating the equations (1) and (2) we get  $\frac{R\theta}{L} = \frac{\tau}{G}$

$$\frac{\tau}{R} = \frac{G\theta}{L} \left( = \frac{\tau'}{r} \right) \text{ where } \tau' \text{ is the shear stress at any radius } r.$$

**Stresses:** Let us consider a small strip of radius  $r$  and thickness  $dr$  which is subjected to shear stress  $\tau$ .



The force set up on each element = stress x area

$$\text{i.e. } \tau' = \frac{G\theta r}{L}$$

$$\text{we get } T = \int_0^R 2\pi \frac{G\theta}{L} r^3 dr$$

$$T = \frac{2\pi G\theta}{L} \int_0^R r^3 dr$$

$$= \frac{2\pi G\theta}{L} \left[ \frac{R^4}{4} \right]_0^R$$

$$= \frac{G\theta}{L} \cdot \frac{2\pi R^4}{4}$$

$$= \frac{G\theta}{L} \cdot \frac{\pi R^4}{2}$$

$$= \frac{G\theta}{L} \left[ \frac{\pi d^4}{32} \right] \text{ now substituting } R = d/2$$

$$= \frac{G\theta}{L} J$$

since  $\frac{\pi d^4}{32} = J$  the polar moment of inertia

$$\text{or } \frac{T}{J} = \frac{G\theta}{L} \quad \dots\dots(2)$$

if we combine the equation no.(1) and (2) we get  $\boxed{\frac{T}{J} = \frac{\tau'}{r} = \frac{G\theta}{L}}$

The total torque T on the section, will be the sum of all the contributions.

Since  $\tau'$  varies with radius so writing down  $\tau'$  in terms of r from the equation (1).

Where

T = applied external Torque, which is constant over Length L;

J = Polar moment of Inertia

$$= \frac{\pi d^4}{32} \text{ for solid shaft}$$

$$= \frac{\pi(D^4 - d^4)}{32} \text{ for a hollow shaft.}$$

[ D = Outside diameter ; d = inside

diameter ] G = Modules of rigidity (or Modulus of elasticity in shear)

$\theta$  = It is the angle of twist in radians on a length L.

**Tensional Stiffness:** The tensional stiffness k is defined as the torque per radius twist i.e,  $k = T/\theta = GJ / L$

## **TORSION OF HOLLOW SHAFTS:**

From the torsion of solid shafts of circular x – section , it is seen that only the material at the outer surface of the shaft can be stressed to the limit assigned as an

allowable working stresses. All of the material within the shaft will work at a lower stress and is not being used to full capacity. Thus, in these cases where the weight reduction is important, it is advantageous to use hollow shafts. In discussing the torsion of hollow shafts the same assumptions will be made as in the case of a solid shaft. The general torsion equation as we have applied in the case of torsion of solid shaft will hold good

Hence by examining the equation (1) and (2) it may be seen that the  $\tau_{\max}^m$  in the case of hollow shaft is 6.6% larger than in the case of a solid shaft having the same outside diameter.

### **Reduction in weight:**

$$\frac{T}{J} = \frac{\tau}{r} = \frac{G.\theta}{l}$$

For the hollow shaft

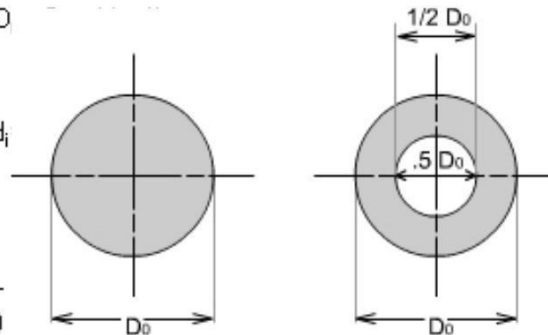
$$J = \frac{\pi(D_0^4 - d_i^4)}{32} \quad \text{where } D_0 = \text{outside diameter}$$

$$\tau_{\max}^m |_{\text{solid}} = \frac{16T}{\pi D_0^3}$$

$$\tau_{\max}^m |_{\text{hollow}} = \frac{T.D_0/2}{\frac{\pi}{32}(D_0^4 - d_i^4)}$$

$$= \frac{16T.D_0}{\pi D_0^4 [1 - (d_i/D_0)^4]}$$

$$= \frac{16T}{\pi D_0^3 [1 - (1/2)^4]} = 1.066 \cdot \frac{16T}{\pi D_0^3} \quad (2)$$



Considering a solid and hollow shafts of the same length 'l' and density ' $\rho$ ' with  $d_i = 1/2 D_0$ .

Weight of hollow shaft

$$= \left[ \frac{\pi D_0^2}{4} - \frac{\pi (D_0/2)^2}{4} \right] l \times \rho$$

$$= \left[ \frac{\pi D_0^2}{4} - \frac{\pi D_0^2}{16} \right] l \times \rho$$

$$= \frac{\pi D_0^2}{4} [1 - 1/4] l \times \rho$$

$$= 0.75 \frac{\pi D_0^2}{4} l \times \rho$$

$$\text{Weight of solid shaft} = \frac{\pi D_0^2}{4} l \times \rho$$

$$\text{Reduction in weight} = (1 - 0.75) \frac{\pi D_0^2}{4} l \times \rho$$

$$= 0.25 \frac{\pi D_0^2}{4} l \times \rho$$

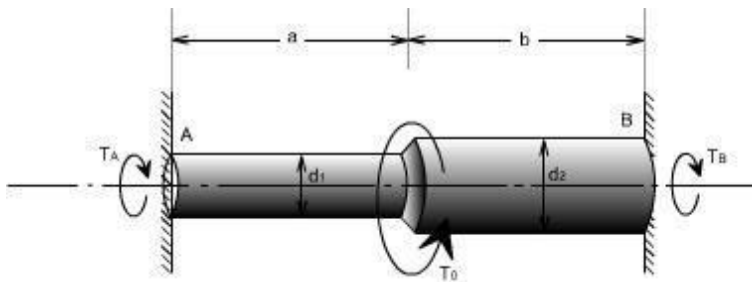
Hence the reduction in weight would be just 25%.



## **Illustrative Examples :**

### **Problem 1**

A stepped solid circular shaft is built in at its ends and subjected to an externally applied torque.  $T_0$  at the shoulder as shown in the figure. Determine the angle of along the entire of the shoulder section where  $T_0$  is length of the beam. rotation  $\phi_0$



## **Closed Coiled helical Spring**

### **Closed Coiled helical springs subjected to axial loads:**

**Definition:** A spring may be defined as an elastic member whose primary function is to deflect or distort under the action of applied load; it recovers its original shape when load is released. or

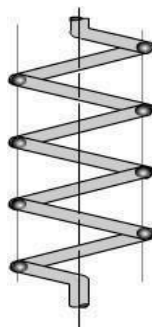
Springs are energy absorbing units whose function is to store energy and to restore it slowly or rapidly depending on the particular application.

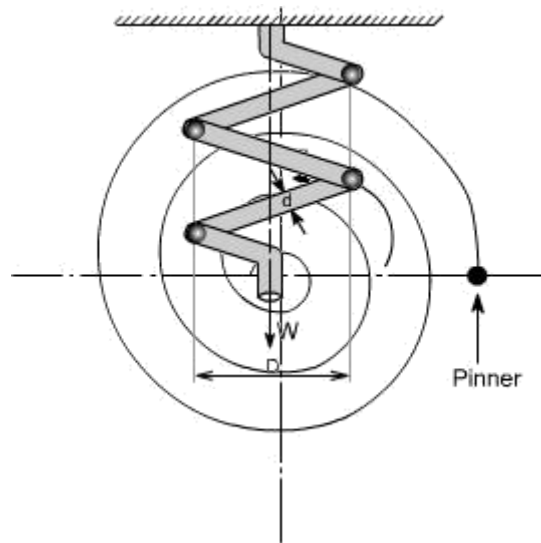
### **Important types of springs are:**

There are various types of springs such as

(i) **helical spring:** They are made of wire coiled into a helical form, the load being applied along the axis of the helix. In these type of springs the major stresses is torsional shear stress due to twisting. They are both used in tension and compression.

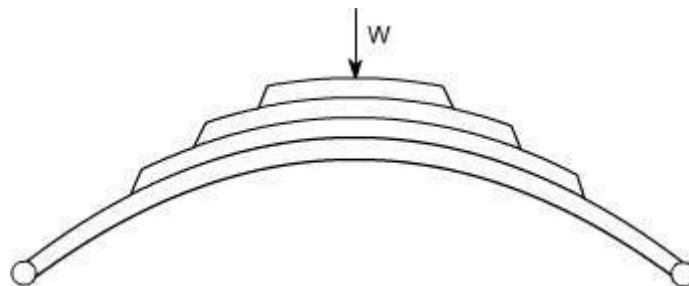
(ii) **Spiral springs:** They are made of flat strip of metal wound in the form of spiral and loaded in torsion.





**(iv) Leaf springs:** They are composed of flat bars of varying lengths clamped together so as to obtain greater efficiency. Leaf springs may be full elliptic, semi elliptic or cantilever types, In these type of springs the major stresses which come into picture are tensile & compressive.

These type of springs are used in the automobile suspension system.



#### **Uses of springs :**

- (a) To apply forces and to control motions as in brakes and clutches.
- (b) To measure forces as in spring balance.
- (c) To store energy as in clock springs.
- (d) To reduce the effect of shock or impact loading as in carriage springs.
- (e) To change the vibrating characteristics of a member as inflexible mounting of motors.

#### **Derivation of the Formula :**

In order to derive a necessary formula which governs the behaviour of springs, consider a closed coiled spring subjected to an axial load  $W$ .

Let

$W$  = axial load

$D$  = mean coil diameter

$d$  = diameter of spring wire  $n$  =

number of active coils

$C = \text{spring index} = D / d$  For circular wires  $l =$

length of spring wire

$G = \text{modulus of rigidity}$   $x =$

deflection of spring  $q =$

Angle of twist

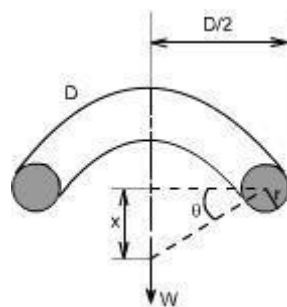
when the spring is being subjected to an axial load to the wire of the spring gets be twisted like a shaft.

If  $q$  is the total angle of twist along the wire and  $x$  is the deflection of spring under the action of load

$W$  along the axis of the coil, so that

$x = D / 2 . <$

again  $l = < D n$  [ consider ,one half turn of a close coiled helical spring ]



**Assumptions:** (1) The Bending & shear effects may be neglected

(2) For the purpose of derivation of formula, the helix angle is considered to be so small that it may be neglected.

Any one coil of a such a spring will be assumed to lie in a plane which is nearly  $\perp$  to the axis of the spring. This requires that adjoining coils be close together. With this limitation, a section taken perpendicular to the axis the spring rod becomes nearly vertical. Hence to maintain equilibrium of a segment of the spring, only a shearing force  $V = F$  and Torque  $T = F \cdot r$  are required at any X – section. In the analysis of springs it is customary to assume that the shearing stresses caused by the direct shear force is uniformly distributed and is negligible so applying the torsion formula.

Using the torsion formula i.e

$$\frac{T}{J} = \frac{\tau}{r} = \frac{G \cdot \theta}{l}$$

and substituting  $J = \frac{\pi d^4}{32}$ ;  $T = w \cdot \frac{d}{2}$

$$\theta = \frac{2 \cdot x}{D}; l = \pi D \cdot x$$

$$K = \frac{4c-1}{4c-4} + \frac{0.615}{c}$$

### **SPRING DEFLECTION**

$$\frac{w.d/2}{\frac{\pi d^4}{32}} = \frac{G.2x/D}{\pi D.n}$$

Thus,

$$x = \frac{8w.D^3.n}{G.d^4}$$

**Spring stiffness:** The stiffness is defined as the load per unit deflection therefore

$$k = \frac{w}{x} = \frac{w}{\frac{8w.D^3.n}{G.d^4}}$$

Therefore

$$k = \frac{G.d^4}{8.D^3.n}$$

### **Shear stress**

$$\frac{w.d/2}{\frac{\pi d^4}{32}} = \frac{\tau_{max}}{d/2}$$

$$\text{or } \tau_{max} = \frac{8wD}{\pi d^3}$$

### **WAHL'S FACTOR :**

In order to take into account the effect of direct shear and change in coil curvature a stress factor is defined, which is known as Wahl's factor

K = Wahl's factor and is defined as Where C = spring index

$$= D/d$$

if we take into account the Wahl's factor than the formula for the shear stress

$$\text{becomes } \tau_{max} = \frac{16.T.k}{\pi d^3}$$

**Strain Energy :** The strain energy is defined as the energy which is stored within a material when the work has been done on the material.

$$x = \frac{8wD^3 \cdot n}{G \cdot d^4}$$

on substituting the relevant parameters we get

$$50 = \frac{8 \cdot 5000 \cdot (0.0314 d^3)^3 \cdot 8}{83,000 \cdot d^4}$$

$$d = 13.32 \text{ mm}$$

In the case of a spring the strain energy would be due to bending and the strain energy due to bending is given by the expansion

$$U = \frac{T^2 L}{2EI}$$

$$L = \pi D n$$

$$I = \frac{\pi d^4}{64}$$

so after substitution we get

$$U = \frac{32 T^2 D n}{E \cdot d^4}$$

**Example:** A close coiled helical spring is to carry a load of 5000N with a deflection of 50 mm and a maximum shearing stress of 400 N/mm<sup>2</sup>. if the number of active turns or active coils is 8. Estimate the following:

- (i) wire diameter
- (ii) mean coil diameter
- (iii) weight of the spring.

Assume  $G = 83,000 \text{ N/mm}^2$  ;  $\rho = 7700 \text{ kg/m}^3$

**solution :**

(i) for wire diameter if  $W$  is the axial load, then

$$\frac{w \cdot d/2}{\frac{\pi d^4}{32}} = \frac{T_{\max}}{d/2}$$

$$D = \frac{400}{d/2} \cdot \frac{\pi d^4}{32} \cdot \frac{2}{W}$$

$$D = \frac{400 \cdot \pi d^3 \cdot 2}{5000 \cdot 16}$$

$$D = 0.0314 d^3$$

Further, deflection is given as

Therefore,

$$D = 0.0314 \times (13.317)^3 \text{ mm}$$

$$= 74.15 \text{ mm}$$

$$= 74.15 \text{ mm}$$

## Weight

mass or weight = volume . density

= area . length of the spring . density of spring material

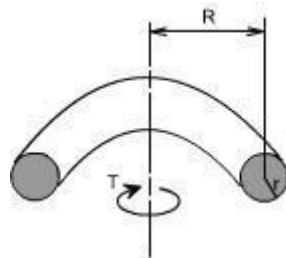
$$= \frac{\pi d^2}{4} \cdot \pi D n \cdot \rho$$

On substituting the relevant parameters we get

$$\text{Weight} = 1.996 \text{ kg}$$

$$= 2.0 \text{ kg}$$

## Close – coiled helical spring subjected to axial torque T or axial couple.



In this case the material of the spring is subjected to pure bending which tends to reduce Radius R of the coils. In this case the bending moment is constant through out the spring and is equal to the applied axial Torque T. The stresses i.e. maximum

$$\begin{aligned}\sigma_{\max} &= \frac{M.y}{I} \\ &= \frac{T.d/2}{\frac{\pi d^4}{64}} \\ \sigma_{\max} &= \frac{32T}{\pi d^3}\end{aligned}$$

bending stress may thus be determined from the bending theory.

### Deflection or wind – up angle:

Under the action of an axial torque the deflection of the spring becomes the “wind – up” angle of the spring which is the angle through which one end turns relative to the

other. This will be equal to the total change of slope along the wire, according to area

– moment theorem

$$\theta = \int_0^L \frac{MdL}{EI} \text{ but } M = T$$

$$= \int_0^L \frac{T \cdot dL}{EI} = \frac{T}{EI} \int_0^L dL$$

Thus, as 'T' remains constant

$$\theta = \frac{T \cdot L}{EI}$$

Further

$$L = \pi D \cdot n$$

$$I = \frac{\pi d^4}{64}$$

Therefore, on substitution, the value of  $\theta$  obtained is

$$\theta = \frac{64TD \cdot n}{E \cdot d^4}$$

**Springs in Series:** If two springs of different stiffness are joined end on and carry a common load  $W$ , they are said to be connected in series and the combined stiffness and deflection are given by the following equation.

$$\frac{W}{k} = x_1 + x_2 = \frac{W}{k_1} + \frac{W}{k_2}$$

or

$$\frac{1}{k} = \frac{1}{k_1} + \frac{1}{k_2}$$



**Springs in parallel:** If the two spring are joined in such a way that they have a common deflection, 'x'

; then they are said to be connected in parallel. In this case the load carried is shared between the two springs and total load  $W = W_1 + W_2$

$$x = \frac{W}{k} = \frac{W_1}{k_1} = \frac{W_2}{k_2}$$

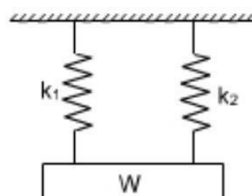
$$\text{Thus } W_1 = \frac{Wk_1}{k}$$

$$W_2 = \frac{Wk_2}{k}$$

Further

$$W = W_1 + W_2$$

$$\text{thus } k = k_1 + k_2$$



## UNIT 5

### Columns and Struts

#### Introduction:

Structural members which carry compressive loads may be divided into two broad categories depending on their relative lengths and cross-sectional dimensions.

#### Columns:

Short, thick members are generally termed columns and these usually fail by crushing when the yield stress of the material in compression is exceeded.

#### Struts:

Long, slender columns are generally termed as struts, they fail by buckling some time before the yield stress in compression is reached. The buckling occurs owing to one the following reasons. (a). the strut may not be perfectly straight initially.

(b). the load may not be applied exactly along the axis of the Strut.

(c). one part of the material may yield in compression more readily than others owing to some lack of uniformity in the material properties through out the strut.

In all the problems considered so far we have assumed that the deformation to be both progressive with increasing load and simple in form i.e. we assumed that a member in simple tension or compression becomes progressively longer or shorter but remains straight. Under some circumstances however, our assumptions of progressive and simple deformation may no longer hold good and the member become unstable. The term strut and column are widely used, often interchangeably in the context of buckling of slender members.]

At values of load below the buckling load a strut will be in stable equilibrium where the displacement caused by any lateral disturbance will be totally recovered when the disturbance is removed. At the buckling load the strut is said to be in a state of neutral equilibrium, and theoretically it should than be possible to gently deflect the strut into a simple sine wave provided that the amplitude of wave is kept small.

Theoretically, it is possible for struts to achieve a condition of unstable equilibrium with loads exceeding the buckling load, any slight lateral disturbance then causing failure by buckling, this condition is never achieved in practice under static load conditions. Buckling occurs immediately at the point where the buckling load is reached, owing to the reasons stated earlier.

The resistance of any member to bending is determined by its flexural rigidity  $EI$  and is The quantity  $I$  may be written as  $I = Ak^2$ ,

Where  $I$  = area of moment of inertia  $A$  =  
area of the cross-section

$k$  = radius of gyration.

The load per unit area which the member can withstand is therefore related to  $k$ . There will be two principal moments of inertia, if the least of these is taken then the ratio



It is called the slenderness ratio. Its numerical value indicates whether the member falls into the class

Further, we know that

$$\frac{l}{k} \text{ i.e. } \frac{\text{length of member}}{\text{least radius of gyration}}$$

$$EI \frac{d^2 y}{dx^2} = M$$

of columns or struts.

$$EI \frac{d^2 y}{dx^2} = -P \cdot y = M$$

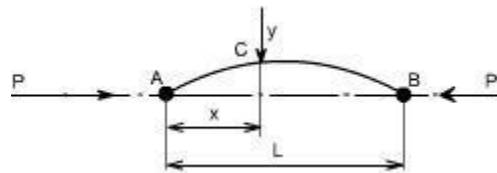
**Euler's Theory :** The struts which fail by buckling can be analyzed by Euler's theory. In the following sections, different cases of the struts have been analyzed.

**Case A: Strut with pinned ends:**

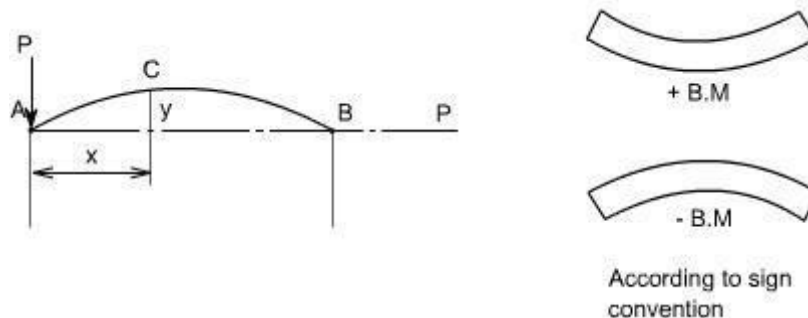
Consider an axially loaded strut, shown below, and is subjected to an axial load „P' this load „P' produces a deflection „y' at a distance „x' from one end.

Assume that the ends are either pin jointed or rounded so that there is no moment at either end.

**Assumption:**



The strut is assumed to be initially straight, the end load being applied axially through centroid.



In this equation „M' is not a function „x'. Therefore this equation can not be integrated directly as has been done in the case of deflection of beams by integration method.

Thus,

$$EI \frac{d^2 y}{dx^2} + P y = 0$$

Though this equation is in „y' but we can't say at this stage where the deflection would be maximum or minimum.

So the above differential equation can be arranged in the following

$$\text{form } \frac{d^2 y}{dx^2} + \frac{P y}{EI} = 0$$

Let us define a operator  $D =$

$d/dx$

$$(D^2 + n^2) y = 0 \text{ where } n^2 = P/EI$$

This is a second order differential equation which has a solution of the form consisting of complimentary function and particular integral but for the time being we are interested in the complementary solution only [in this P.I = 0; since the R.H.S of Diff. equation = 0] Thus  $y = A \cos (nx) + B \sin (nx)$  Where A and B are some constants.

Therefore  $y = A \cos \sqrt{\frac{P}{EI}} x + B \sin \sqrt{\frac{P}{EI}} x$

In order to evaluate the constants A and B let us apply the boundary conditions,

- (i) at  $x = 0; y = 0$
- (ii) at  $x = L ; y = 0$

Applying the first boundary condition yields  $A = 0$ .  
Applying the second boundary condition gives

$$B \sin \left( L \sqrt{\frac{P}{EI}} \right) = 0$$

Thus either  $B = 0$ , or  $\sin \left( L \sqrt{\frac{P}{EI}} \right) = 0$

if  $B=0$ , that  $y=0$  for all values of  $x$  hence the strut has not buckled yet. Therefore, the solution required is

$$\sin \left( L \sqrt{\frac{P}{EI}} \right) = 0 \text{ or } \left( L \sqrt{\frac{P}{EI}} \right) = \pi \text{ or } nL = \pi$$

$$\text{or } \sqrt{\frac{P}{EI}} = \frac{\pi}{L} \text{ or } P = \frac{\pi^2 EI}{L^2}$$

From the above relationship the least value of P which will cause the strut to buckle, and it is called the “**Euler Crippling Load**”  $P_e$  from which we obtain.

$$P_e = \frac{\pi^2 EI}{L^2}$$

It may be noted that the value of I used in this expression is the least moment of inertia

It should be noted that the other solutions exists for the equation

$$\sin \left( L \sqrt{\frac{P}{EI}} \right) = 0 \quad \text{i.e. } \sin nL = 0$$

The interpretation of the above analysis is that for all the values of the load P, other than those which make  $\sin nL = 0$ ; the strut will remain perfectly straight since  $y = B \sin nL = 0$

For the particular value of

$$P_e = \frac{\pi^2 EI}{L^2}$$

$$\sin nL = 0 \text{ or } nL = \pi$$

$$\text{Therefore } n = \frac{\pi}{L}$$

$$\text{Hence } y = B \sin nx = B \sin \frac{\pi x}{L}$$

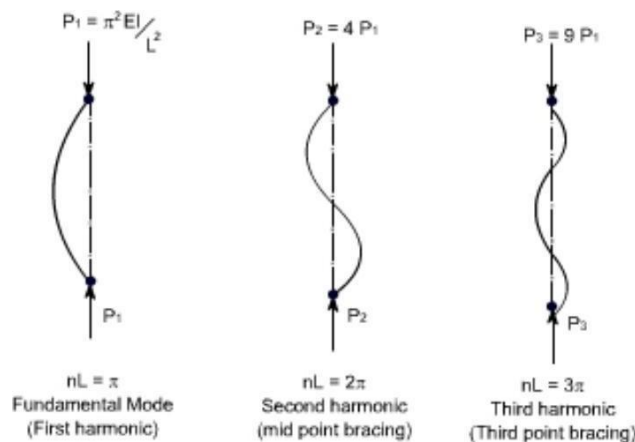
Then we say that the strut is in a state of neutral equilibrium, and theoretically any deflection which it suffers will be maintained. This is subjected to the limitation that „L' remains sensibly constant and in practice slight increase in load at the critical value will cause the deflection to increase appreciably until the material fails by yielding.

Further it should be noted that the deflection is not proportional to load, and this applies to all strut problems; like wise it will be found that the maximum stress is not proportional to load. The solution chosen of  $nL = \pi$  is just one particular solution; the solutions  $nL = 2\pi, 3\pi, 5\pi$  etc are equally valid mathematically and they do, in fact, produce values of

„ $P_e$ ' which are equally valid for modes of buckling of strut different from that of a simple bow. Theoretically therefore, there are an infinite number of values of  $P_e$ , each corresponding with a different mode of buckling.

The value selected above is so called the fundamental mode value and is the lowest critical load producing the single bow buckling condition.

The solution  $nL = 2\pi$  produces buckling in two half – waves,  $3\pi$  in three half-waves etc.



$$L\sqrt{\frac{P}{EI}} = \pi \text{ or } P_1 = \frac{\pi^2 EI}{L^2}$$

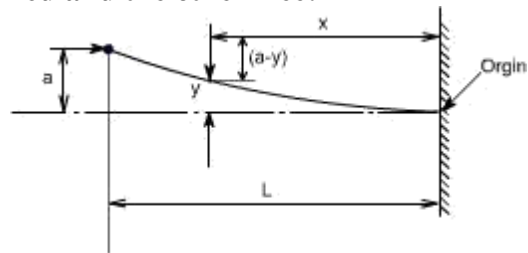
$$\text{If } L\sqrt{\frac{P}{EI}} = 2\pi \text{ or } P_2 = \frac{4\pi^2 EI}{L^2} = 4P_1$$

$$\text{If } L\sqrt{\frac{P}{EI}} = 3\pi \text{ or } P_3 = \frac{9\pi^2 EI}{L^2} = 9P_1$$

If load is applied sufficiently quickly to the strut, then it is possible to pass through the fundamental mode and to achieve at least one of the other modes which are theoretically possible. In practical loading situations, however, this is rarely achieved since the high stress associated with the first critical condition generally ensures immediate collapse.

**struts and columns with other end conditions:** Let us consider the struts and columns having different end conditions

**Case b: One end fixed and the other free:**



writing down the value of bending moment at the point C

$$B. M|_C = P(a - y)$$

Hence, the differential equation becomes,

$$EI \frac{d^2 y}{dx^2} = P(a - y)$$

On rearranging we get

$$\frac{d^2 y}{dx^2} + \frac{Py}{EI} = \frac{Pa}{EI}$$

$$\text{Let } \frac{P}{EI} = n^2$$

Hence in operator form, the differential equation reduces to  $(D^2 + n^2) y = n^2 a$

The solution of the above equation would consist of complementary solution and particular solution, therefore

$$y_{gen} = A \cos(nx) + \sin(nx) + P. I$$

where

P.I = the P.I is a particular value of y which satisfies the differential equation

Hence  $y_{P.I} = a$  Therefore the complete solution becomes  $Y = A$

$$\cos(nx) + B \sin(nx) + a$$

Now imposing the boundary conditions to evaluate the constants A and B

(i) at  $x = 0; y = 0$

This yields  $A = -a$

(ii) at  $x = 0; dy/dx = 0$

This yields  $B = 0$  Hence

$$y = -a \cos(nx) + a$$

Further, at  $x = L; y = a$

$$\text{Therefore } a = -a \cos(nL) + a$$

$$\text{or } 0 = \cos(nL)$$

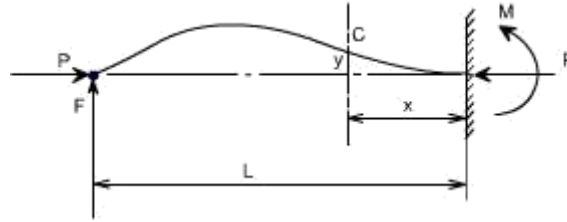
Hence the least solution would be

$$nL = 2\pi$$

Now the fundamental mode of buckling in this case would be

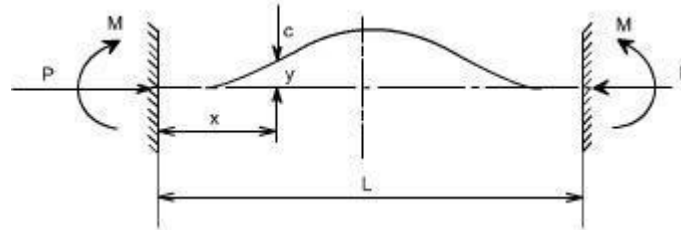
$$\sqrt{\frac{P}{EI}} L = \frac{\pi}{2}, \text{ Therefore, the Euler's crippling load is given as}$$

$$P_e = \frac{\pi^2 EI}{4L^2}$$



### Case 3

#### Strut with fixed ends:



Due to the fixed end supports bending moment would also appears at the supports, since this is the property of the support.

Bending Moment at point C =  $M - P.y$

#### One end fixed, the other pinned

In order to maintain the pin-joint on the horizontal axis of the unloaded strut, it is necessary in this case to introduce a vertical load F at the pin. The moment of F about the built in end then balances the fixing moment.

With the origin at the built in end, the B,M at C is given as

$$EI \frac{d^2 y}{dx^2} = -Py + F(L - x)$$

$$EI \frac{d^2 y}{dx^2} + Py = F(L - x)$$

Hence

$$\frac{d^2 y}{dx^2} + \frac{P}{EI} y = \frac{F}{EI} (L - x)$$

In the operator form the equation reduces to

$$(D^2 + n^2) y = \frac{F}{EI} (L - x)$$

$$y_{\text{particular}} = \frac{F}{n^2 EI} (L - x) \text{ or } y = \frac{F}{P} (L - x)$$

The full solution is therefore

$$y = A \cos nx + B \sin nx + \frac{F}{P} (L - x)$$

The boundary conditions relevant to the problem are at  $x=0; y=0$

$$\text{Hence } A = -\frac{FL}{P}$$

$$\text{Also at } x=0; \frac{dy}{dx} = 0$$

$$\text{Hence } B = \frac{F}{nP}$$

$$\text{or } y = -\frac{FL}{P} \cos nx + \frac{F}{nP} \sin nx + \frac{F}{P} (L - x)$$

$$y = \frac{F}{nP} [\sin nx - nL \cos nx + n(L - x)]$$

Also when  $x = L ; y = 0$

Therefore

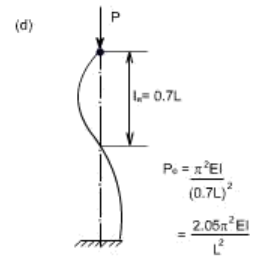
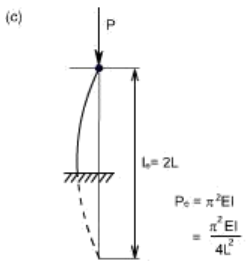
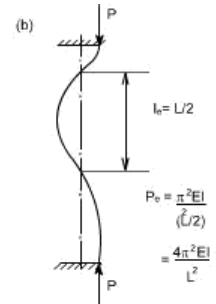
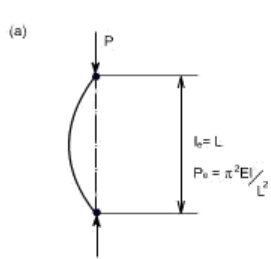
$$nL \cos nL = \sin nL$$

The lowest value of  $nL$  ( neglecting zero) which satisfies this condition and which therefore produces the fundamental buckling condition is  $nL = 4.49$  radian

$$\text{or } \sqrt{\frac{P}{EI}} L = 4.49$$

$$\frac{P_e L^2}{EI} = 20.2$$

$$P_e = \frac{2.05 \pi^2 EI}{L^2}$$



**Equivalent Strut Length:**

$$\text{Euler's stress, } \sigma_e = \frac{P_e}{A} = \frac{\pi^2 EI}{Al^2}$$

Having derived the results for the buckling load of a strut with pinned ends the Euler loads for other end conditions may all be written in the same form.

$$\text{i.e. } P_e = \frac{\pi^2 EI}{L^2}$$

$$\text{But, } l = Ak^2$$

$$\left(\frac{l}{k}\right)^2$$

Where L is the equivalent length of the strut and can be related to the actual length of the strut depending on the end conditions.

The equivalent length is found to be the length of a simple bow (half sine wave) in each of the strut deflection curves shown. The buckling load for each end condition shown is then readily obtained. The use of equivalent length is not restricted to the Euler's theory and it will be used in other derivations later.

The critical load for columns with other end conditions can be expressed in terms of the critical load for a hinged column, which is taken as a fundamental case.

For case (c) see the figure, the column or strut has inflection points at quarter points of its unsupported length. Since the bending moment is zero at a point of inflection, the freebody diagram would indicate that the middle half of the fixed ended is equivalent to a hinged column having an effective length  $L_e = L / 2$ .

The four different cases which we have considered so far are:

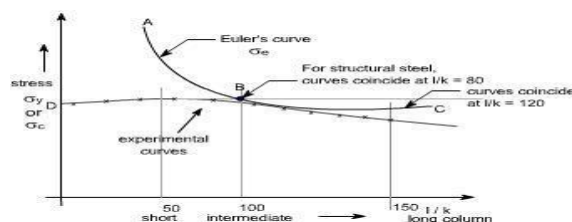
- (a) Both ends pinned
- (b) Both ends fixed
- (c) One end fixed, other free
- (d) One end fixed and other pinned

**Limitations of Euler's Theory :**

In practice the ideal conditions are never [ i.e. the strut is initially straight and the end load being applied axially through centroid] reached. There is always some eccentricity and initial curvature present. These factors need to be accommodated in the required formula's.

It is realized that, due to the above mentioned imperfections the strut will suffer a deflection which increases with load and consequently a bending moment is introduced which causes failure before the Euler's load is reached. In fact failure is by stress rather than by buckling and the deviation from the Euler value is more marked as the slenderness-ratio  $l/k$  is reduced. For values of  $l/k < 120$  approx, the error in applying the Euler theory is too great to allow of its use. The stress to cause buckling from the Euler formula for the pin ended strut is

A plot of  $\sigma_e$  versus  $l/k$  ratio is shown by the curve ABC.



Allowing for the imperfections of loading and strut, actual values at failure must lie within and below line CBD.

Other formulae have therefore been derived to attempt to obtain closer agreement between the actual failing load and the predicted value in this particular range of slenderness ratio i.e.  $l/k=40$  to  $l/k=100$ .

**(a) Straight – line formulae :**

The permissible load is given by the formulae

$$P = \sigma_y A \left[ 1 - n \left( \frac{l}{k} \right) \right]$$

Where the value of index „n' depends on the material used and the end conditions.

**(b) Johnson parabolic formulae :** The Johnson parabolic formulae is defined as

$$P = \sigma_y A \left[ 1 - b \left( \frac{l}{k} \right)^2 \right]$$

where the value of index „b' depends on the end conditions.

**(c) Rankine Gordon Formulae :**

$$\frac{1}{P_R} = \frac{1}{P_e} + \frac{1}{P_c}$$

Where  $P_e$  = Euler crippling load

$P_c$  = Crushing load or Yield point load in Compression

$P_R$  = Actual load to cause failure or Rankine load

Since the Rankine formulae is a combination of the Euler and crushing load for a strut.

For a very short strut  $P_e$  is very large hence  $1/P_e$  would be large so that  $1/P_e$  can be neglected.

$$\frac{1}{P_R} = \frac{1}{P_e} + \frac{1}{P_c}$$

Thus  $P_R = P_c$ , for very large struts,  $P_e$  is very small so  $1/P_e$  would be large and  $1/P_c$  can be neglected, hence  $P_R = P_e$

The Rankine formulae is therefore valid for extreme values of  $l/k$ . It is also found to be fairly accurate for the intermediate values in the range under consideration. Thus rewriting the formula in terms of stresses, we have

$$a = \frac{\sigma_y}{\pi^2 EI}$$

$$\begin{aligned} \frac{1}{\sigma A} &= \frac{1}{\sigma_e A} + \frac{1}{\sigma_y A} \\ \frac{1}{\sigma} &= \frac{1}{\sigma_e} + \frac{1}{\sigma_y} \\ \frac{1}{\sigma} &= \frac{\sigma_e + \sigma_y}{\sigma_e \cdot \sigma_y} \\ \sigma &= \frac{\sigma_e \cdot \sigma_y}{\sigma_e + \sigma_y} = \frac{\sigma_y}{1 + \frac{\sigma_y}{\sigma_e}} \end{aligned}$$

For struts with both ends pinned

$$\begin{aligned} \sigma_e &= \frac{\pi^2 E}{\left( \frac{l}{k} \right)^2} \\ \sigma &= \frac{\sigma_y}{1 + \frac{\sigma_y}{\pi^2 E} \left( \frac{l}{k} \right)^2} \\ \sigma &= \frac{\sigma_y}{1 + a \left( \frac{l}{k} \right)^2} \end{aligned}$$



Where and the value of „a' is found by conducting experiments on various materials. Theoretically, but having a value normally found by experiment for various materials. This will take into account other types of end conditions.