

LECTURES NOTES
ON
ANALOG ELECTRONICS & OP-AMP

BY

Er. Jadunath murmu, Sr. lect E&tc Engg.

GOVT.POLYTECHNIC,NAYAGARH

P-N JUNCTION DIODE

1 . 1 P-N Junction Diode

When a p-type semiconductor is suitably joined with n-type semiconductor, the contact surface is called p-n junction

A p-n junction diode is two-terminal or two-electrode semiconductor device, which allows the electric current in only one direction while blocks the electric current in opposite or reverse direction. If the diode is forward biased, it allows the electric current flow. On the other hand, if the diode is reverse biased, it blocks the electric current flow. P-N junction semiconductor diode is also called as p-n junction semiconductor device.

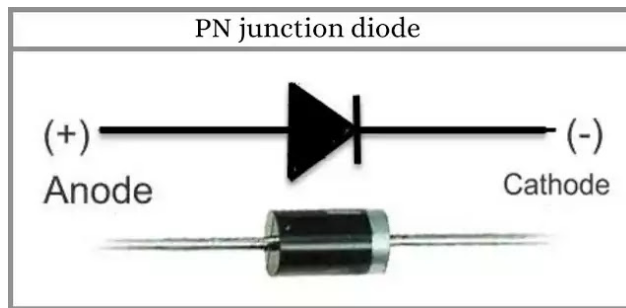

Symbol of PN junction diode

In the above figure, arrowhead of a diode indicates the conventional direction of electric current.

1 . 2 Working of Diode

Diode working in two biased condition

- i) Forward bias
- ii) Reverse Bias

Forward Bias

When an external voltage is applied to P-N junction in such a direction that it cancels the potential barrier and permits the current flow is called forward bias.

The p-n junction is said to be forward-biased when the p-type is connected to the positive terminal of the battery and the n-type to the negative terminal. The built-in electric field at the

p-n junction and the applied electric field are in opposing directions (against potential barrier) when the p-n junction is forward biased so potential barrier is reduced. As potential barrier is very small i.e 0.3 Volt for Ge and 0.7 volt for Si. Therefore a small forward voltage is sufficient to eliminate the barrier , so junction resistance becomes almost Zero.

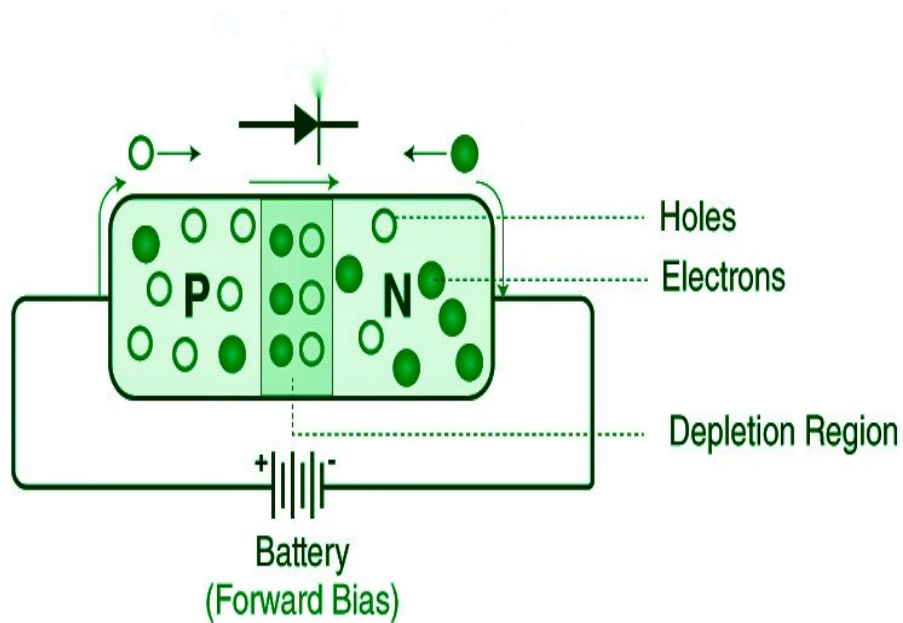

Following point are to be noted

- i. Depletion layer is minimum
- ii. Junction offer low resistance
- iii. Flow of current is maximum
- iv. Diode act as close switch

Reverse Bias

When an external voltage is applied to P-N junction in such a direction that it increase the potential barrier and then it is called as reverse bias

The p-n junction is said to be reverse-biased when the p-type is linked to the negative terminal of the battery and the n-type is attached to the positive side. The applied electric field and the built-in electric field are both in the same direction in this situation.

The resultant electric field is in the same direction as the built-in electric field, resulting in a more resistive, thicker depletion zone. If the applied voltage is increased, the depletion area gets more resistant and thicker.

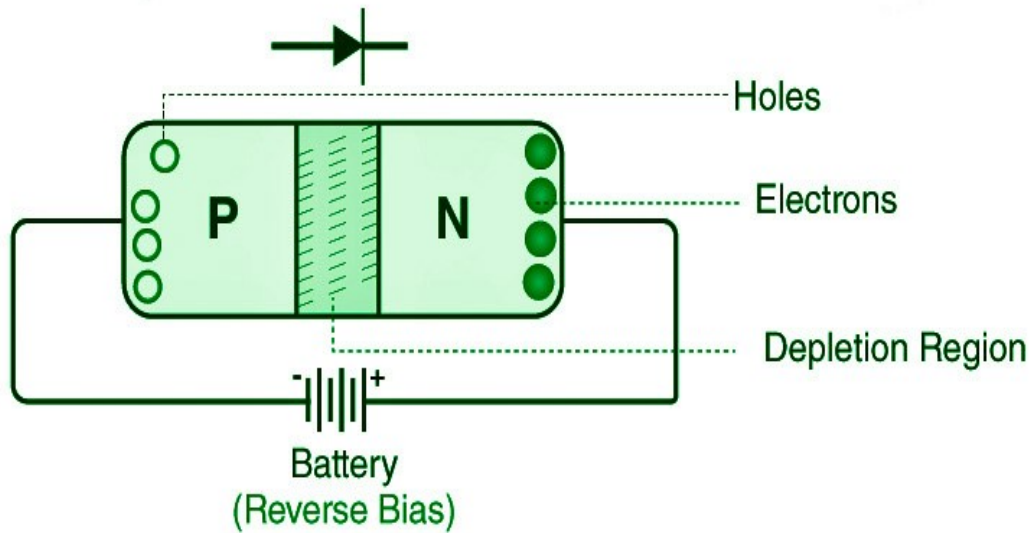

Following point are to be noted

- i. Depletion layer is maximum
- ii. Junction offer high resistance
- iii. Flow of current is zero
- iv. Diode act as open switch

Application of Diode

- i. Rectifiers
- ii. Clipper Circuits
- iii. Clamping Circuits
- iv. Reverse Current Protection Circuits

1.3 V-I characteristic of PN junction Diode.

VI characteristics of PN junction diodes is a curve between the voltage across the junction and current through the circuit. Voltage is taken along the x-axis while the current is taken along the y-axis.

Circuit arrangement for determining the V-I characteristics of P-N junction is known shown in fig-1

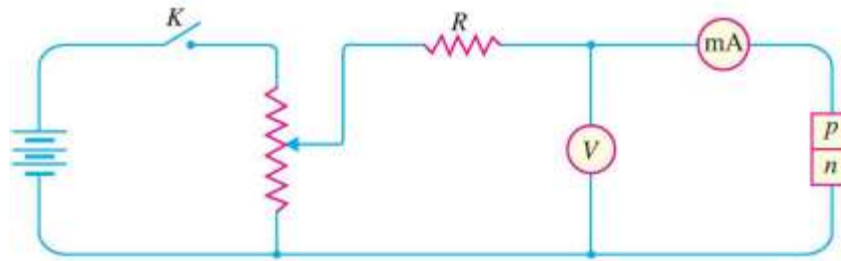

Fig-1

The V-I characteristics curve of the p-n junction diode is shown in the graph shown in fig 2. With the help of the curve, we can see that the diode works in three different areas, which are:

- i) Zero external voltage.
- ii) Forward bias
- iii) Reverse bias

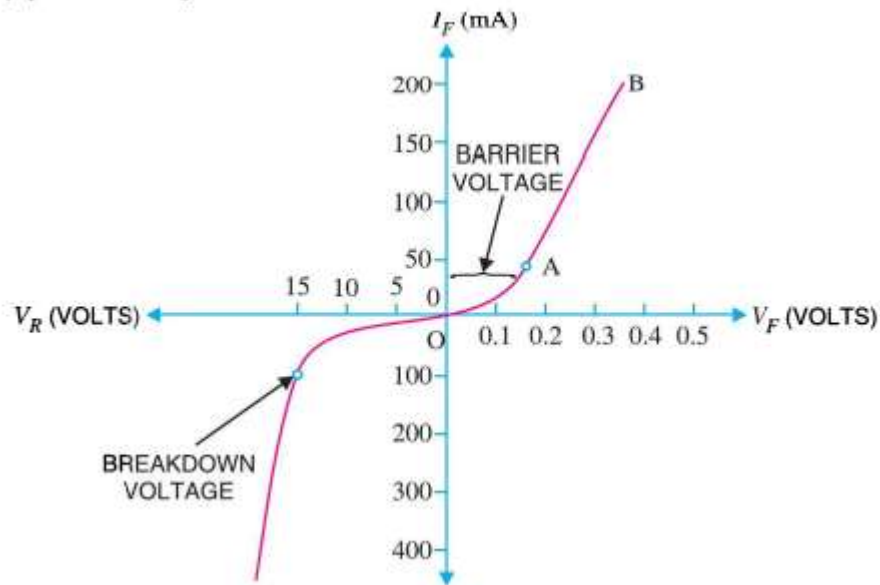

Fig-2

i) Zero external voltage.

When the external voltage is zero, i.e. circuit is open at K, the potential barrier at junction does not permit current flow. Therefore, the circuit current is zero as indicating O in fig.1

ii) Forward bias

When the p-n junction diode is in forwarding bias, the p-type is linked to the positive terminal of the external voltage, while the n-type is connected to the negative terminal. The potential barrier is reduced. At some forward voltage (0.7 V for silicon diodes and 0.3 V for germanium diodes) the potential barriers is altogether eliminated and current starts flowing in the circuit.

From now onwards, the current increases with the increase in forward voltage. Thus a rising curve OB is obtained with forward bias shown in fig-2. From the forward characteristics it seen that at first region OA, the current increases very slowly and curve is non-linear. Because the voltage supplied to the diode overcomes the potential barrier. However, once the external voltage exceed the potential barrier voltage, the pn junction behaves like an ordinary conductor and current rises very sharply with increase in external voltage shown in curve AB which is linear.

iii) Reverse bias

When the PN junction diode is under Reverse bias, the p-type is linked to the negative terminal of the external voltage, while the n-type is connected to the positive terminal. As a result, the potential barrier at the junction increases. So the junction resistance becomes very high and practically no current flows through the circuit.

Very small current (i.e. some micro ampere) flows in the circuit due to minority charge carriers. When the applied voltage is raised, the kinetic energy of the minority charges increases, it become enough to knock out electrons from the semiconductor atoms. At this stage break down of the junction occurs and sudden rise of reverse current and fall down the resistance of barrier this may destroy the junction permanently.

Important Terms

- i) *Breakdown voltage.* It is the minimum reverse voltage at which pn junction breakdown which sudden rise in reverse current.

- ii) *Ideal diode* . An ideal diode is one which behaves as a perfect conductor (Resistance=0) when forward biased and as a perfect insulator (Resistance= ∞) when reverse biased

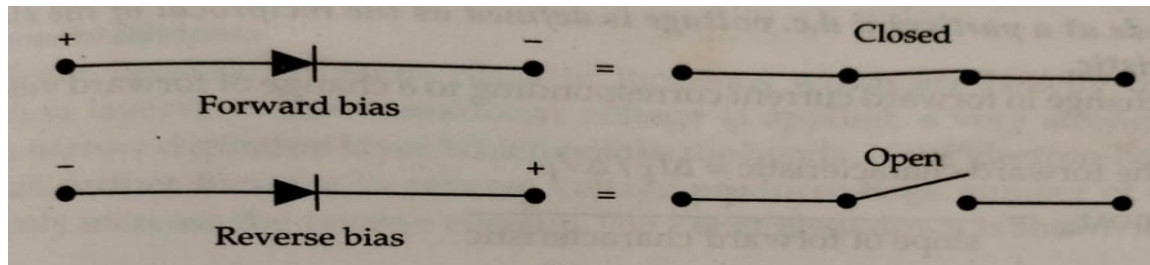

Fig.1

- iii) *Knee voltage*. It is the forward voltage at which the current through the junction starts to increase rapidly.

1 . 4 DC load line

Consider a crystal diode connected in series with a load resistance R_L across a supply voltage V_S shown in fig-1. Here the diode is forward biased. A line drawn on the characteristics of the device that represents all d.c. conditions that could exist within the circuit for given values of V_S and R_L is called as DC load line.

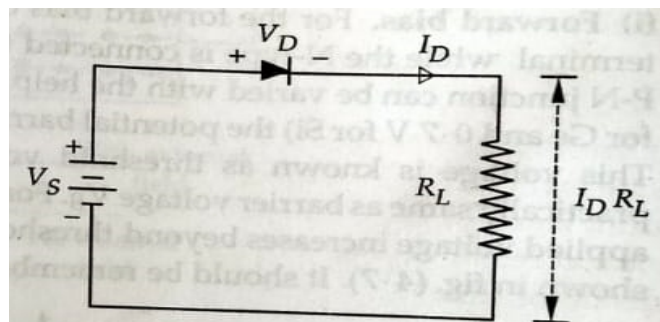

Fig.1

Applying Kirchhoff's voltage law to the diode circuit,

$$V_S - V_D - I_D R_L = 0$$

$$\text{Or } I_D = V_S / R_L - V_D / R_L$$

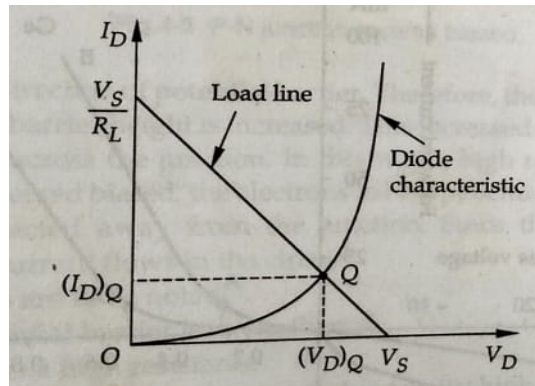

Fig.2

This represents a straight line

So d.c. load line is straight line

From the above equation, when $V_D=0$, then $I_D=(V_S/R_L)$

When $I_D=0$, then $V_D=V_S$

A line passing through the point (V_S/R_L) and V_S is called a dc load line

Quiescent point (Q-point)

The points where the characteristic curve and the load line intersect are the possible operating point(s) (Q points) of the circuit; at these points the current and voltage parameters are compatible with circuit condition

Importance of dc load line

- The DC load line analysis main intention is to find the Quiescent Point (Q – point)
- Another way of expressing a Q point is by addressing it as biasing. Biasing in electronics means establishing predetermined voltages or currents at various points of an electronic circuit to promote proper operating conditions in electronic components.
- The linear analysis of the circuit is obtained for the non-linear devices like diode or transistors by using this concept.
- The main intention behind the analysis of the load line is to find the operating point referred to as the quiescent point (Q-point).
- The Q-points formed by the dc load line are the centers at which the voltage and current parameters equivalent to each other for both the parts of the circuit.

- From this, the operating point obtained is essential while drawing the ac load lines.
- If the resistance is constant and the dc voltage applied to the circuit varies. The load line concept is significant for analyzing the circuit in an efficient manner.

1 . 6 Junctions break down.

It is the minimum reverse voltage at which p-n junction breaks down which sudden rise in reverse current. The breakdown voltage depends upon the width of the depletion region (doping level). Depending upon the doping level, it is two type

- Zener breakdown.** The Zener breakdown takes place in the junctions which are heavily doped(having narrow depletion layers). When breakdown voltage is applied, a very strong electric field appears across narrow depletion layer which break the bonds & electron-hole pairs are generated. A small further increase in reverse voltage produces large number of current carriers which suddenly increase the reverse current
- Avalanche breakdown.** The **avalanche** breakdown takes place in the junctions which are lightly doped(having wide depletion layers) and the electric field across the junction is not so strong to produce zener breakdown. Even at room temperature some minority carriers are produce in depletion layer with reverse bias , the electrons move towards positive terminal of battery. At large reverse voltage, they gain enough kinetic energy to free the valence electron from semiconductor atoms. The newly liberated electrons in turn free other valence electrons. In this way process leads to anavalanche (flood) of carriers and consequently a very low reverse resistance. So pn junction conduct very large reverse current.

Differences Between Zener Breakdown and Avalanche Breakdown

Zener Breakdown

- The reason here behind this breakdown is due to the high intensity of the electric field.
- The width of the region of depletion is thin.
- The concentration level of doping is high at the junction.
- Mainly the production of electrons focused here.
- The intensity of the electric field is strong enough.
- The coefficient of temperature is of negative value.
- The ionization in this breakdown is due to the strong intensity of the electric field.
- The breakdown voltage and the temperature are inversely related to each other.
- The occurrence of breakdown doesn't affect the voltage.
- As the reverse voltage is removed from the diode the junction gets back to its normal position.

Avalanche Breakdown

- The reason behind the occurrence of this breakdown is mainly due to the collision that takes place between the carriers.
- The region of the depletion region is thick enough.
- The concentration of doping at the junction is at the minimum.
- Focused on the production of a pair of electrons and holes.
- The intensity of the electric field is low.
- The coefficient of temperature is of positive value.
- The ionization that occurred here is due to the influence of the collision effect.
- The breakdown voltage and the temperature are directly related to each other.
- Once the breakdown has occurred the voltage tends to vary.
- Once it undergoes the breakdown the junction gets destroyed completely it cannot retain back its position

1.7 P-N Diode clipping Circuit.

P-N Diode clipping Circuit is wave shaping circuit, which can control the shape of the output waveform by eliminating or clipping or remove a part (some portion) of applied wave. This is done without distorting the other (remaining) part of waveform.

Classification of Clipping Circuit

1. Positive clippers.
2. Negative clippers.

3. Biased clippers Positive clippers.
4. Biased clippers Negative clippers.
5. Combination clippers.

1. Positive clippers.

The clipper which removes the positive half cycle of input voltage
 It actually removes the positive half cycles of the input voltage.

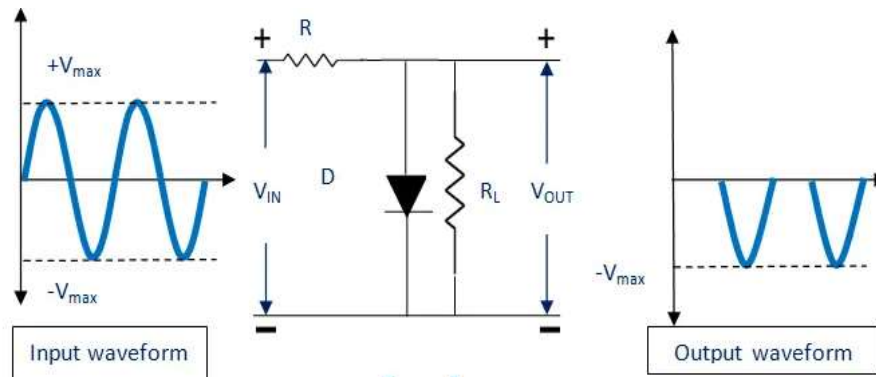

- Here the diode is kept in parallel with the load
- During the positive half cycle of input wave the diode D is forward biased and act close switch this causes the diode conduct current heavily
- The voltage across the diode or across the load R_L is zero so out voltage during positive half cycle is zero.
- During the negative half cycle of input wave the diode D is reverse biased and diode behaves open switch this causes the diode conduct current does not flow, consequence the entire input voltage appear across the diode or across the load resistor R_L , if R is much smaller than R
- Hence out put voltage $= \frac{R_L}{R+R_L} V_m = -V_m$

2. Negative clippers.

The clipper which removes the negative half cycle of input voltage
 It actually removes the negative half cycles of the input voltage.

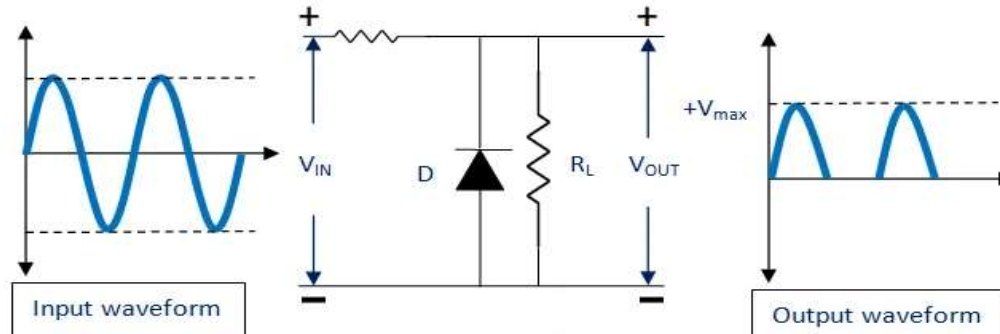

- Here the diode is kept in parallel with the load
- During the positive half cycle of input cycle the diode D is reverse biased and act open switch this causes the diode conduct current does not flow, consequence the entire input voltage appear across the diode or across the load resistor R_L , if R is much smaller than R_L
- Hence out put voltage $= \frac{R_L}{R+R_L} V_m = V_m$
- During the negative half cycle of input wave the diode D is forward biased and diode behaves close switch this causes the diode conduct current heavily.
- The voltage across the diode or across the load R_L is zero so out voltage during negative half cycle is zero.

3. Biased clippers Positive clippers.

4. RECTIFIER CIRCUITS & FILTERS

Rectifier

Rectifier is Electronics device which conversion of alternating current (AC) to direct current (DC).

3.1 Classification of rectifiers

Rectifiers may be classified in to two categories depending upon the period of conduction. They are

- (a) Half-wave rectifiers
- (b) Full-wave rectifiers

Full wave rectifiers may further be classified in to two categories depending upon nature of the circuit connection. They are

- (a) Centre tapped full-wave rectifier
- (b) Bridge full-wave rectifier

Half wave rectifier

A half wave rectifier circuit is one which conducts current only during the positive half cycles of input a.c. supply. The negative half cycles of a.c. supply are suppressed i.e. during negative half cycles, no current is conducted and hence no voltage appears across the load. Therefore current always flows in one direction through the load.

Working

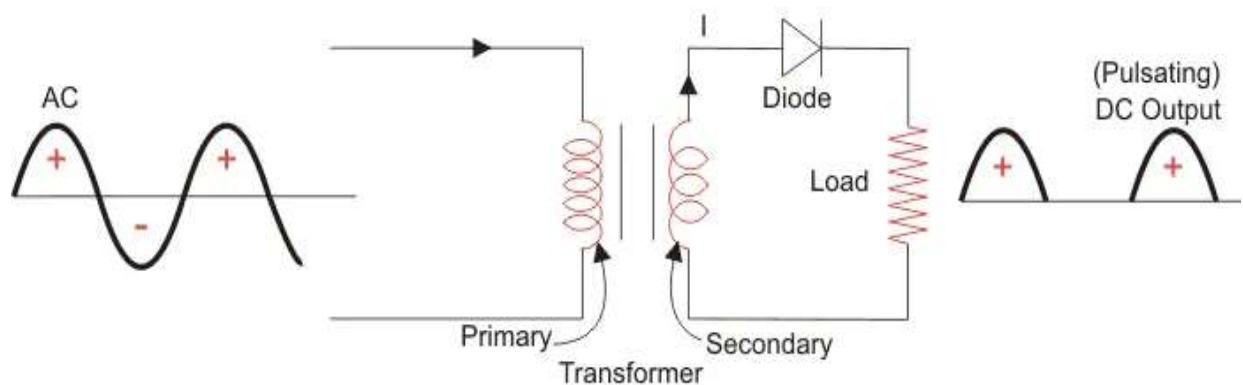

First, a high AC voltage is applied to the primary side of the step-down transformer and we will get a low voltage at the secondary winding which will be applied to the diode.

During the positive half cycle of the AC voltage, the diode will be forward biased and the current flows through the diode.

During the negative half cycle of the AC voltage, the diode will be reverse biased and the flow of current will be blocked. The final output voltage waveform on the secondary side (DC) is shown in figure above.

Advantages of half-wave rectifier:

- Half wave rectifier is a simple circuit.
- It has a low cost.
- We can easily use it.
- We can easily construct.
- It has a low number of components, therefore it is cheap.

Disadvantages of half-wave rectifier:

- The transformer utilization factor is low.
- They produce a low output voltage.
- DC saturation of transformer core resulting in magnetizing current and also some hysteresis losses and generation of harmonics.
- The power output and therefore rectification efficiency are quite low. This is due to the fact that power is delivered only during the one-half cycle of the input alternating voltage.
- Ripple factor is high and elaborate filtering is, therefore required to give steady dc output.
- They only allow a half cycle through per sine wave, and the other half cycle is wasted. This leads to power loss.

Analysis

3.2.1 DC output current and voltage

Full wave rectifier

In full wave rectifier, current flows through the load in the same direction for both half cycles of input a.c. voltage. The commonly used full wave rectifier circuits are

- (1) Centre tap full wave rectifier (2) full wave bridge rectifier.

Centre tapped full wave rectifier

The circuit employs two diodes and a Centre tapped secondary winding is used with two diodes connected so that each uses one half cycle of input a.c. voltage. In other words the first diode utilizes the a.c voltage appearing across the upper half of secondary winding for rectification, while the second diode uses the lower half winding.

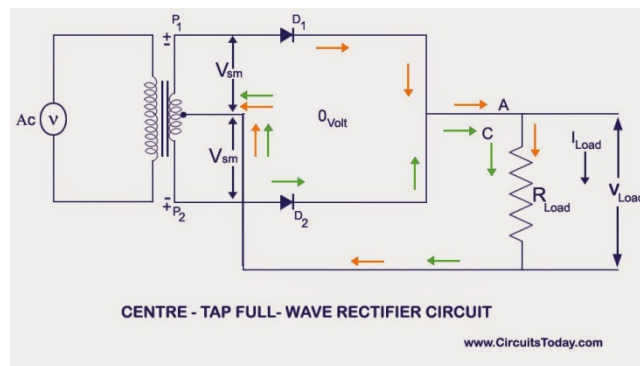

Disadvantages of Centre tapped full wave rectifier

1. It is difficult to locate the Centre tap on the secondary winding.
2. The d.c output is small as each diode utilizes only one half of the transformer secondary voltage.
3. The diodes used must have high peak inverse voltage.

Full wave bridge rectifier

Full wave operation can be obtained even without the Centre tapped transformer in bridge rectifier. It contains four diodes connected to form a bridge.

Alternating voltage is applied to the diagonally opposite ends of the bridge through the transformer. Between other ends of the bridge the load resistance is connected through the load.

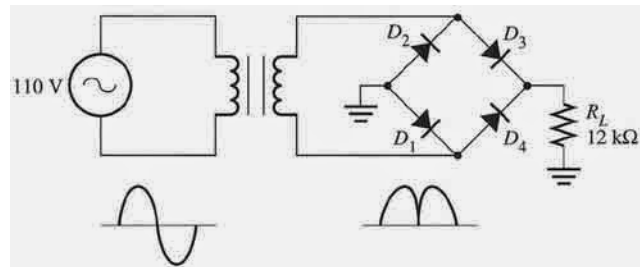

Advantages and disadvantages of bridge rectifier

The following are advantages

1. No centre tap is needed in the transformer secondary.
2. The output is twice that of the centre tap circuit for the same secondary voltage.
3. The peak inverse voltage is one half that of the centre tap circuit.

The following are disadvantages

1. It requires four diodes.
2. As during each half cycle of a.c input two diodes that conduct are in series, therefore voltage drop in the internal resistance of the rectifying unit will be twice. This is objectionable when secondary voltage is small.

3.2.4 Ripple factor

3.2.4. Ripple Factor:-

The ripple factor measures the percentage of ac component in the ripple free rectifier output.

$$r = \frac{\text{r.m.s value of A.C Component of output.}}{\text{Average value of o/p}}$$

$$= \frac{I_{ac, rms}}{I_{d.c}}$$

output current (I) of rectifier contains both ac component (I_{ac}) and d.c component $I_{d.c}$

$$I = I_{ac} + I_{d.c}$$

$$\Rightarrow I_{ac} = I - I_{d.c}$$

$$I_{ac, rms} = \sqrt{\int_0^{2\pi} \frac{I_{ac}^2}{2\pi} d\theta}$$

$$= \left[\frac{1}{2\pi} \int_0^{2\pi} I_{ac}^2 d\theta \right]^{1/2}$$

$$= \left[\frac{1}{2\pi} \int_0^{2\pi} (I - I_{d.c})^2 d\theta \right]^{1/2}$$

$$= \left[\frac{1}{2\pi} \int_0^{2\pi} (I^2 + I_{d.c}^2 - 2II_{d.c}) d\theta \right]^{1/2}$$

$$= \left[\frac{1}{2\pi} \int_0^{2\pi} I^2 d\theta + \frac{1}{2\pi} \int_0^{2\pi} I_{d.c}^2 d\theta - \frac{1}{2\pi} \int_0^{2\pi} 2II_{d.c} d\theta \right]^{1/2}$$

$$= \left[\frac{1}{2\pi} \int_0^{2\pi} I^2 d\theta + \frac{I_{d.c}^2}{2\pi} \int_0^{2\pi} d\theta - \frac{2I_{d.c}}{2\pi} \int_0^{2\pi} I d\theta \right]^{1/2}$$

$$= \left[I_{rms}^2 + \frac{I_{dc}^2}{2\pi} \int_0^{2\pi} d\theta - \frac{2I_{dc}}{2\pi} \int_0^{2\pi} I d\theta \right]^{1/2}$$

$$\text{as } I_{rms} = \sqrt{\frac{1}{2\pi} \int_0^{2\pi} I^2 d\theta}$$

$I_{dc} = \text{D.C. current is constant.}$

$$= \left[I_{r.m.s}^2 + \frac{I_{dc}^2}{2\pi} [0]_0^{2\pi} - \frac{2I_{dc}}{2\pi} \int_0^{2\pi} I d\theta \right]^{1/2}$$

$$= \left[I_{r.m.s}^2 + \frac{I_{dc}^2}{2\pi} [2\pi - 0] - 2I_{dc} \times \frac{1}{2\pi} \int_0^{2\pi} I d\theta \right]^{1/2}$$

$$= \left[I_{r.m.s}^2 + \frac{I_{dc}^2}{2\pi} \times 2\pi - 2I_{dc} \times I_{dc} \right]^{1/2}$$

$$\text{as } I_{dc} = \frac{1}{2\pi} \int_0^{2\pi} I d\theta$$

$$= \left[I_{r.m.s}^2 + I_{dc}^2 - 2I_{dc}^2 \right]^{1/2}$$

$$= \left[I_{r.m.s}^2 - I_{dc}^2 \right]^{1/2}$$

$$\text{Hence } r = \frac{I_{a.c. rms}}{I_{dc}} = \frac{\left[I_{r.m.s}^2 - I_{dc}^2 \right]^{1/2}}{I_{dc}} = \left[\frac{I_{r.m.s}^2 - I_{dc}^2}{I_{dc}^2} \right]^{1/2}$$

$$= \left[\left(\frac{I_{r.m.s}}{I_{dc}} \right)^2 - 1 \right]^{1/2} = \sqrt{\frac{I_{r.m.s}^2}{I_{dc}^2} - 1}$$

Ripple factor for half wave rectifier.

We know that $I_{rms} = \frac{I_m}{2}$

I_{dc} or $I_{avg} = \frac{I_m}{\pi}$

$$r = \sqrt{\frac{I_{rms}^2}{I_{dc}^2} - 1} \quad \text{--- (1)}$$

now put the value of I_{rms} & I_{dc} in eq (1)

then we get

$$r = \sqrt{\frac{(I_m/2)^2}{(I_m/\pi)^2} - 1}$$

$$= \sqrt{\frac{I_m^2}{4} \times \frac{\pi^2}{I_m^2} - 1}$$

$$= \sqrt{\frac{\pi^2}{4} - 1} = 1.21$$

Ripple factor for full wave rectifier

We know that $I_{rms} = \frac{I_m}{\sqrt{2}}$

$I_{dc} = \frac{2I_m}{\pi}$

$$r = \sqrt{\frac{I_{rms}^2}{I_{dc}^2} - 1} \quad \text{--- (2)}$$

put the value of I_{rms} & I_{dc} at eq (2)

$$= \sqrt{\frac{(I_m/\sqrt{2})^2}{(2I_m/\pi)^2} - 1} = \sqrt{\frac{I_m^2}{2} \times \frac{\pi^2}{4I_m^2} - 1}$$

$$= \sqrt{\frac{\pi^2}{8} - 1} = 0.48$$

3.3 Filters:

Filter circuit is a device which removes the a.c. component of rectifier out put but allows the d.c. component to reach the load

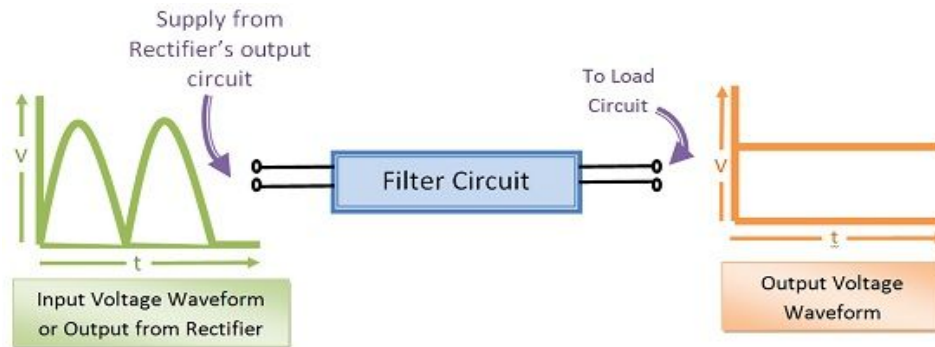

Necessity of filter circuit

The **filter** circuit is necessary for smoothing of the voltage obtained by the rectifier. The obtained DC voltage contains AC components. These AC components are called **ripples**. The filter circuit is needed to remove the ripples from DC output voltage so that the output voltage across the load will be regulated

Ripple is wasted power, and has many undesirable effects in a DC circuit: **it heats components, causes noise and distortion, and may cause digital circuits to operate improperly**. Ripple may be reduced by an electronic filter, and eliminated by a voltage regulator.

Type of filter circuit

- b. Series Inductor Filter**
- c. Shunt Capacitor Filter**
- d. Choke Filter**
- e. π Filter**

a. Series Inductor Filter

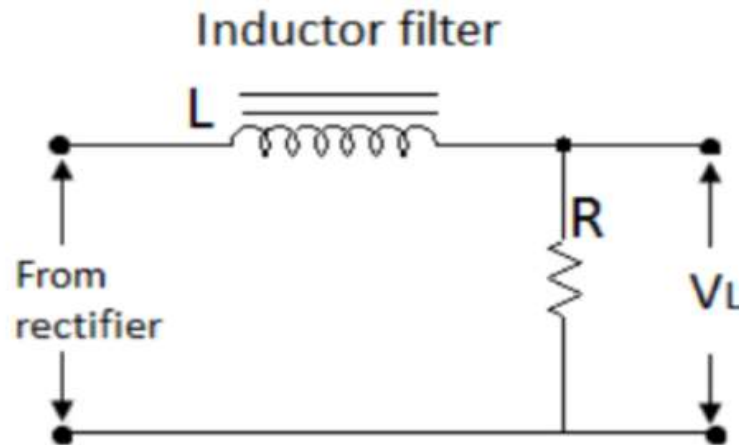

In series inductor filter the inductor is connected in series with the rectifier output and the load resistor shown in fig . Thus, it is called series inductor filter.

The property of an inductor is the inductance reactance is given by $X_L = 2\pi FL$. The inductance reactance increases with increase in the frequency of the a.c. current and frequency of dc. Current is Zero it means to block AC and provides zero resistance to DC so inductor is used in filtering circuit. When the value of DC output from the rectifier is more than the average value then the rectifier store the excess current in the form of magnetic energy.

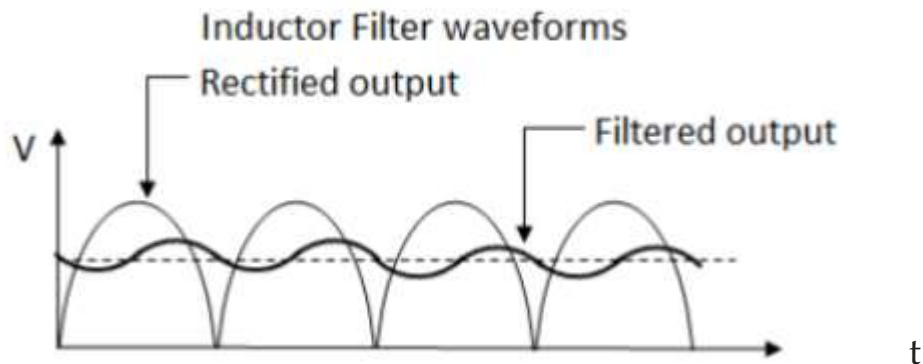

When the value of DC from the rectifier is less than the average value then the inductor release the stored magnetic energy in order to balance the effect of the low value of DC. In this way series inductor filter maintains the regulated DC supply. Moreover,

inductor blocks the AC ripples present in the output voltage of rectifier; thus, smooth DC signal can be obtained. Shown in out put waveform.

b. Shunt Capacitor Filter

The large value of capacitor is connected in parallel with respect to the output of rectifier circuit and also in parallel with the load resistor. The rectifier output is applied across the capacitor and out put voltage is taken across the load resistor R_L as shown in fig

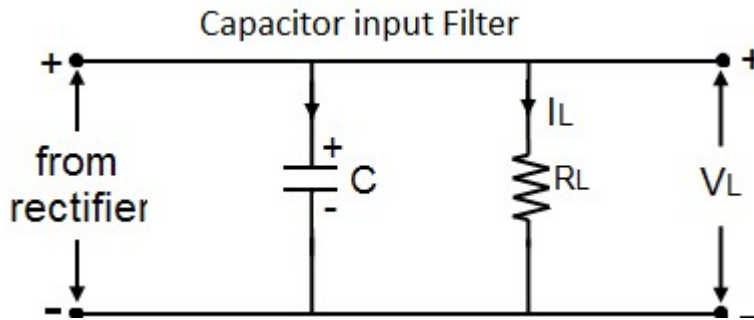

Working of capacitor in shunt capacitor Filter

When the rectifier voltage is applied, the capacitor charges to its peak voltage level. So the voltage across a capacitor becomes equal to output voltage of rectifier

When the rectifier voltage decrease , the capacitor starts discharges through load resistance R_L . So the output voltage also decreases. The charging and discharging of capacitor is shown in fig.

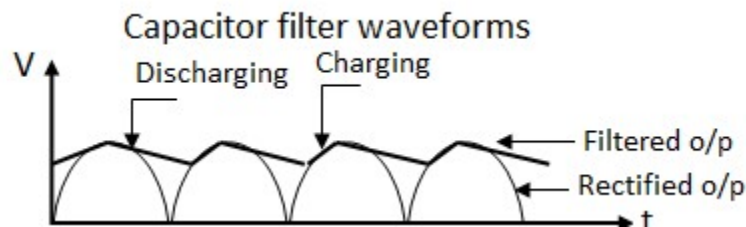

The value of load resistance R_L is large so that the capacitor discharges slowly and the voltage across the capacitor falls slightly less than the peak value of rectifier voltage

When there is the next pulse the capacitor charges to a peak value. Thus, the process repeats and the output voltage almost equal to peak value and smooth DC voltage is maintained across RL

The discharge time(T) of a capacitor (C) depends on the product ($\tau = T.C$). if load resistance RL is small, the capacitor will discharge quickly before the next half cycle and the voltage across the load will not remain steady.

The filtering action of the capacitor filter can be explained by using its reactance. The capacitive reactance of a capacitor is given by

$$X_C = \frac{1}{2\pi fC}$$

For D.C. the frequency is zero therefore the reactance is infinity i.e $X_C = \infty$ it means that the capacitor act as an open for D.C. component cannot pass through a capacitor it passes only through the load resistance RL

As A.C having the frequency a capacitor acts as a short and so A.C. component pass through the capacitor to ground. In this way, a capacitor maintains a smooth D.C. voltage across it

Advantages:

1. It is low cost and small size filter
2. It is not affected by magnetic interference.
3. It is suitable for high voltage application

Disadvantages:

1. It is not suitable for heavy load current
2. Its required large value of the capacitor

c. Choke Filter

Choke filter consists of an inductor connected in series with rectifier output circuit and a capacitor connected in parallel with the load resistor.

It is also called **L-section filter** because the inductor and capacitor are connected in the shape of inverted L. The output pulsating DC voltage from a rectifier circuit passes through the inductor or choke coil.

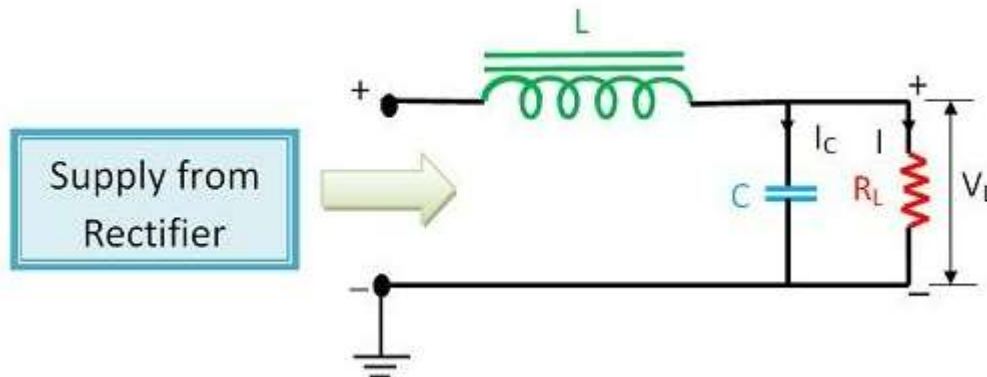

Working of Choke Filter or L-section filter

When the pulsating DC signal from the output of the rectifier circuit is feed into choke filter, the AC ripples present in the output DC voltage gets filtered by choke coil. The inductor has the property to block AC and pass DC. This is because DC resistance of an inductor is low and AC impedance of inductor coil is high. Thus, the AC ripples get blocked by inductor coil.

Although the inductor efficiently removes AC ripples, a small percentage of AC ripples is still present in the filtered signal. These ripples are then removed by the capacitor connected in parallel to the load resistor. Now, the DC output signal is free from AC components, and this regulated DC can be used in any application.

If the inductor of high inductive reactance (X_L), greater than the capacitive reactance at ripple frequency is used than filtering efficiency gets improved.

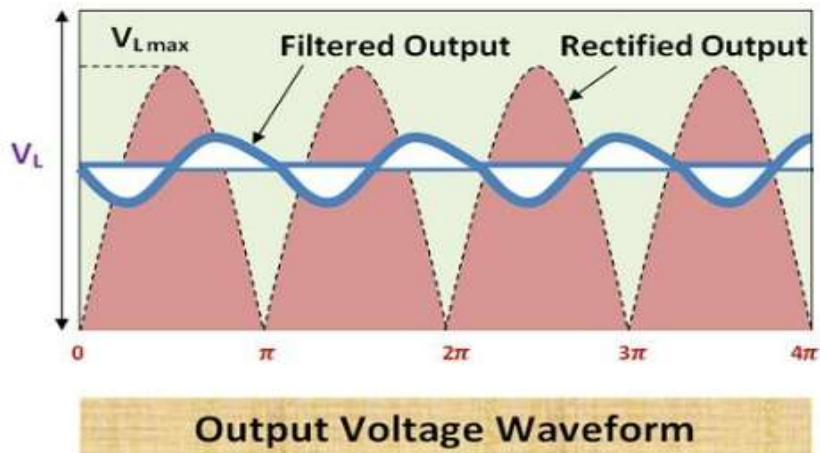

d. π Filter

The construction arrangement of all the components resembles the shape of Greek letter Pi (π). Thus it is called **Pi filter**. Besides, the capacitor is present at the input side. Thus, it is also called **capacitor input filter**.

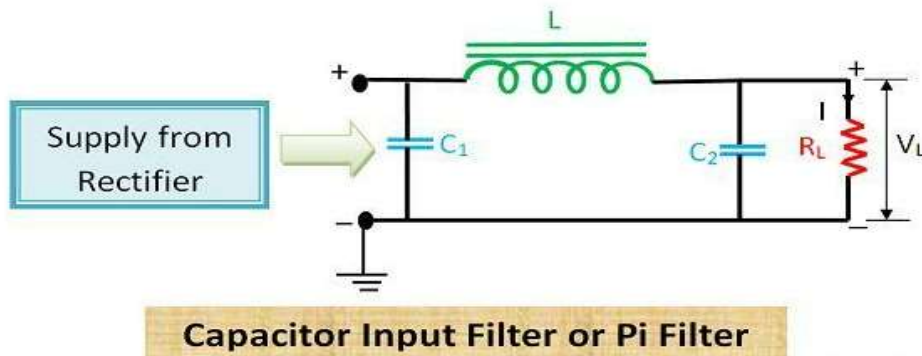

Working of Pi filter (π - filter)

The output voltage coming from rectifier also consist of AC components. Thus it is a crucial need to remove these AC ripples to improve the performance of the device. The output from the rectifier is directly applied to the input capacitor. The capacitor provides a low impedance to AC ripples present in the output

voltage and high resistance to DC voltage. Therefore, most of the AC ripples get bypassed through the capacitor in input stage only.

The residual AC components which are still present in filtered DC signal gets filtered when they pass through the inductor coil and through the capacitor connected parallel across the load. In this way, the efficiency of filtering increases multiple times.

In the case of L-section filter, one inductor and capacitor were present so if some AC ripples say 1% is left after filtering that can be removed in Pi-filter. Thus, Pi filter is considered more efficient.

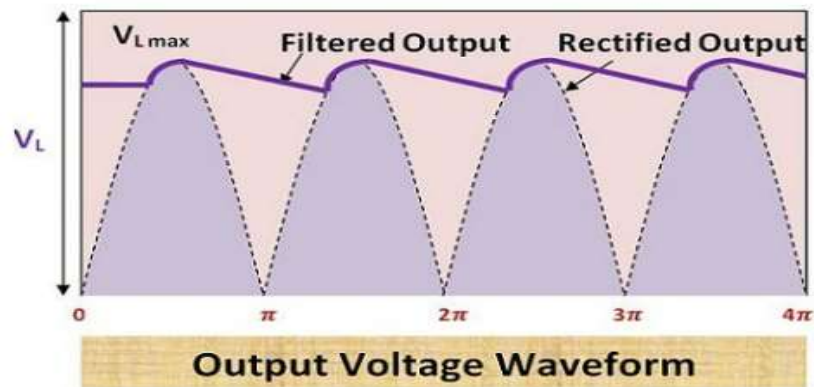

TRANSISTORS

A Bipolar Junction Transistor (BJT) is a three-terminal device which consists of two pn-junctions formed by sandwiching either p-type or n-type semiconductor material between a pair of opposite type semiconductors.

It is a current controlled device. The three terminals of the BJT are the base, the collector and the emitter. A BJT is a type of transistor that uses both electrons and holes as charge carriers so called as Bipolar Junction Transistor (BJT)

The emitter is the most heavily doped of the three regions. Also, the width of the emitter is normally smaller than the collector and greater than the base, while the base width is the smallest of the three. The emitter is heavily doped so that it can inject a large number of charge carriers (electrons or holes) into the base. The base is lightly doped and very thin, it passes most of the emitter injected charge carriers to the collector. The collector is moderately doped.

The primary function of BJT is to increase the strength of a weak signal, i.e., it acts as an amplifier. A BJT can also be used as a solid state switch in electronic circuits.

Terminals/Regions of a transistor

BJT consists of 3 regions all of which have a different doping concentration. They are–

- 1. Emitter**
- 2. Base**
- 3. Collector**

1. Emitter

The emitter is the portion on one side of the transistor which emits (supply) electrons or holes to the other two portions.

The emitter is always forward bias w.r.t base in both PNP and NPN transistors, so that it can emit a large number of **majority carriers** as it is the most heavily doped region of the BJT. Emitter supplies electrons to the emitter-base junction in NPN while it supplies holes into the same junction in PNP transistor.

2. Base

The base is the middle portion between **collector** and **emitter** & it forms two PN junctions between them.

The base is the most lightly doped portion of the BJT. Being the middle portion of the BJT allows it to control the flow of charge carriers between emitter and collector.

The base-emitter junction is forward bias, allowing low resistance for emitter circuit.

The base-collector junction shows high resistance because this junction is reversed bias.

The base-collector junction shows high resistance because this junction is reversed bias.

3. Collector

The portion on the opposite side of the Emitter that collects the emitted charge carriers (i.e. electrons or holes) is known as **collector**.

Collector-base junction should be always reversed biased in both PNP and NPN transistors.

The reason for reverse biasing is to remove charge carriers (electrons or holes) from the collector-base junction.

The collector of NPN transistor collects electrons emitted by emitter. While in PNP transistor, it collects holes emitted by emitter.

Types of BJT

There are two types of BJTs –

- NPN Transistor
- PNP Transistor

NPN Transistor

An npn-transistor is composed of two n-type semiconductor materials which are separated by a thin layer of p-type semiconductor.

The two terminals viz. Emitter and Collector are taken out from the two n-type semiconductor and the Base terminal is from the p-type semiconductor.

For npn-transistor, the conventional current flows out of the emitter as indicated by the outgoing arrow.

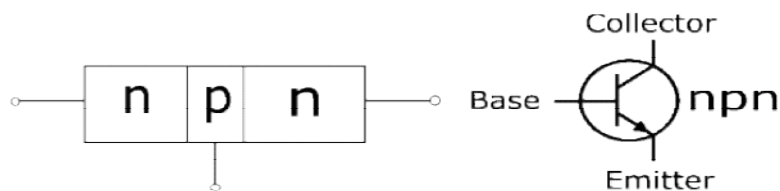

PNP Transistor

A pnp-transistor is composed of two p-type semiconductors which are separated by a thin layer of n-type material.

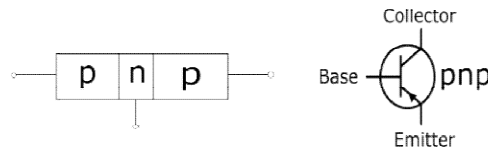

The two terminals viz. Emitter and Collector are taken out from the two p-type semiconductor layers and the Base terminal is from the n-type semiconductor.

For the pnp-transistor, the conventional current flows into the emitter as indicated by the inward arrow.

4.1 Principle of Bipolar junction transistor

Base-Emitter junction (BE) is forward bias while **collector-emitter junction (CE)** is reverse bias. At BE junction, the potential barrier decreases with forward bias. So, electron start flowing from emitter terminal to base terminal.

As the base is lightly doped terminal, so very little number of electrons from emitter terminal combine with holes in base terminal.

Due to combination of electrons and holes, current from base terminal will start flowing known as **Base current (i_b)**.

Base current is only 2% of the emitter current I_e while the remaining electrons will flow from the reverse bias collector junction known as **Collector current (i_c)**.

The total emitter current will be the combination of base current & collector current given by;

$$i_e = i_b + i_c$$

Where i_e is approximately equal to i_c because I_b is almost 2% of the I_c .

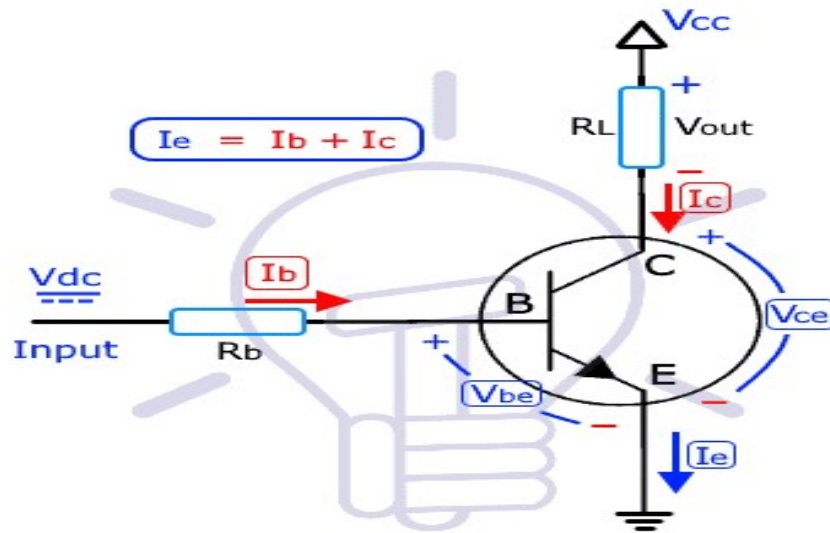

Bipolar Junction Transistor (BJT)

Working of NPN Transistor

With the forward-biased emitter-base junction and reverse-biased collector-base junction, it can be seen that the forward bias causes the flow of electrons from the n-type emitter into the p-type base. This constitutes the emitter current (I_E). As these electrons flow through the p-type base, they tend to combine with the holes.

Since the base is lightly doped and very thin, hence, only a small number electrons (less than 5%) combine with the holes to constitute the base current (I_B). The remaining (more than 95%) electrons cross over the base region and reach to the collector region to constitute the collector current (I_C). In this manner, the entire emitter current flows in the collector circuit.

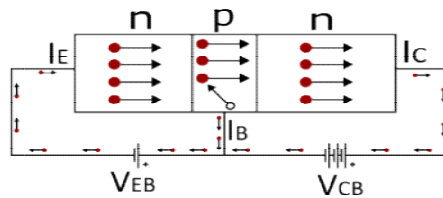

The emitter current is the sum of base and collector currents.

$$I_E = I_B + I_C$$

Working of PNP Transistor

For the pnp-transistor, the forward bias of emitter-base junction causes the flow of holes in the p-type emitter region towards the n-type base and constitutes the emitter current (I_{E1}). As these holes cross into the n-type base region, they tend to combine with the electrons. Since the base is lightly doped and very thin, hence only a small number of holes (less than 5%) combine with the electrons. The remaining (more than 95%) cross the base and reach into the collector region to constitute the collector current (I_{C1}).

In this manner, the entire emitter current flows into the collector circuit. It may be noted that the current conduction inside the pnp-transistor is due to the movement of holes. However, in the external connecting wires, the current is still due to the flow of electrons.

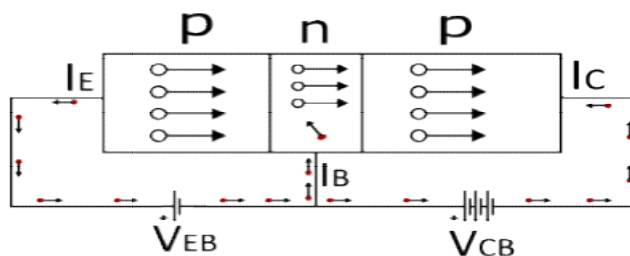

Again, the emitter current is the sum of collector current and base current.

$$I_E = I_B + I_C$$

4.2 Different modes of operation of transistor

transistors are non-linear devices. They have four distinct modes of operation, which describe the current flowing through them.

These biasing methods make the transistor circuit to work in four kinds of regions (mode) such as

1. **Active region**
2. **Saturation region**
3. **Cutoff region**
4. **Inverse active region**

Emitter Junction	Collector Junction	Region of Operation
Forward biased	Forward biased	Saturation region
Forward biased	Reverse biased	Active region
Reverse biased	Forward biased	Inverse active region
Reverse biased	Reverse biased	Cut off region

1. Active region

This is the region in which transistors have many applications. This is also called as **linear region**. A transistor while in this region, acts better as an **Amplifier**.

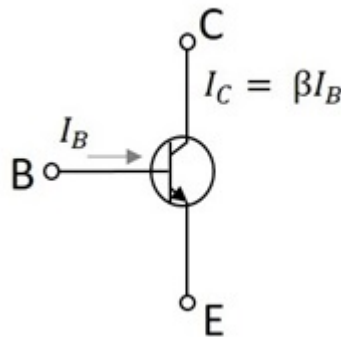

This region lies between saturation and cutoff. The transistor operates in active region when the emitter junction is forward biased and collector junction is reverse biased.

In the active state, collector current is β times the base current, i.e.

$$I_C = \beta I_B$$

Where I_C = collector current, β = current amplification factor, and I_B = base current.

In this region, the transistor is used for amplification

2. Saturation region

This is the region in which transistor tends to behave as a closed switch. The transistor has the effect of its collector and emitter being shorted. The collector and emitter currents are maximum in this mode of operation.

The following figure shows a transistor working in saturation region.

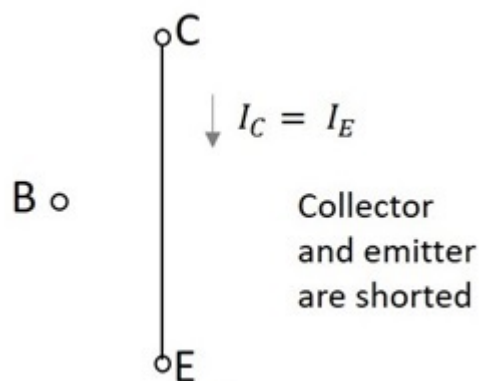

The transistor operates in saturation region when both the emitter and collector junctions are forward biased.

In saturation mode,

$$\beta < \frac{I_C}{I_B}$$

As in the saturation region the transistor tends to behave as a closed switch,

$$I_C = I_E$$

Where I_C = collector current and I_E = emitter current.

3. Cutoff region

This is the region in which transistor tends to behave as an open switch. The transistor has the effect of its collector and base being opened. The collector, emitter and base currents are all zero in this mode of operation.

The figure below shows a transistor working in cutoff region.

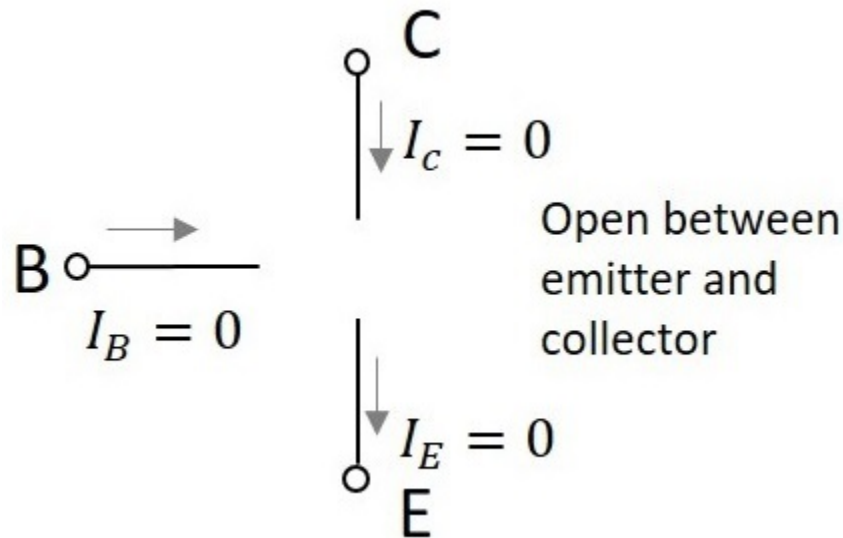

The transistor operates in cutoff region when both the emitter and collector junctions are reverse biased.

As in cutoff region, the collector current, emitter current and base currents are nil, we can write as

$$I_C = I_E = I_B = 0$$

Where I_C = collector current, I_E = emitter current, and I_B = base current.

4.4 Transistor as an amplifier:

A transistor acts as an amplifier by raising the strength of a weak signal. The DC bias voltage applied to the emitter base junction makes it remain in forward biased condition. This forward bias is maintained regardless of the polarity of the signal. The below figure shows how a transistor looks like when connected as an amplifier.

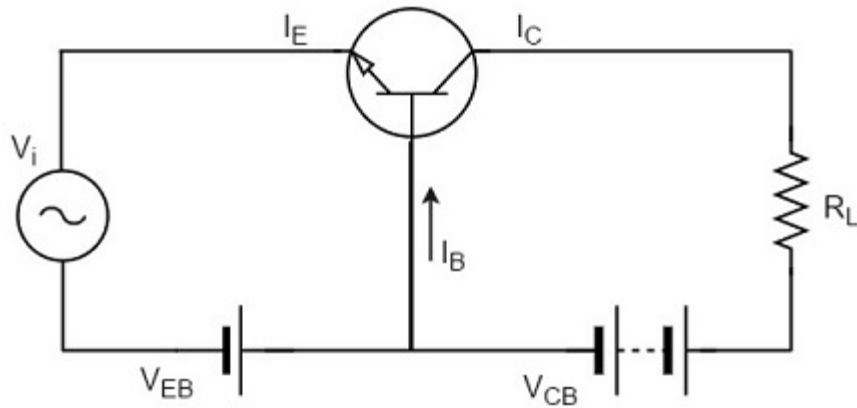

The low resistance in input circuit as Emitter base is forward bias , lets any small change in input signal to result in an appreciable change in the output. The emitter current caused by the input signal contributes the collector current, which when flows through the load resistor R_L , results in a large voltage drop across it as reverse bias i.e high resistance at out put side . Thus a small input voltage results in a large output voltage, which shows that the transistor works as an amplifier.

Example

Let there be a change of 0.1v in the input voltage being applied, which further produces a change of 1mA in the emitter current. This emitter current will obviously produce a change in collector current, which would also be 1mA.

A load resistance of 5kΩ placed in the collector would produce a voltage of

$$5 \text{ k}\Omega \times 1 \text{ mA} = 5\text{V}$$

Hence it is observed that a change of 0.1v in the input gives a change of 5v in the output, which means the voltage level of the signal is amplified.

4.5 Transistor circuit configuration & its characteristics

Generally the transistor has three terminals – emitter (E), base (B) and collector. But in the circuit connections we need four terminals, two terminals for input and another two terminals for output.

To overcome these problems we use one terminal as common for both input and output actions.

Using this property we construct the circuits and these structures are called transistor configurations. Generally there are three different configurations of transistors are:

- a) **Common Base (CB) Configuration.**
- b) **Common Emitter (CE) Configuration.**
- c) **Common Collector (CC) Configuration.**

A. Common Base (CB) Configuration

The name itself implies that the Base terminal is taken as common terminal for both input and output of the transistor. The common base connection for both NPN and PNP transistors is as shown in the following figure.

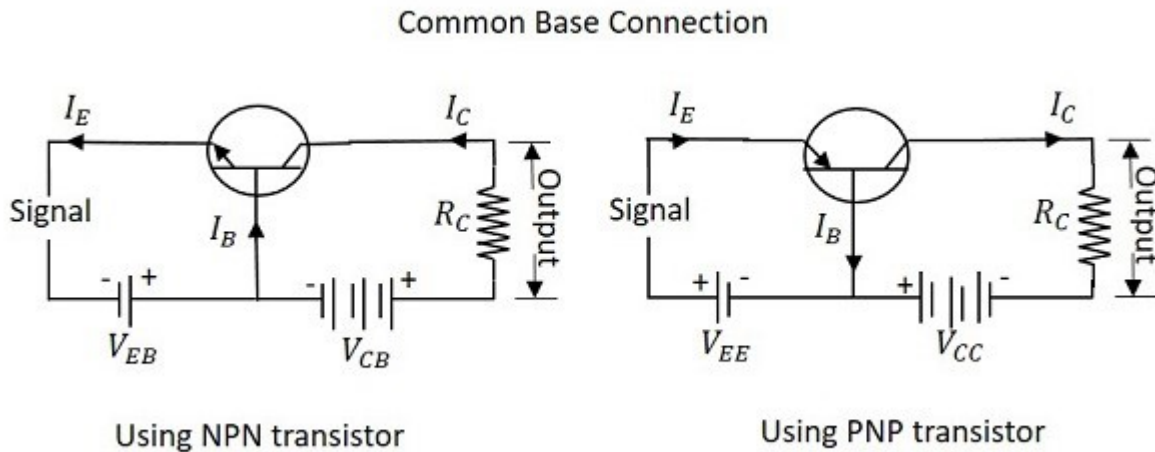

let us consider NPN transistor in CB configuration. When the emitter voltage is applied, as it is forward biased, the electrons from the negative terminal repel the emitter electrons and current flows through the emitter and base to the collector to contribute collector current. The collector voltage VCB is kept constant throughout this.

In the CB configuration, the input current is the emitter current I_E and the output current is the collector current I_C .

Current Amplification Factor (α):

The ratio of change in collector current (ΔI_C) to the change in emitter current (ΔI_E) when collector voltage V_{CB} is kept constant, is called as **Current amplification factor**. It is denoted by α .

$$\alpha = \frac{\Delta I_C}{\Delta I_E} \text{ at constant } V_{CB}$$

Input Characteristics for CB Configuration of Transistor:

The curve between emitter current I_E and emitter base voltage V_{EB} at constant collector base voltage V_{CB} shows in the fig the input characteristics of a CB configuration circuit which describes the variation of emitter current, I_E with Base-Emitter voltage, V_{BE} keeping Collector-Base voltage, V_{CB} constant.

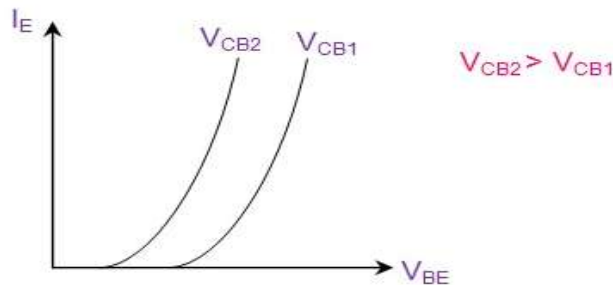

This leads to the expression for the input resistance as

$$R_{in} = \left. \frac{\Delta V_{BE}}{\Delta I_E} \right|_{V_{CB} = \text{constant}}$$

Output Characteristics for CB Configuration of Transistor:

The curve between collector current I_C and collector base voltage V_{CB} at constant emitter current I_E shows in the fig. The output characteristics of CB configuration

Figure show the variation of collector current, I_C with V_{CB} when the emitter current, I_E is held constant. From the graph shown,

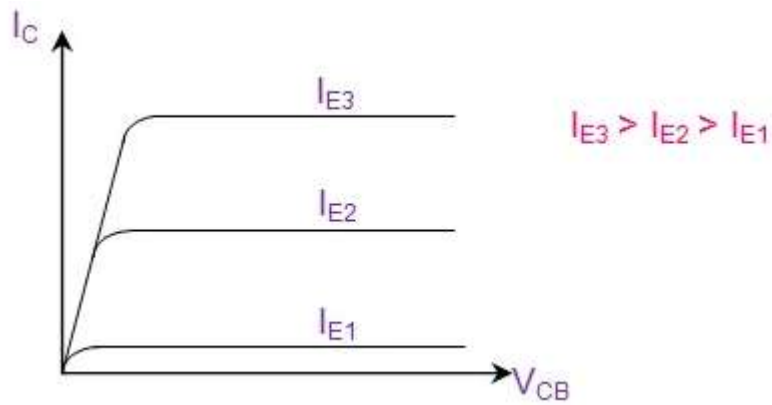

The output resistance can be obtained as:

$$R_{out} = \left. \frac{\Delta V_{CB}}{\Delta I_C} \right|_{I_E = \text{constant}}$$

B. Common Emitter (CE) Configuration.

The name itself implies that the **Emitter** terminal is taken as common terminal for both input and output of the transistor. The common emitter connection for both NPN and PNP transistors is as shown in figure.

Common Emitter Connection

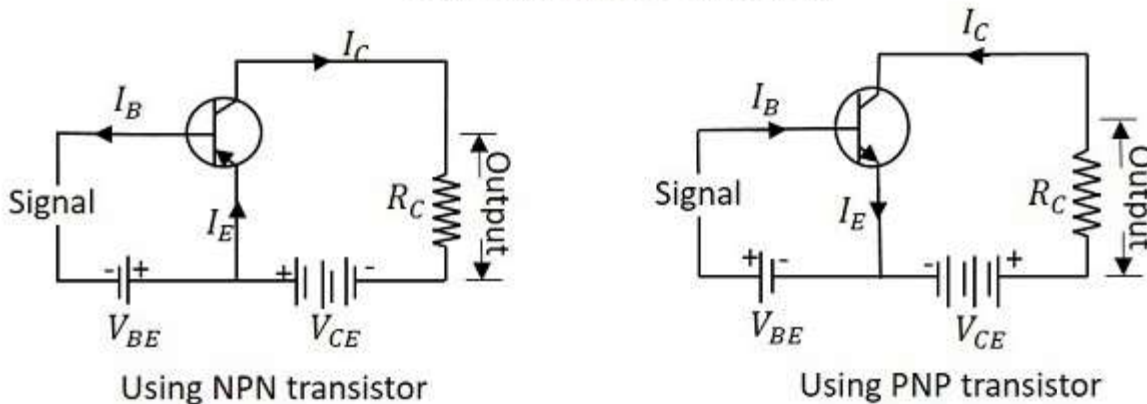

The emitter junction is forward biased and the collector junction is reverse biased. The input current is the base current I_B and the output current is the collector current I_C here.

Base Current Amplification factor β

The ratio of change in collector current ΔI_C to the change in base current ΔI_B is known as Base Current Amplification Factor. It is denoted by β

$$\beta = \frac{\Delta I_C}{\Delta I_B} \text{ at constant } V_{CE}$$

Input Characteristics for CE Configuration of Transistor:

The curve between base current I_B and base emitter voltage V_{BE} at constant collector emitter voltage V_{CE} shows in the Figure shows the input characteristics for the CE configuration of transistor which illustrates the variation in I_B in accordance with V_{BE} when V_{CE} is kept constant.

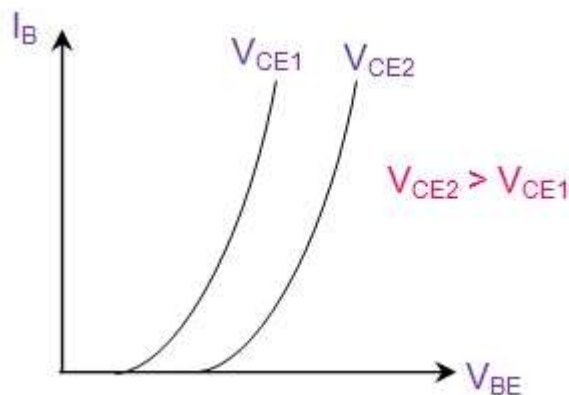

The input resistance of the transistor can be obtained as

$$R_{in} = \frac{\Delta V_{BE}}{\Delta I_B} \Big|_{V_{CE} = \text{constant}}$$

Output Characteristics for CE Configuration of Transistor:

The curve between collector current I_C and collector emitter voltage V_{CE} at constant base current I_B shows in the fig.. The output characteristics of CE configuration (Figure 11) are also referred to as collector characteristics. This plot shows the variation in I_C with the changes in V_{CE} when I_B is held constant.

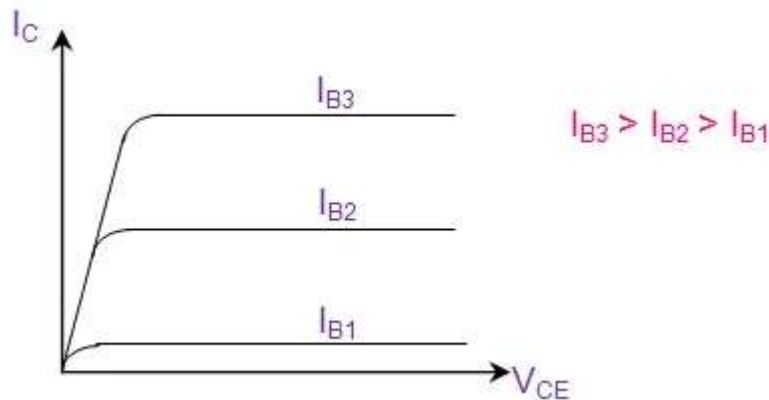

From the graph shown, the output resistance can be obtained as:

$$R_{out} = \frac{\Delta V_{CE}}{\Delta I_C} \Big|_{I_B = \text{constant}}$$

C. Common Collector (CC) Configuration.

The name itself implies that the **Collector** terminal is taken as common terminal for both input and output of the transistor. The common collector connection for both NPN and PNP transistors is as shown in the following figure.

Common Collector Connection

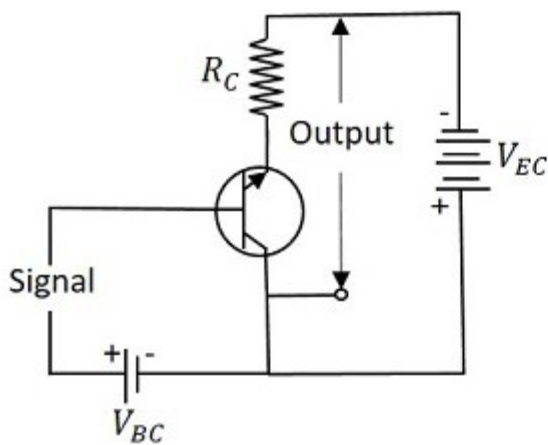

Using NPN transistor

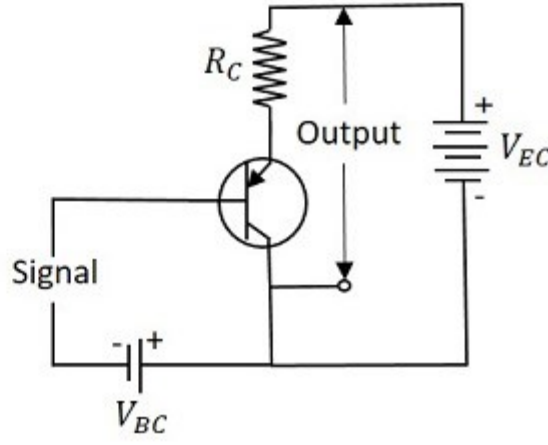

Using PNP transistor

Just as in CB and CE configurations, the emitter junction is forward biased and the collector junction is reverse biased. The input current is the base current I_B and the output current is the emitter current I_E here.

Current Amplification Factor γ

The ratio of change in emitter current ΔI_E to the change in base current ΔI_B is known as **Current Amplification factor** in common collector CC configuration. It is denoted by γ

$$\gamma = \frac{\Delta I_E}{\Delta I_B}$$

- The current gain in CC configuration is same as in CE configuration.
- The voltage gain in CC configuration is always less than 1.

Input Characteristics for CC Configuration of Transistor

Figure shows the input characteristics for CC configuration which describes the variation in I_B in accordance with V_{CB} , for a constant value of Collector-Emitter voltage, V_{CE} .

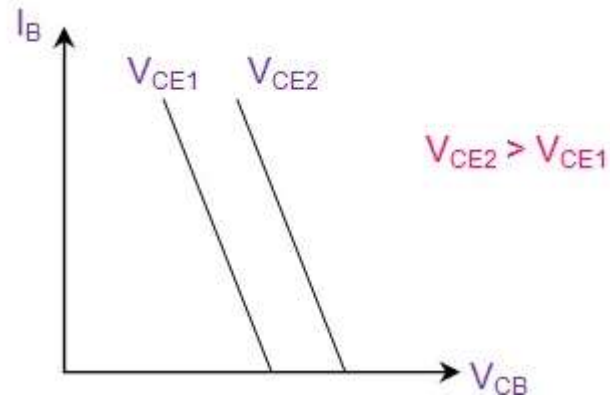

Output Characteristics for CC Configuration of Transistor

Figure 7 below shows the output characteristics for the CC configuration which exhibit the variations in I_E against the changes in V_{CE} for constant values of I_B .

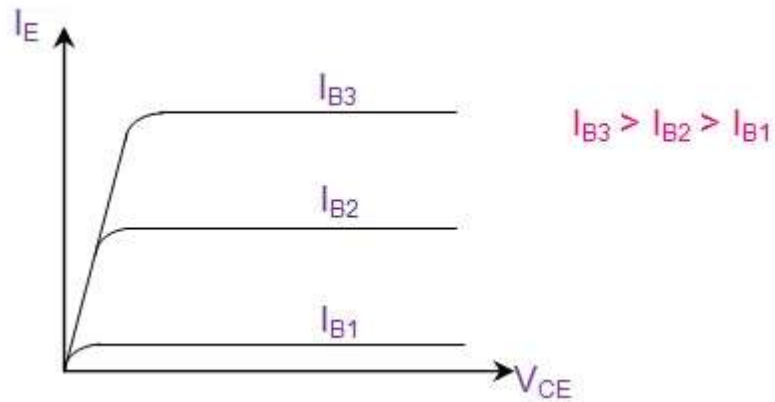

Relation between β and α

We know that $\beta = \frac{\Delta I_C}{\Delta I_B} \dots\dots\dots 1$.

$$\alpha = \frac{\Delta I_C}{\Delta I_E} \dots\dots\dots 2.$$

$$I_E = I_B + I_C$$

$$\Delta I_E = \Delta I_B + \Delta I_C$$

$$\Delta I_B = \Delta I_E - \Delta I_C \dots\dots\dots 3.$$

Put the value of ΔI_B in equation 1 we get

$$\beta = \frac{\Delta I_C}{\Delta I_E - \Delta I_C}$$

divide the denominator and numerator by ΔI_E

$$\beta = \frac{\frac{\Delta I_C}{\Delta I_E}}{\frac{\Delta I_E}{\Delta I_E} - \frac{\Delta I_C}{\Delta I_E}}$$

$$\alpha = \frac{\Delta I_C}{\Delta I_E}$$

$$\beta = \frac{\alpha}{1 - \alpha}$$

Comparison of Transistor Configuration

The following table shows the comparison of transistor configuration.

Characteristics	Common Emitter	Common Base	Common Collector
Current Gain	High	No	Considerable
Applications	Audio frequency	High frequency	Impedance matching
Input Resistance	Low	Low	Very high
Output Resistance	High	Very high	Low
Voltage Gain	Approx. 500	Approx. 150	Less than 1

5. TRANSISTOR CIRCUITS

5.1 Transistor biasing:

The proper flow of zero signal collector current and the maintenance of proper collector emitter voltage during the passage of signal is known as **Transistor Biasing**. The circuit which provides transistor biasing is called as **Biasing Circuit**.

Need for DC biasing

If a signal of very small voltage is given to the input of BJT, it cannot be amplified. Because, for a BJT, to amplify a signal, two conditions have to be met.

- The input voltage should exceed **cut-in voltage** for the transistor to be **ON**.
- The BJT should be in the **active region**, to be operated as an **amplifier**.

Factors affecting the operating point

The main factor that affects the operating point is the temperature. The operating point shifts due to change in temperature.

As temperature increases, the values of I_{CE} , β , V_{BE} gets affected.

- I_{CBO} gets doubled (for every 10° rise)
- V_{BE} decreases by 2.5mv (for every 1° rise)

So the main problem which affects the operating point is temperature. Hence operating point should be made independent of the temperature so as to achieve stability. To achieve this, biasing circuits are introduced.

5.2 Stabilization

The process of making the operating point independent of temperature changes or variations in transistor parameters is known as **Stabilization**.

Once the stabilization is achieved, the values of I_C and V_{CE} become independent of temperature variations or replacement of transistor. A good biasing circuit helps in the stabilization of operating point.

Need for Stabilization

Stabilization of the operating point has to be achieved due to the following reasons.

- **Temperature dependence of I_c**
- **Individual variations**
- **Thermal runaway**

Let us understand these concepts in detail.

Temperature Dependence of I_C :

As the expression for collector current I_c is

$$\begin{aligned} I_C &= \beta I_B + I_{CEO} \\ &= \beta I_B + (\beta + 1) I_{CBO} \end{aligned}$$

The collector leakage current I_{CBO} is greatly influenced by temperature variations. To come out of this, the biasing conditions are set so that zero signal collector current $I_c = 1$ mA. Therefore, the operating point needs to be stabilized i.e. it is necessary to keep I_c constant.

Individual Variations:

As the value of β and the value of V_{BE} are not same for every transistor, whenever a transistor is replaced, the operating point tends to change. Hence it is necessary to stabilize the operating point.

Thermal Runaway:

As the expression for collector current I_c is

$$\begin{aligned} I_C &= \beta I_B + I_{CEO} \\ &= \beta I_B + (\beta + 1) I_{CBO} \end{aligned}$$

The flow of collector current and also the collector leakage current causes heat dissipation. If the operating point is not stabilized, there occurs a cumulative effect which increases this heat dissipation.

The self-destruction of such an un-stabilized transistor is known as **Thermal runaway**.

In order to avoid **thermal runaway** and the destruction of transistor, it is necessary to stabilize the operating point, i.e., to keep I_c constant.

5.3 Stability Factor:

It is understood that I_c should be kept constant in spite of variations of I_{CBO} or I_{CO} . The extent to which a biasing circuit is successful in maintaining this is measured by **Stability factor**. It denoted by **S**.

The rate of change of collector current I_c with respect to the collector leakage current I_{CO} at constant β and I_B is called Stability factor.

$$S = \frac{dI_c}{dI_{CO}} \text{ at constant } I_B \text{ and } \beta$$

The stability factor should be as low as possible so that the collector current doesn't get affected. $S=1$ is the ideal value.

The general expression of stability factor for a CE configuration can be obtained as under.

$$I_c = \beta I_B + (\beta + 1) I_{CO}$$

Differentiating above expression with respect to I_c , we get

$$1 = \beta \frac{dI_B}{dI_C} + (\beta + 1) \frac{dI_{CO}}{dI_C}$$

Or

$$1 = \beta \frac{dI_B}{dI_C} + \frac{(\beta + 1)}{S}$$

$$\text{Since } \frac{dI_{CO}}{dI_C} = \frac{1}{S}$$

Or

$$S = \frac{\beta + 1}{1 - \beta \left(\frac{dI_B}{dI_C} \right)}$$

Hence the stability factor S depends on β , I_B and I_C .

5.4 Different method of Transistors Biasing:

The commonly used methods of transistor biasing are:

- **Base Resistor method**
- **Collector to Base bias**
- **Voltage-divider bias**

a. **Base Resistor method:**

In this method, a resistor R_B of high resistance is connected in base, as the name implies. The required zero signal base current is provided by V_{CC} which flows through R_B . The base emitter junction is forward biased, as base is positive with respect to emitter.

The required value of zero signal base current and hence the collector current (as $I_C = \beta I_B$) can be made to flow by selecting the proper value of base resistor R_B . Hence the

value of R_B is to be known. The figure below shows how a base resistor method of biasing circuit looks like.

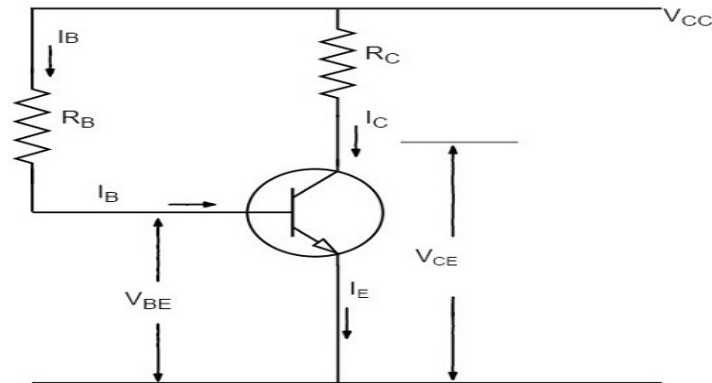

Advantages:

- The circuit is simple.
- Only one resistor R_E is required.
- Biasing conditions are set easily.
- No loading effect as no. resistor is present at base-emitter junction.

Disadvantages:

- The stabilization is poor as heat development can't be stopped.
- The stability factor is very high. So, there are strong chances of thermal run away. Hence, this method is rarely employed.

b. Voltage Divider Bias Method

The **voltage divider bias method** is the most widely used method. Here, two resistors R_1 and R_2 are employed, which are connected to V_{CC} and provide biasing. The resistor R_E employed in the emitter provides stabilization.

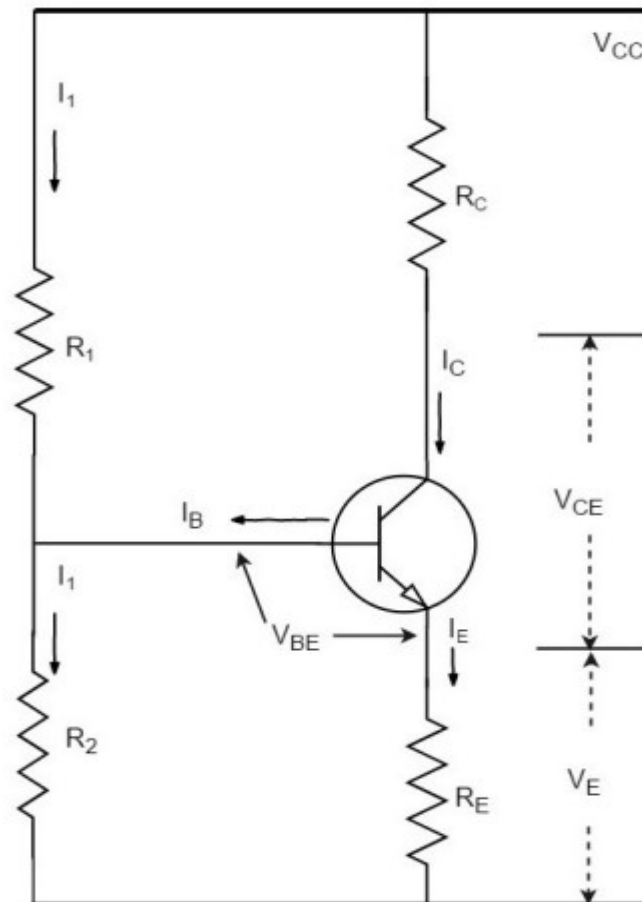

The name voltage divider comes from the voltage divider formed by R_1 and R_2 . The voltage drop across R_2 forward biases the base-emitter junction. This causes the base current and hence collector current flow in the zero signal conditions. The figure below shows the circuit of voltage divider bias method.

6. TRANSISTOR AMPLIFIERS & OSCILLATORS

6.1 Practical circuit of transistor amplifier:

The circuit of a practical transistor amplifier is as shown below, which represents a voltage divider biasing circuit.

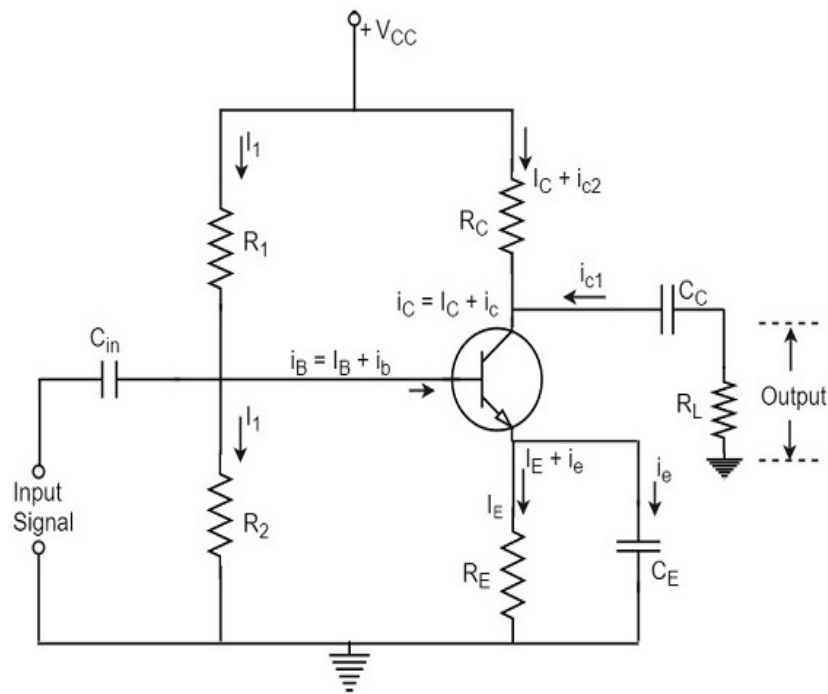

Biasing Circuit

The resistors R_1 , R_2 and R_E form the biasing and stabilization circuit, which helps in establishing a proper operating point.

Input Capacitor C_{in}

This capacitor couples the input signal to the base of the transistor. The input capacitor C_{in} allows AC signal, but isolates the signal source from R_2 . If this capacitor is not present, the input signal gets directly applied, which changes the bias at R_2 .

Coupling Capacitor C_C

This capacitor is present at the end of one stage and connects it to the other stage. As it couples two stages it is called as **coupling capacitor**. This capacitor blocks DC of one

stage to enter the other but allows AC to pass. Hence it is also called as **blocking capacitor**.

Due to the presence of coupling capacitor C_c , the output across the resistor R_L is free from the collector's DC voltage. If this is not present, the bias conditions of the next stage will be drastically changed due to the shunting effect of R_c , as it would come in parallel to R_2 of the next stage.

Emitter by-pass capacitor C_E

This capacitor is employed in parallel to the emitter resistor R_E . The amplified AC signal is by passed through this. If this is not present, that signal will pass through R_E which produces a voltage drop across R_E that will feedback the input signal reducing the output voltage.

The Load resistor R_L

The resistance R_L connected at the output is known as **Load resistor**. When a number of stages are used, then R_L represents the input resistance of the next stage.

Various Circuit currents

Let us go through various circuit currents in the complete amplifier circuit. These are already mentioned in the above figure.

Base Current

When no signal is applied in the base circuit, DC base current I_B flows due to biasing circuit. When AC signal is applied, AC base current i_b also flows. Therefore, with the application of signal, total base current i_B is given by

$$i_B = I_B + i_b$$

Collector Current

When no signal is applied, a DC collector current I_c flows due to biasing circuit. When AC signal is applied, AC collector current i_c also flows. Therefore, the total collector current i_c is given by

$$i_c = I_c + i_c$$

Where

$$I_C = \beta I_B = \text{zero signal collector current}$$
$$i_c = \beta i_b = \text{collector current due to signal}$$

Emitter Current

When no signal is applied, a DC emitter current I_E flows. With the application of signal, total emitter current i_E is given by

$$i_E = I_E + i_e$$

It should be remembered that

$$I_E = I_B + I_C$$

$$i_e = i_b + i_c$$

As base current is usually small, it is to be noted that

$$I_E \cong I_C \text{ and } i_e \cong i_c$$

6.2 DC load line and DC equivalent circuit:

DC load line:

The D.C load line is a line on the output characteristics of a transistor which gives the value of I_C and V_{CE} corresponding to zero signal conditions.

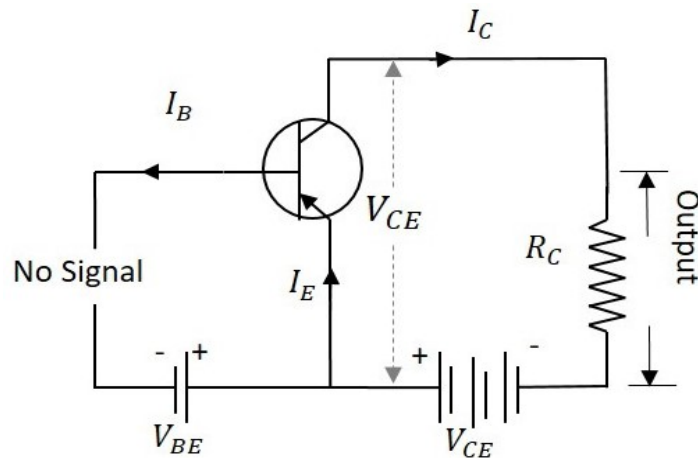

The value of collector emitter voltage at any given time will be

$$V_{CE} = V_{CC} - I_C R_C$$

As V_{CC} and R_C are fixed values, the above one is a first degree equation and hence will be a straight line on the output characteristics. This line is called as **D.C. Load line**. The figure below shows the DC load line.

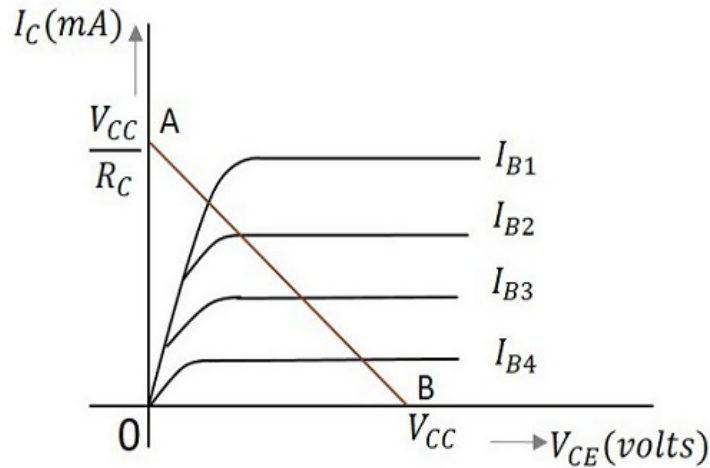

To obtain the load line, the two end points of the straight line are to be determined. Let those two points be A and B.

To obtain A

When collector emitter voltage $V_{CE} = 0$, the collector current is maximum and is equal to V_{CC}/R_C . This gives the maximum value of V_{CE} . This is shown as

$$V_{CE} = V_{CC} - I_C R_C$$

$$0 = V_{CC} - I_C R_C$$

$$I_C = V_{CC}/R_C$$

This gives the point A ($OA = V_{CC}/R_C$) on collector current axis, shown in the above figure.

To obtain B

When the collector current $I_C = 0$, then collector emitter voltage is maximum and will be equal to the V_{CC} . This gives the maximum value of I_C . This is shown as

$$V_{CE} = V_{CC} - I_C R_C$$

$$= V_{CC}$$

$$(AS I_C = 0)$$

This gives the point B, which means (OB = V_{CC}) on the collector emitter voltage axis shown in the above figure.

Hence we got both the saturation and cutoff point determined and learnt that the load line is a straight line. So, a DC load line can be drawn.

DC equivalent circuit:

In D.C. equivalent circuit of a transistor amplifier, only d.c conditions are to be considered i.e. no signal is applied. As dc current can not flow through a capacitor therefore all the capacitors look like open circuits in the d.c. equivalent circuit.

Following two steps are applied to the transistor ckt:

- I. Reduce all a.c. source to zero
- II. Open all the capacitor

Applying above two steps we get from above circuit

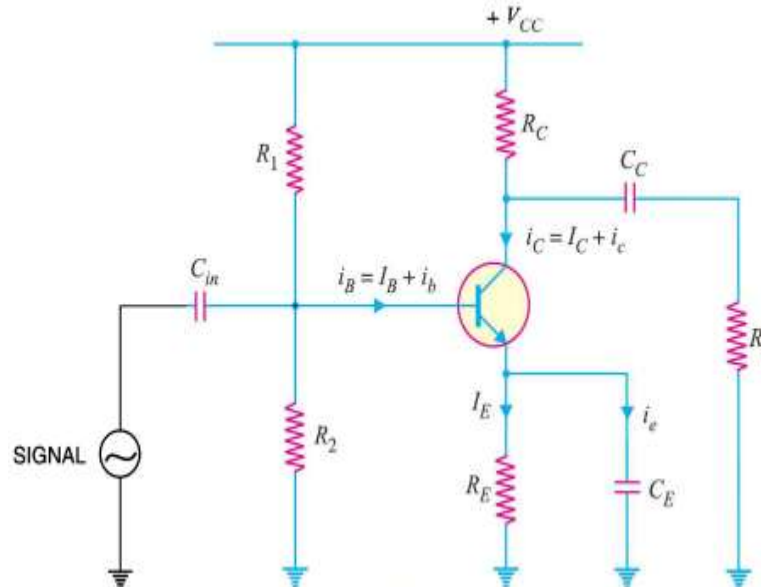
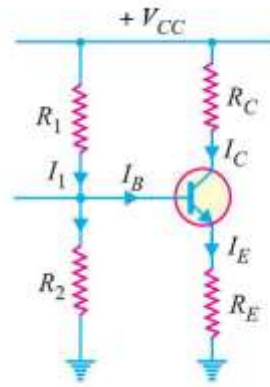

Fig-1



Fi-2 DC equivalent ckt of fig-1

AC equivalent circuit:

In the a.c. equivalent circuit of transistor amplifier, only AC conditions are to be considered.

Following two steps are applied to the transistor circuit:

- a. Reduce all d.c. sources to zero (i.e. $I_{CC}=0$)
- b. Short all the capacitors

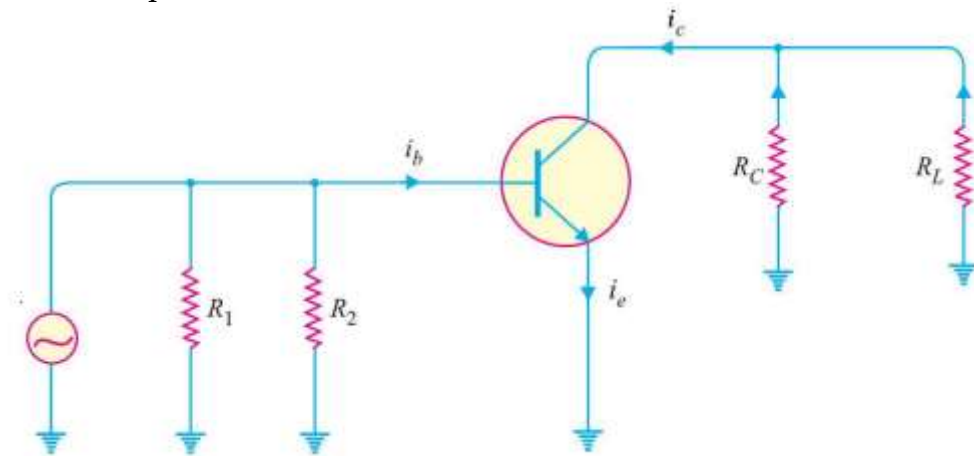

Fig-3 AC equivalent ckt of Fig =1

6.4 Calculation of gain:

1. Graphical Method

The graphical method is used to calculate the current gain and voltage gain of the amplifier.

The out put characteristics are shown in fig.

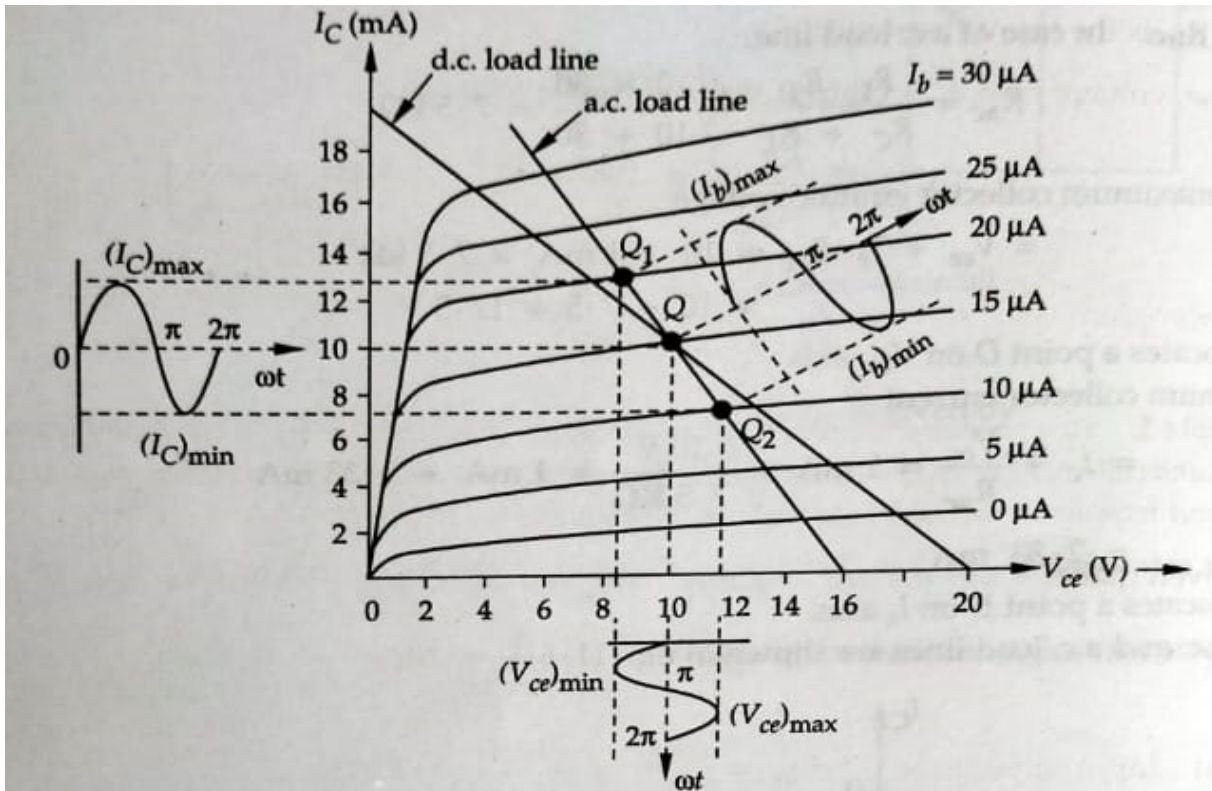

First we draw the d.c. and ac load lines. The slope of dc load line is $-1/R_{dc}$ while the slope a.c. load line $-1/R_{ac}$. Here, $R_{dc}=R_c+R_e$ and $R_{ac}=R_L || R_C$

From the fig that collector current varies between $(I_c)_{max}$ and $(I_c)_{min}$. While the collector-emitter voltage varies between $(V_{ce})_{max}$ and $(V_{ce})_{min}$. Let a.c. voltage varies between $(V_i)_{max}$ and $(V_i)_{min}$ the current gain and voltage gain are given

$$\text{Current gain} = \frac{(I_c)_{max} - (I_c)_{min}}{(I_b)_{max} - (I_b)_{min}}$$

$$\text{Voltage gain} = \frac{(V_{ce})_{max} - (V_{ce})_{min}}{(V_i)_{max} - (V_i)_{min}}$$

2. Using Circuit Analysis

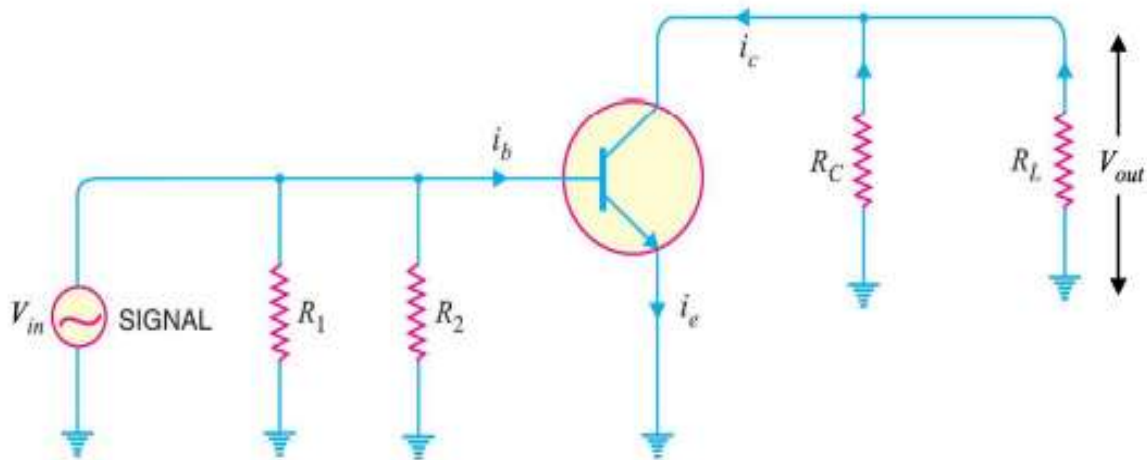

Fig. 10.19

It is clear that as far as a.c. signal is concerned, load R_C appears in parallel with R_L . Therefore, effective load for a.c. is given by :

$$\text{a.c. load, } R_{AC} = R_C \parallel R_L = \frac{R_C \times R_L}{R_C + R_L}$$

$$\text{Output voltage, } V'_{out} = i_c R_{AC}$$

$$\text{Input voltage, } V'_{in} = i_b R_{in}$$

$$\therefore \text{Voltage gain, } A_v = V'_{out} / V'_{in}$$

$$= \frac{i_c R_{AC}}{i_b R_{in}} = \beta \times \frac{R_{AC}}{R_{in}} \quad \left(\because \frac{i_c}{i_b} = \beta \right)$$

Incidentally, power gain is given by;

$$A_p = \frac{i_c^2 R_{AC}}{i_b^2 R_{in}} = \beta^2 \times \frac{R_{AC}}{R_{in}}$$

6.5 Phase reversal

The phase difference of 180° between the signal voltage and output voltage in common emitter amplifier is known as Phase reversal.

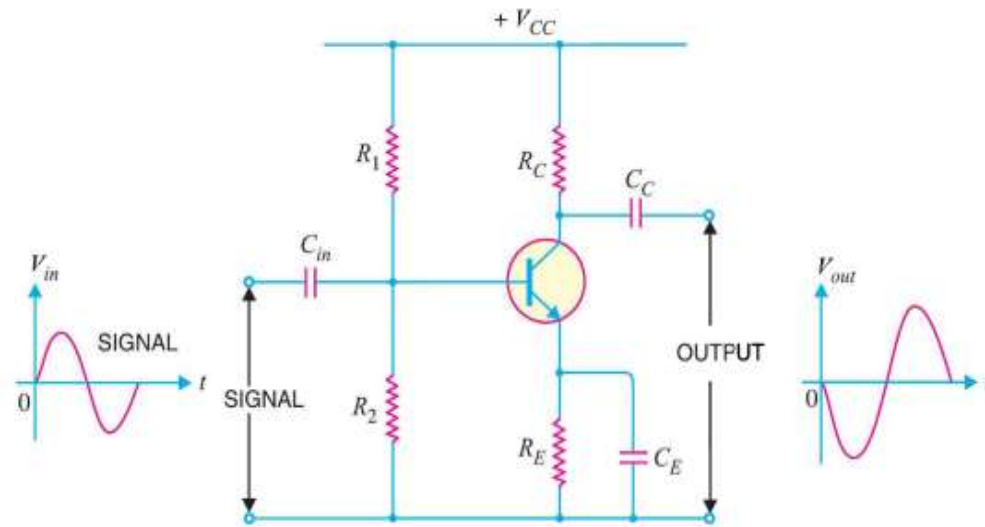

6.10 Multi stage transistor amplifier

A transistor ckt contains more than One stage of amplification is known as *multistage transistor amplifier*

In a multistage amplifier, a number of single amplifier are connected in cascade arrangement . i.e. out of first stage is connected to the input of the second stage through a suitable coupling device and so on

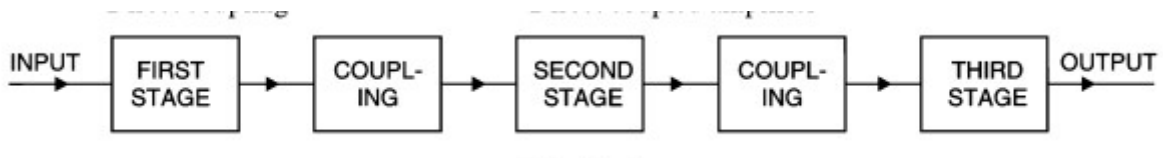

Type of coupling used:

1. R.C Coupling
2. Transformer coupling
3. Direct coupling

6.10.1 R.C. coupled amplifier:

The constructional details of a two-stage RC coupled transistor amplifier circuit is shown in below

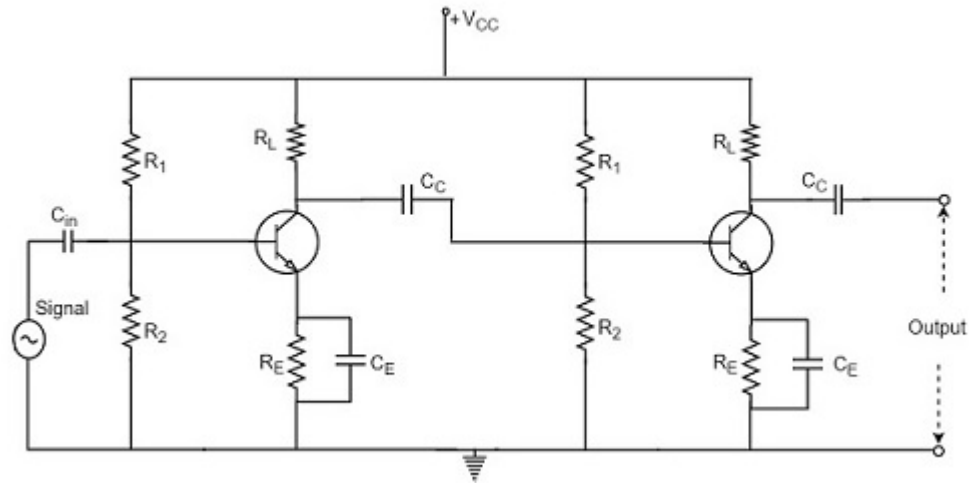

The two stage amplifier circuit has two transistors, connected in CE configuration and a common power supply V_{CC} is used. The potential divider network R_1 and R_2 and the resistor R_e form the biasing and stabilization network. The emitter by-pass capacitor C_e offers a low reactance path to the signal.

The resistor R_L is used as a load impedance. The input capacitor C_{in} present at the initial stage of the amplifier couples AC signal to the base of the transistor. The capacitor C_c is the coupling capacitor that connects two stages and prevents DC interference between the stages and controls the shift of operating point. The figure below shows the circuit diagram of RC coupled amplifier.

Operation of RC Coupled Amplifier

When an AC input signal is applied to the base of first transistor, it gets amplified and appears at the collector load R_L which is then passed through the coupling capacitor C_c to the next stage.

This becomes the input of the next stage, whose amplified output again appears across its collector load. Thus the signal is amplified in stage by stage action.

The important point that has to be noted here is that the total gain is less than the product of the gains of individual stages. This is because when a second stage is made to follow the first stage, the **effective load resistance** of the first stage is reduced due to the shunting effect of the input resistance of the second stage. Hence, in a multistage amplifier, only the gain of the last stage remains unchanged.

As we consider a two stage amplifier here, the output phase is same as input. Because the phase reversal is done two times by the two stage CE configured amplifier circuit.

Frequency Response of RC Coupled Amplifier

Frequency response curve is a graph that indicates the relationship between voltage gain and function of frequency. The frequency response of a RC coupled amplifier is as shown in the following graph.

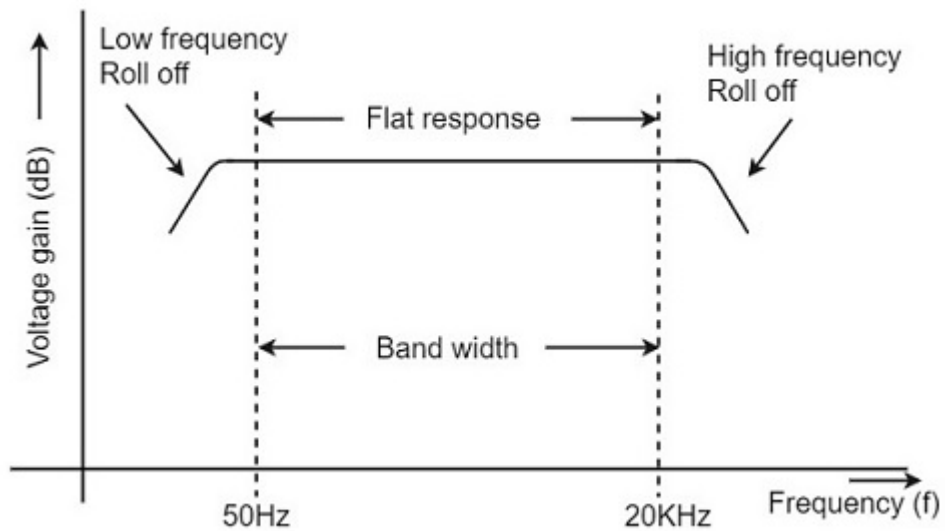

From the above graph, it is understood that the frequency rolls off or decreases for the frequencies below 50Hz and for the frequencies above 20 KHz. whereas the voltage gain for the range of frequencies between 50Hz and 20 KHz is constant.

At Low frequencies (i.e. below 50 Hz)

The capacitive reactance is inversely proportional to the frequency. At low frequencies, the reactance is quite high. The reactance of input capacitor C_{in} and the coupling capacitor C_C are so high that only small part of the input signal is allowed. The reactance of the emitter by pass capacitor C_E is also very high during low frequencies. Hence it cannot shunt the emitter resistance effectively. With all these factors, the voltage gain rolls off at low frequencies.

At High frequencies (i.e. above 20 KHz)

Again considering the same point, we know that the capacitive reactance is low at high frequencies. So, a capacitor behaves as a short circuit, at high frequencies. As a result of this, the loading effect of the next stage increases, which reduces the voltage gain. Along with this, as the capacitance of emitter diode decreases, it increases the base current of the transistor due to which the current gain (β) reduces. Hence the voltage gain rolls off at high frequencies.

At Mid-frequencies (i.e. 50 Hz to 20 KHz)

The voltage gain of the capacitors is maintained constant in this range of frequencies, as shown in figure. If the frequency increases, the reactance of the capacitor CC decreases which tends to increase the gain. But this lower capacitance reactive increases the loading effect of the next stage by which there is a reduction in gain.

Due to these two factors, the gain is maintained constant.

Disadvantages of RC Coupled Amplifier

The following are the disadvantages of RC coupled amplifier.

- The voltage and power gain are low because of the effective load resistance.
- They become noisy with age.
- Due to poor impedance matching, power transfer will be **low**.

Applications of RC Coupled Amplifier

The following are the applications of RC coupled amplifier.

- They have excellent audio fidelity over a wide range of frequency.
- Widely used as Voltage amplifiers
- Due to poor impedance matching, RC coupling is rarely used in the final stages.

6.10.2 Transformer coupled amplifier

When they are coupled to make a multistage amplifier, the high output impedance of one stage comes in parallel with the low input impedance of next stage. Hence, effective load resistance is decreased. This problem can be overcome by a transformer coupled amplifier.

In a transformer-coupled amplifier, the stages of amplifier are coupled using a transformer. Let us go into the constructional and operational details of a transformer coupled amplifier.

Construction of Transformer Coupled Amplifier

The amplifier circuit in which, the previous stage is connected to the next stage using a coupling transformer, is called as Transformer coupled amplifier.

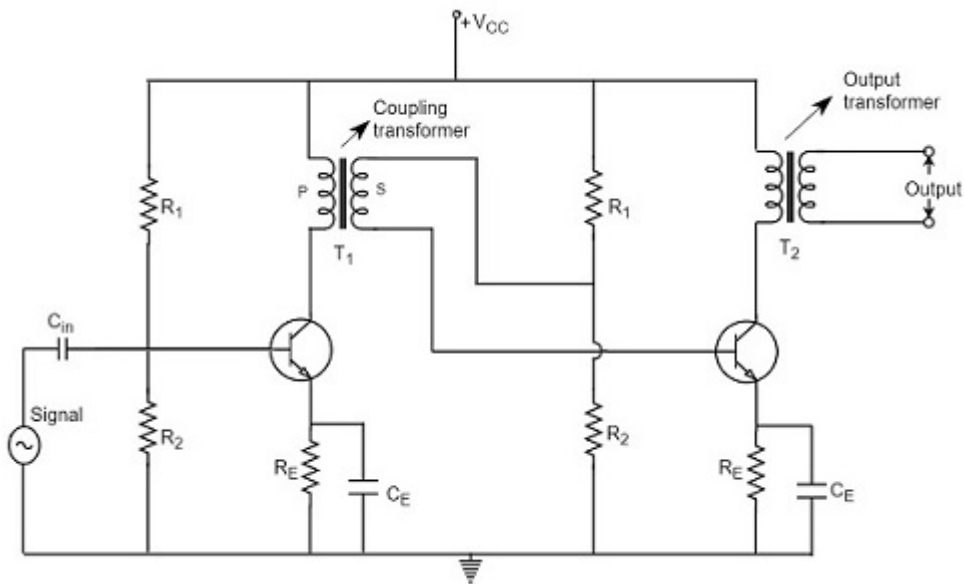

The coupling transformer T_1 is used to feed the output of 1st stage to the input of 2nd stage. The collector load is replaced by the primary winding of the transformer. The secondary winding is connected between the potential divider and the base of 2nd stage, which provides the input to the 2nd stage. Instead of coupling capacitor like in RC coupled amplifier, a transformer is used for coupling any two stages, in the transformer coupled amplifier circuit.

The potential divider network R_1 and R_2 and the resistor R_E together form the biasing and stabilization network. The emitter by-pass capacitor C_E offers a low reactance path to the signal. The resistor R_L is used as a load impedance. The input capacitor C_{in} present at the initial stage of the amplifier couples AC signal to the base of the transistor. The capacitor C_C is the coupling capacitor that connects two stages and prevents DC interference between the stages and controls the shift of operating point.

Operation of Transformer Coupled Amplifier

When an AC signal is applied to the input of the base of the first transistor then it gets amplified by the transistor and appears at the collector to which the primary of the transformer is connected.

The transformer which is used as a coupling device in this circuit has the property of impedance changing, which means the low resistance of a stage (or load) can be reflected as a high load resistance to the previous stage. Hence the voltage at the primary is transferred according to the turns ratio of the secondary winding of the transformer.

This transformer coupling provides good impedance matching between the stages of amplifier. The transformer coupled amplifier is generally used for power amplification.

Frequency Response of Transformer Coupled Amplifier

The figure below shows the frequency response of a transformer coupled amplifier. The gain of the amplifier is constant only for a small range of frequencies. The output voltage is equal to the collector current multiplied by the reactance of primary.

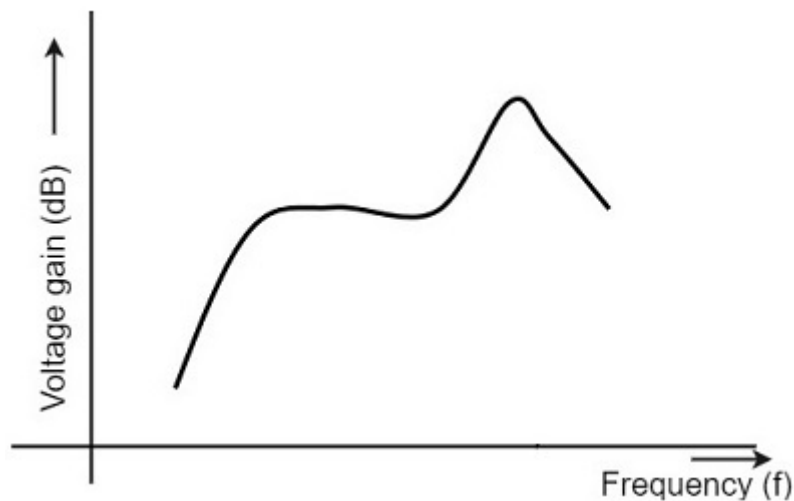

At low frequencies, the reactance of primary begins to fall, resulting in decreased gain. At high frequencies, the capacitance between turns of windings acts as a bypass condenser to reduce the output voltage and hence gain.

So, the amplification of audio signals will not be proportionate and some distortion will also get introduced, which is called as Frequency distortion.

Advantages of Transformer Coupled Amplifier

The following are the advantages of a transformer coupled amplifier –

- An excellent impedance matching is provided.
- Gain achieved is higher.
- There will be no power loss in collector and base resistors.
- Efficient in operation.

Disadvantages of Transformer Coupled Amplifier

The following are the disadvantages of a transformer coupled amplifier –

- Though the gain is high, it varies considerably with frequency. Hence a poor frequency response.
- Frequency distortion is higher.
- Transformers tend to produce hum noise.
- Transformers are bulky and costly.

Applications

The following are the applications of a transformer coupled amplifier –

- Mostly used for impedance matching purposes.
- Used for Power amplification.
- Used in applications where maximum power transfer is needed.

6.11 Feed back in amplifier

The process of injecting a fraction of output energy of some device back to the input is known as Feedback

Principle of Feedback Amplifier

A feedback amplifier generally consists of two parts. They are the **amplifier** and the **feedback circuit**.

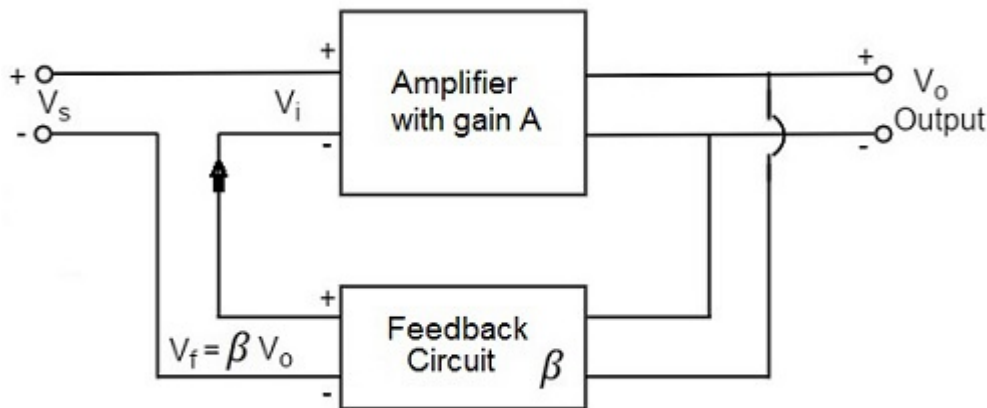

From the above figure, the gain of the amplifier is represented as A. the gain of the amplifier is the ratio of output voltage V_o to the input voltage V_i . the feedback network extracts a voltage $V_f = \beta V_o$ from the output V_o of the amplifier.

This voltage is added for positive feedback and subtracted for negative. Let us consider the case of negative feedback. The output V_o must be equal to the input voltage $(V_s - \beta V_o)$ multiplied by the gain A of the amplifier. feedback, from the signal voltage V_s . Now,

$$V_i = V_s + V_f = V_s + \beta V_o \quad (\text{Positive feedback})$$

$$V_i = V_s - V_f = V_s - \beta V_o \quad (\text{Negative Feed back})$$

The quantity $\beta = V_f/V_o$ is called as feedback ratio or feedback fraction.

Let us consider the case of negative feedback. The output V_o must be equal to the input voltage $(V_s - \beta V_o)$ multiplied by the gain A of the amplifier.

Hence,

$$(V_s - \beta V_o)A = V_o$$

Or

$$AV_s - A\beta V_o = V_o$$

OR

$$AV_s = V_o(1 + A\beta)$$

Therefore,

$$\frac{V_o}{V_s} = \frac{1}{1 + A\beta}$$

Let A_f be the overall gain (gain with the feedback) of the amplifier. This is defined as the ratio of output voltage V_o to the applied signal voltage V_s , i.e.,

$$A_f = \frac{\text{Output voltage}}{\text{Input signal voltage}} = \frac{V_o}{V_s}$$

So, from the above two equations, we can understand that,

The equation of gain of the feedback amplifier, with negative feedback is given by

$$A_f = \frac{A}{1 + A\beta}$$

The equation of gain of the feedback amplifier, with positive feedback is given by

$$A_f = \frac{A}{1 - A\beta}$$

Negative Feedback

The feedback in which the feedback energy i.e., either voltage or current is out of phase with the input and thus opposes it, is called as **negative feedback**.

In negative feedback, the amplifier introduces a phase shift of 180° into the circuit while the feedback network is so designed that it produces no phase shift or zero phase shift. Thus the resultant feedback voltage V_f is 180° out of phase with the input signal V_{in} .

Though the **gain** of negative feedback amplifier is **reduced**, there are many advantages of negative feedback such as

- Stability of gain is improved
- Reduction in distortion
- Reduction in noise
- Increase in input impedance
- Decrease in output impedance
- Increase in the range of uniform application

It is because of these advantages negative feedback is frequently employed in amplifiers.

There are two main types of negative feedback circuits. They are –

- Negative Voltage Feedback
- Negative Current Feedback

Negative Voltage Feedback

In this method, the voltage feedback to the input of amplifier is proportional to the output voltage. This is further classified into two types –

- Voltage-series feedback
- Voltage-shunt feedback

Negative Current Feedback

In this method, the voltage feedback to the input of amplifier is proportional to the output current. This is further classified into two types.

- Current-series feedback
- Current-shunt feedback

Voltage-Series Feedback

In the voltage series feedback circuit, a fraction of the output voltage is applied in series with the input voltage through the feedback circuit. This is also known as **shunt-driven series-fed** feedback, i.e., a parallel-series circuit.

The following figure shows the block diagram of voltage series feedback, by which it is evident that the feedback circuit is placed in shunt with the output but in series with the input.

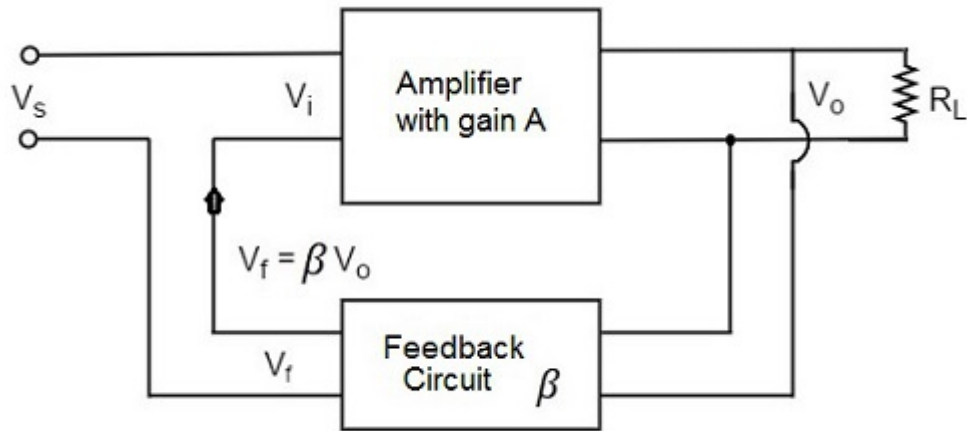

As the feedback circuit is connected in shunt with the output, the output impedance is decreased and due to the series connection with the input, the input impedance is increased.

Voltage-Shunt Feedback

In the voltage shunt feedback circuit, a fraction of the output voltage is applied in parallel with the input voltage through the feedback network. This is also known as **shunt-driven shunt-fed** feedback i.e., a parallel-parallel proto type.

The below figure shows the block diagram of voltage shunt feedback, by which it is evident that the feedback circuit is placed in shunt with the output and also with the input.

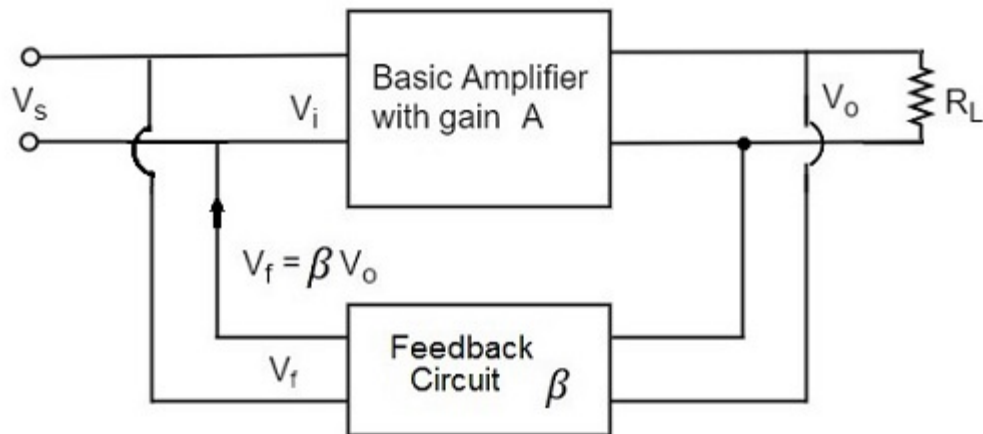

As the feedback circuit is connected in shunt with the output and the input as well, both the output impedance and the input impedance are decreased.

Current-Series Feedback

In the current series feedback circuit, a fraction of the output voltage is applied in series with the input voltage through the feedback circuit. This is also known as **series-driven series-fed** feedback i.e., a series-series circuit.

The following figure shows the block diagram of current series feedback, by which it is evident that the feedback circuit is placed in series with the output and also with the input.

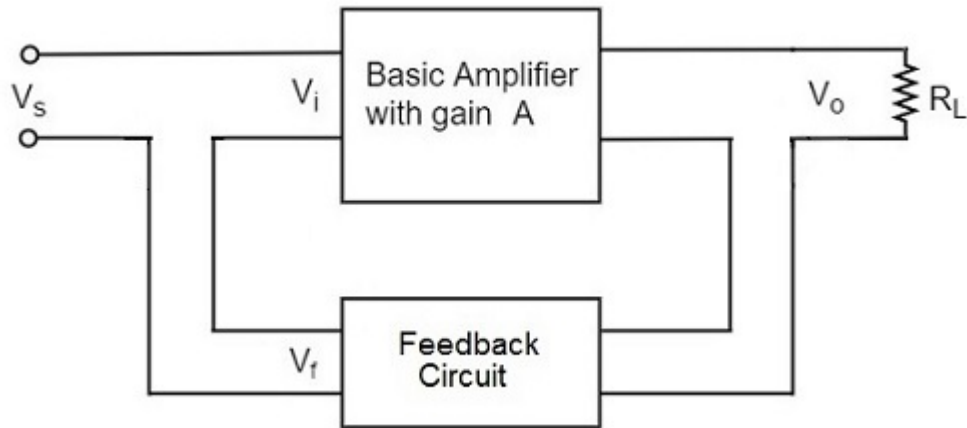

As the feedback circuit is connected in series with the output and the input as well, both the output impedance and the input impedance are increased.

Current-Shunt Feedback

In the current shunt feedback circuit, a fraction of the output voltage is applied in series with the input voltage through the feedback circuit. This is also known as **series-driven shunt-fed** feedback i.e., a series-parallel circuit.

The below figure shows the block diagram of current shunt feedback, by which it is evident that the feedback circuit is placed in series with the output but in parallel with the input.

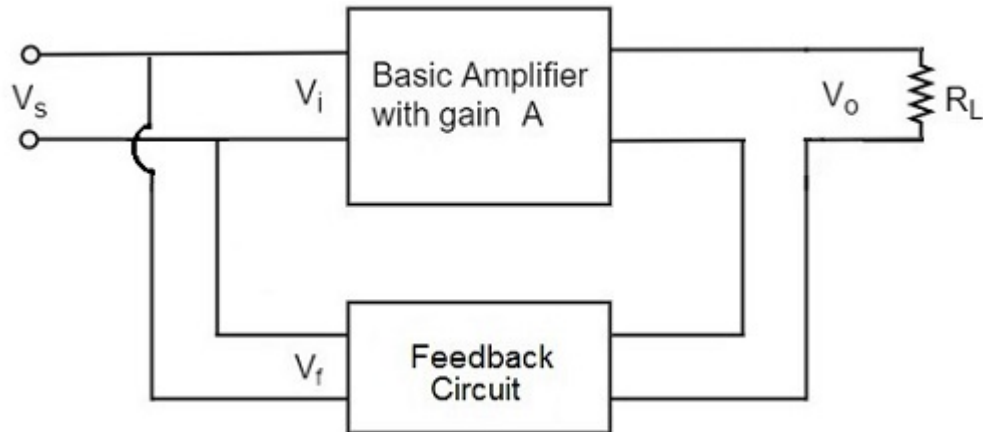

As the feedback circuit is connected in series with the output, the output impedance is increased and due to the parallel connection with the input, the input impedance is decreased.

6.12 Power amplifier and its classification

A transistor amplifier which raises the power level of the signals that have audio frequency range is known as Transistor audio power amplifier

After the audio signal is converted into electrical signal, it has several voltage amplifications done, after which the power amplification of the amplified signal is done just before the loud speaker stage. This is clearly shown in the below figure.

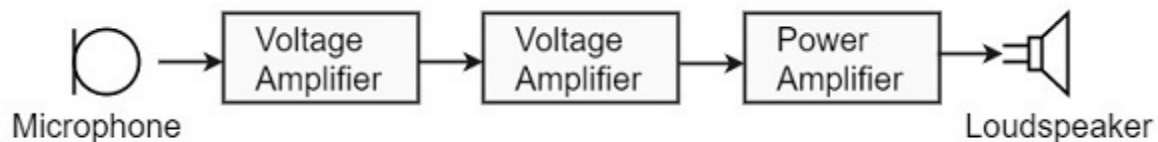

While the voltage amplifier raises the voltage level of the signal, the power amplifier raises the power level of the signal. Besides raising the power level, it can also be said that a power amplifier is a device which converts DC power to AC power and whose action is controlled by the input signal.

Classification Based on Frequencies

Power amplifiers are divided into two categories, based on the frequencies they handle. They are as follows.

- **Audio Power Amplifiers** – The audio power amplifiers raise the power level of signals that have audio frequency range (20 Hz to 20 KHz). They are also known as **Small signal power amplifiers**.
- **Radio Power Amplifiers** – Radio Power Amplifiers or tuned power amplifiers raise the power level of signals that have radio frequency range (3 KHz to 300 GHz). They are also known as **large signal power amplifiers**.

Classification Based on Mode of Operation

On the basis of the mode of operation, i.e., the portion of the input cycle during which collector current flows, the power amplifiers may be classified as follows.

- **Class A Power amplifier** – When the collector current flows at all times during the full cycle of signal, the power amplifier is known as **class A power amplifier**.
- **Class B Power amplifier** – When the collector current flows only during the positive half cycle of the input signal, the power amplifier is known as **class B power amplifier**.
- **Class C Power amplifier** – When the collector current flows for less than half cycle of the input signal, the power amplifier is known as **class C power amplifier**.

There forms another amplifier called Class AB amplifier, if we combine the class A and class B amplifiers so as to utilize the advantages of both.

Before going into the details of these amplifiers, let us have a look at the important terms that have to be considered to determine the efficiency of an amplifier.

6.12.1 Difference between voltage amplifier and power amplifier

Voltage Amplifier

The function of a voltage amplifier is to raise the voltage level of the signal. A voltage amplifier is designed to achieve maximum voltage amplification.

The voltage gain of an amplifier is given by

$$A_v = \beta \left(\frac{R_c}{R_{in}} \right)$$

The characteristics of a voltage amplifier are as follows –

- The base of the transistor should be thin and hence the value of β should be greater than 100.
- The resistance of the input resistor R_{in} should be low when compared to collector load R_c .
- The collector load R_c should be relatively high. To permit high collector load, the voltage amplifiers are always operated at low collector current.
- The voltage amplifiers are used for small signal voltages.

Power Amplifier

The function of a power amplifier is to raise the power level of input signal. It is required to deliver a large amount of power and has to handle large current.

The characteristics of a power amplifier are as follows –

- The base of transistor is made thicken to handle large currents. The value of β being ($\beta < 100$)

- The size of the transistor is made larger, in order to dissipate more heat, which is produced during transistor operation.
- Transformer coupling is used for impedance matching.
- Collector resistance is made low.

6.12.2 Transformer coupled class A power amplifier

The circuit in which the output current flows for the entire cycle of the AC input supply. it has such as low output power and efficiency. In order to minimize those effects, the transformer coupled class A power amplifier has been introduced.

The **construction of class A power amplifier** can be understood with the help of below figure. This is similar to the normal amplifier circuit but connected with a transformer in the collector load.

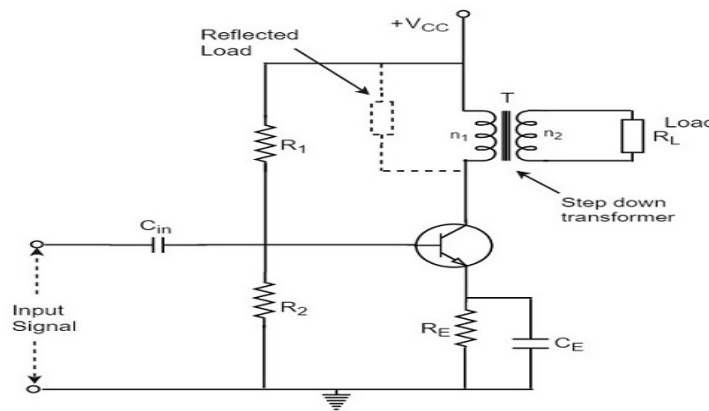

Here R_1 and R_2 provide potential divider arrangement. The resistor R_e provides stabilization, C_e is the bypass capacitor and R_e to prevent a.c. voltage. The transformer used here is a step-down transformer.

The high impedance primary of the transformer is connected to the high impedance collector circuit. The low impedance secondary is connected to the load (generally loud speaker).

Transformer Action

The transformer used in the collector circuit is for impedance matching. R_L is the load connected in the secondary of a transformer. R_L' is the reflected load in the primary of the transformer.

The number of turns in the primary are n_1 and the secondary are n_2 . Let V_1 and V_2 be the primary and secondary voltages and I_1 and I_2 be the primary and secondary currents respectively. The below figure shows the transformer clearly.

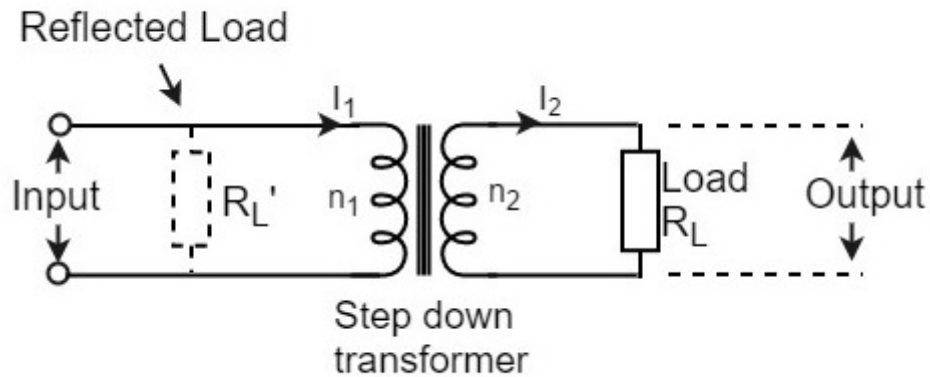

Circuit Operation

If the peak value of the collector current due to signal is equal to zero signal collector current, then the maximum a.c. power output is obtained. So, in order to achieve complete amplification, the operating point should lie at the center of the load line.

The operating point obviously varies when the signal is applied. The collector voltage varies in opposite phase to the collector current. The variation of collector voltage appears across the primary of the transformer.

Advantages

The advantages of transformer coupled class A power amplifier are as follows.

- No loss of signal power in the base or collector resistors.
- Excellent impedance matching is achieved.
- Gain is high.
- DC isolation is provided.

Applications

The applications of transformer coupled class A power amplifier are as follows.

- This circuit is where impedance matching is the main criterion.
- These are used as driver amplifiers and sometimes as output amplifiers.

6.12.3 Class A push – pull amplifier

It is possible to obtain greater power output and efficiency than that of the Class A amplifier by using a combinational transistor pair called as **Push-Pull** configuration.

In this circuit, we use two complementary transistors in the output stage with one transistor being an NPN or N-channel type while the other transistor is a PNP or P-channel (the complement) type connected in order to operate them like **PUSH a transistor to ON** and **PULL another transistor to OFF** at the same time. This push-pull configuration can be made in class A, class B, class C or class AB amplifiers.

Construction of Push-Pull Class A Power Amplifier

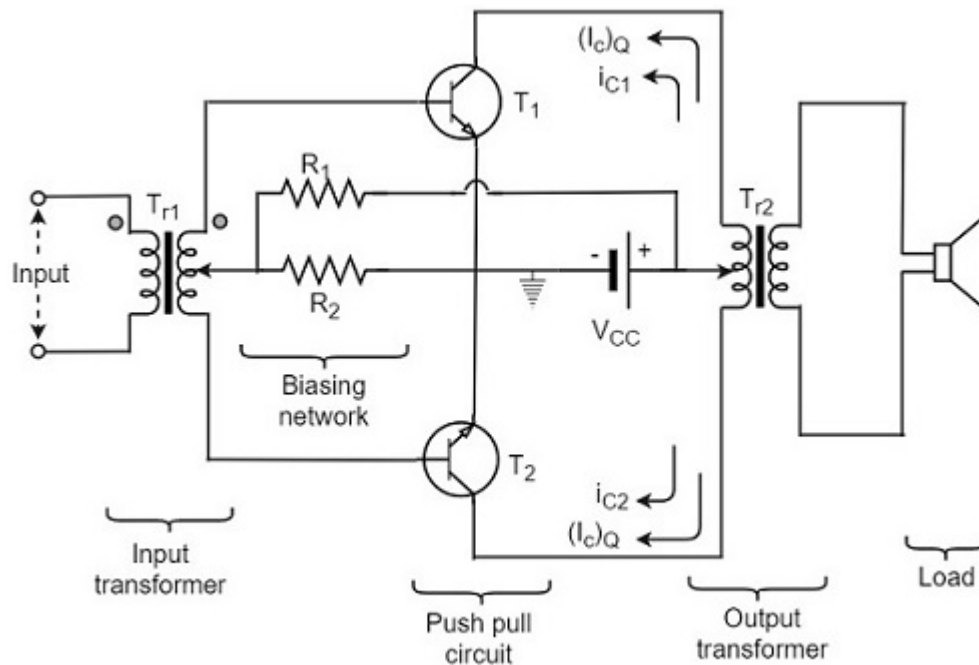

The construction of the class A power amplifier circuit in push-pull configuration is shown as in the figure below. This arrangement mainly reduces the harmonic distortion introduced by the non-linearity of the transfer characteristics of a single transistor amplifier.

In Push-pull arrangement, the two identical transistors T_1 and T_2 have their emitter terminals shorted. The input signal is applied to the transistors through the transformer T_{r1} which provides opposite polarity signals to both the transistor bases. The collectors of both the transistors are connected to the primary of output transformer T_{r2} . Both the transformers are center tapped. The V_{cc} supply is provided to the collectors of both the transistors through the primary of the output transformer.

The resistors R_1 and R_2 provide the biasing arrangement. The load is generally a loudspeaker which is connected across the secondary of the output transformer. The turns ratio of the output transformer is chosen in such a way that the load is well matched with the output impedance of the transistor. So maximum power is delivered to the load by the amplifier.

Circuit Operation

The output is collected from the output transformer T_{r2} . The primary of this transformer T_{r2} has practically no dc component through it. The transistors T_1 and T_2 have their collectors connected to the primary of transformer T_{r2} so that their currents are equal in magnitude and flow in opposite directions through the primary of transformer T_{r2} .

When the a.c. input signal is applied, the base of transistor T_1 is more positive while the base of transistor T_2 is less positive. Hence the collector current i_{c1} of transistor T_1 increases while the collector current i_{c2} of transistor T_2 decreases. These currents flow in opposite directions in two halves of the primary of output transformer. Moreover, the flux produced by these currents will also be in opposite directions.

Hence, the voltage across the load will be induced voltage whose magnitude will be proportional to the difference of collector currents i.e.

$$(i_{c1} - i_{c2})$$

Similarly, for the negative input signal, the collector current i_{c2} will be more than i_{c1} . In this case, the voltage developed across the load will again be due to the difference

$$(i_{c1} - i_{c2})$$

$$\text{As } i_{c2} > i_{c1}$$

The polarity of voltage induced across load will be reversed.

$$i_{c1} - i_{c2} = i_{c1} + (-i_{c2})$$

To have a better understanding, let us consider the below figure.

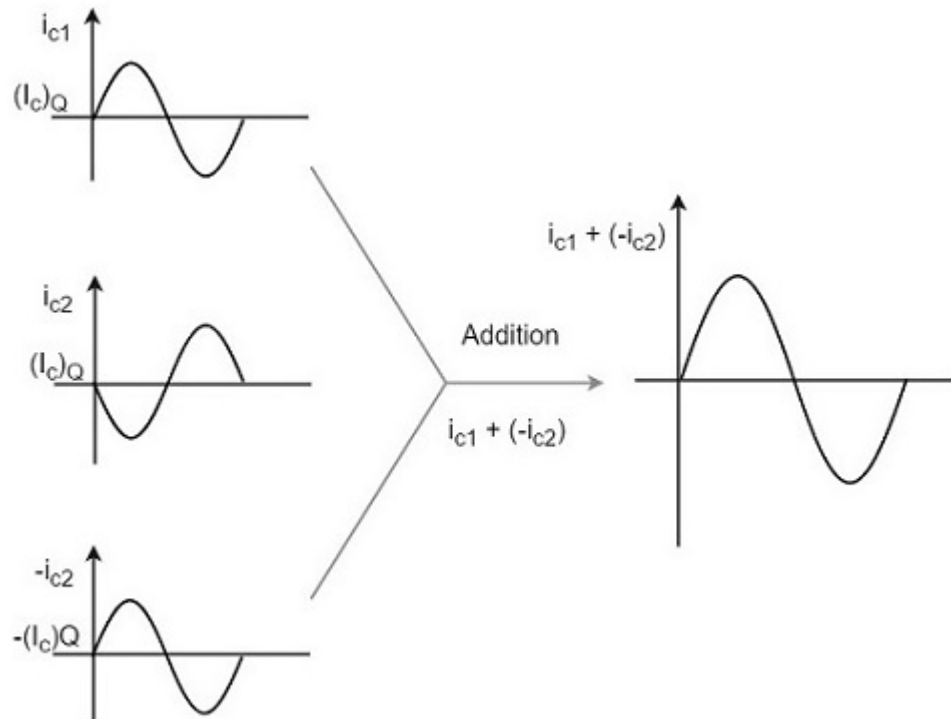

The overall operation results in an a.c. voltage induced in the secondary of output transformer and hence a.c. power is delivered to that load.

It is understood that, during any given half cycle of input signal, one transistor is being driven (or pushed) deep into conduction while the other being non-conducting (pulled out). Hence the name **Push-pull amplifier**. The harmonic distortion in Push-pull amplifier is minimized such that all the even harmonics are eliminated.

Advantages

The advantages of class A Push-pull amplifier are as follows

- High a.c. output is obtained.
- The output is free from even harmonics.
- The effect of ripple voltages are balanced out. These are present in the power supply due to inadequate filtering.

Disadvantages

The disadvantages of class A Push-pull amplifier are as follows

- The transistors are to be identical, to produce equal amplification.

- Center-tapping is required for the transformers.
- The transformers are bulky and costly.

6.12.4 Class B push – pull amplifier

Though the efficiency of class B power amplifier is higher than class A, as only one half cycle of the input is used, the distortion is high. Also, the input power is not completely utilized. In order to compensate these problems, the push-pull configuration is introduced in class B amplifier.

Construction

The circuit of a push-pull class B power amplifier consists of two identical transistors T_1 and T_2 whose bases are connected to the secondary of the center-tapped input transformer T_{r1} . The emitters are shorted and the collectors are given the V_{CC} supply through the primary of the output transformer T_{r2} .

The circuit arrangement of class B push-pull amplifier, is same as that of class A push-pull amplifier except that the transistors are biased at cut off, instead of using the biasing resistors. The figure below gives the detailing of the construction of a push-pull class B power amplifier.

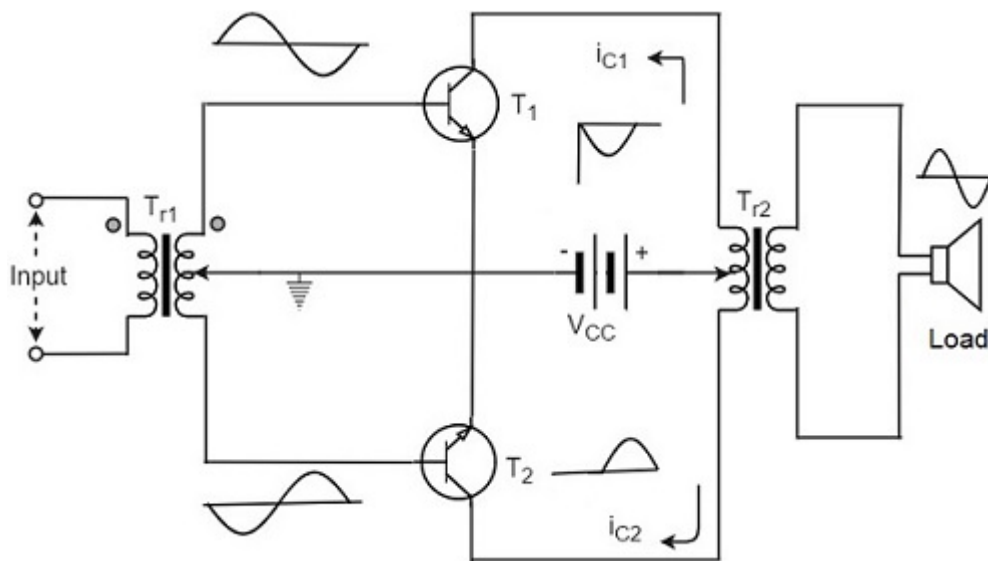

Operation

The circuit of class B push-pull amplifier shown in the above figure clears that both the transformers are center-tapped. When no signal is applied at the input, the transistors T_1 and T_2 are in cut off condition and hence no collector currents flow. As no current is drawn from V_{CC} , no power is wasted.

When input signal is given, it is applied to the input transformer T_{r1} which splits the signal into two signals that are 180° out of phase with each other. These two signals are given to the two identical transistors T_1 and T_2 . For the positive half cycle, the base of the transistor

T₁ becomes positive and collector current flows. At the same time, the transistor T₂ has negative half cycle, which throws the transistor T₂ into cutoff condition and hence no collector current flows.

For the next half cycle, the transistor T₁ gets into cut off condition and the transistor T₂ gets into conduction, to contribute the output. Hence for both the cycles, each transistor conducts alternately.

6.13 Oscillators

Oscillators are electronic circuits that generate a continuous periodic waveform at a precise frequency

Oscillators convert a DC input (the supply voltage) into an AC output (the waveform)

Oscillators are used in many pieces of test equipment producing either sinusoidal sine waves, square, sawtooth or triangular shaped waveforms or just a train of repetitive pulses of a variable or constant width.

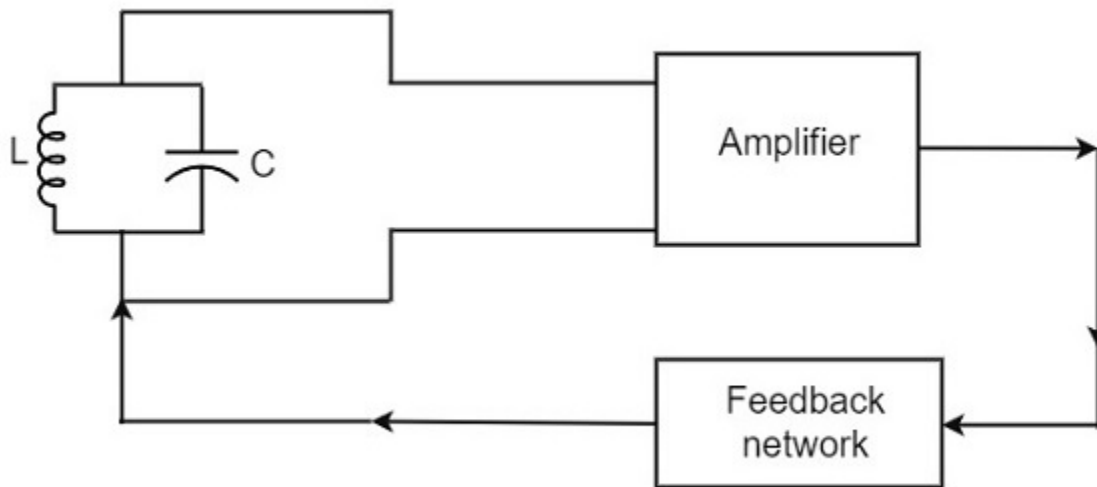

Oscillator circuit consists of a tank circuit, a transistor amplifier, and a feedback circuit.

- **Tank Circuit** – The tank circuit consists of an inductance L connected in parallel with capacitor C. The values of these two components determine the frequency of the oscillator circuit and hence this is called as **Frequency determining circuit**.
- **Transistor Amplifier** – The output of the tank circuit is connected to the amplifier circuit so that the oscillations produced by the tank circuit are amplified here. Hence the output of these oscillations are increased by the amplifier.
- **Feedback Circuit** – The function of feedback circuit is to transfer a part of the output energy to LC circuit in proper phase. This feedback is positive in oscillators while negative in amplifiers.

6.13.1 Types of oscillators

FIELD EFFECT TRANSISTOR:

A Field Effect Transistor (FET) is a three-terminal semiconductor device. Its operation is based on a controlled input voltage

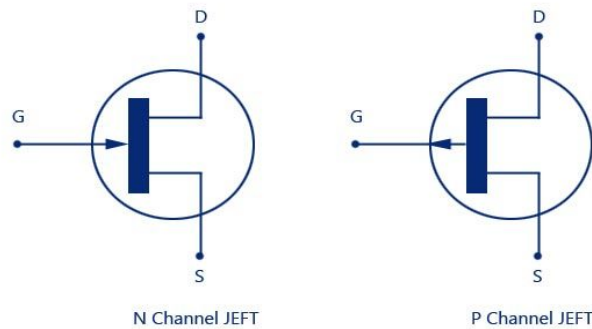

JFET-N-Channel and P-channel Schematic Symbol

- FET is low noise device
- FET is normally used in high impedance requirement
- It can be used as an amplifier or switch
- Its operation depends upon the flow of majority carrier (i.e. Either electron or holes)
- It is a voltage controlled device whose output drain current (I_D) can be controlled by applied input voltage between Gate and source terminal.

Terminal details of JFET:

- **Source** – It is the entry point for majority carriers through which they enter into the semiconductor bar.
- **Drain** – It is the exit point for majority carriers through which they leave the semiconductor bar.
- **Gate** – The two P-region are internally connected and a single lead is brought out this is called Gate terminal.
- **Channel** – It is the area of N type material through which majority carriers pass from the source to drain.

Classification of Field effect Transistor (FET)

Most commonly two types of FETs are available.

- Junction Field Effect Transistor (JFET)
- Metal Oxide Semiconductor FET (IGFET)

Further Junction Field Effect Transistor (JFET) are two type **N-Channel JFET** and **P-Channel JFET**.

N-Channel JFET

It has a thin layer of N type material formed on P type substrate. Following figure shows the crystal structure and schematic symbol of an N-channel JFET. Then the gate is formed on top of the N channel with P type material. At the end of the channel and the gate, lead wires are attached and the substrate has no connection.

When a DC voltage source is connected to the source and the drain leads of a JFET, maximum current will flow through the channel. The same amount of current will flow from the source and the drain terminals. The amount of channel current flow will be determined by the value of V_{DD} and the internal resistance of the channel.

A typical value of source-drain resistance of a JFET is quite a few hundred ohms. It is clear that even when the gate is open full current conduction will take place in the channel. Essentially, the amount of bias voltage applied at I_D , controls the flow of current carriers passing through the channel of a JFET. With a small change in gate voltage, JFET can be controlled anywhere between full conduction and cutoff state.

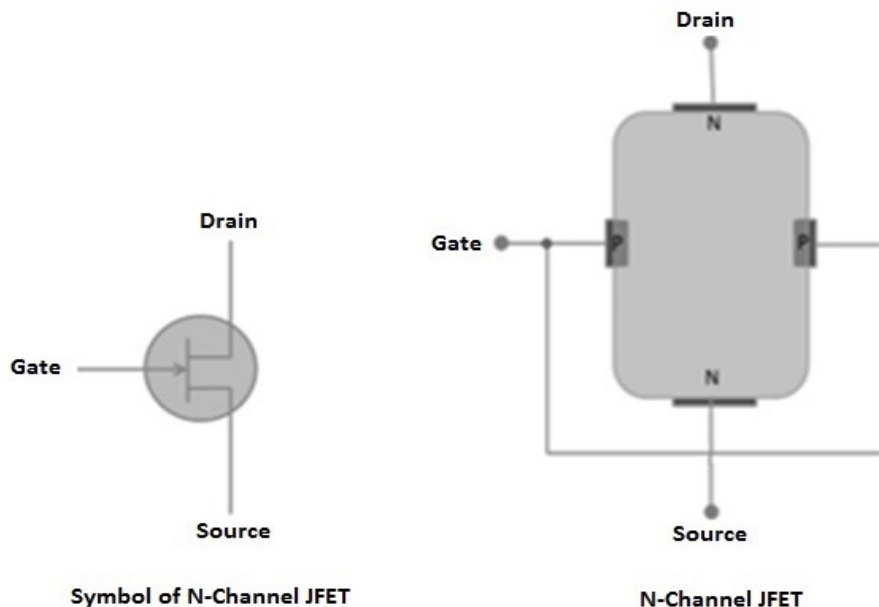

P-Channel JFETs

It has a thin layer of P type material formed on N type substrate. The following figure shows the crystal structure and schematic symbol of an N-channel JFET. The gate is formed on top of the P channel with N type material. At the end of the channel and the gate, lead wires are attached. Rest of the construction details are similar to that of N-channel JFET.

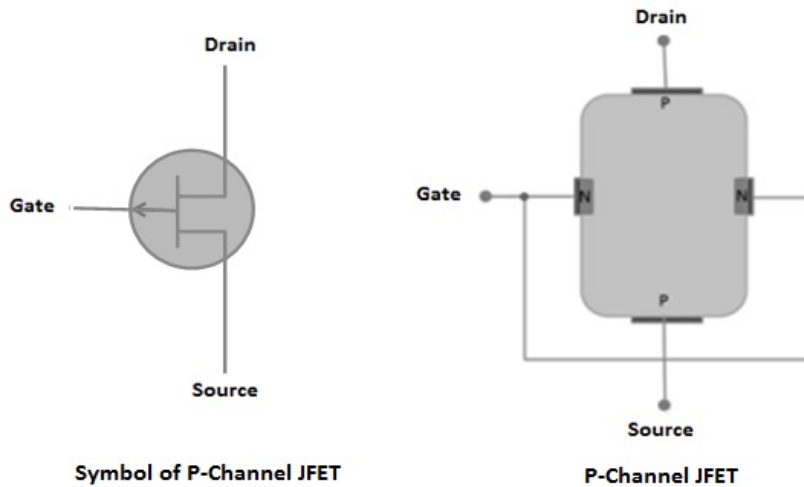

Normally for general operation, the gate terminal is made positive with respect to the source terminal. The size of the P-N junction depletion layer depends upon fluctuations in the values of reverse biased gate voltage. With a small change in gate voltage, JFET can be controlled anywhere between full conduction and cutoff state.

Output Characteristics of JFET

The output characteristics of JFET are drawn between drain current (I_D) and drain source voltage (V_{DS}) at constant gate source voltage (V_{GS}) as shown in the following figure.



Initially, the drain current (I_D) rises rapidly with drain source voltage (V_{DS}) however suddenly becomes constant at a voltage known as pinch-off voltage (V_P). Above pinch-off voltage, the channel width becomes so narrow that it allows very small drain current to pass through it. Therefore, drain current (I_D) remains constant above pinch-off voltage.

Parameters of JFET

The main parameters of JFET are –

- AC drain resistance (R_d)
- Transconductance
- Amplification factor

AC drain resistance (R_d): – It is the ratio of change in the drain source voltage (ΔV_{DS}) to the change in drain current (ΔI_D) at constant gate-source voltage. It can be expressed as,

$$R_d = (\Delta V_{DS})/(\Delta I_D) \text{ at Constant } V_{GS}$$

Transconductance (g_{fs}) – It is the ratio of change in drain current (ΔI_D) to the change in gate source voltage (ΔV_{GS}) at constant drain-source voltage. It can be expressed as,

$$g_{fs} = (\Delta I_D)/(\Delta V_{GS}) \text{ at constant } V_{DS}$$

Amplification Factor (u) – It is the ratio of change in drain-source voltage (ΔV_{DS}) to the change in gate source voltage (ΔV_{GS}) constant drain current (ΔI_D). It can be expressed as,

$$u = (\Delta V_{DS})/(\Delta V_{GS}) \text{ at constant } I_D$$