

GOVERNMENT POLYTECHNIC, NAYAGARH

ELECTRONICS ENGINEERING

Analog Electronics Laboratory Manual

Prepared By : Er. Kumar Avisek

DEPARTMENT OF ELECTRICAL ENGINEERING



LABORATORY MANUAL Analog Electronics Lab

(4th Semester)

Govt. Polytechnic, Nayagarh

At - Ghasadeipur, Po - Nandighore

Pin - 752081

Prepared By : Er. Kumar Avisek

Lab. Asst. (A. E. & I.)

TABLE OF CONTENTS

Sl. No	Name of the Experiment	Pages
1	Determine the input and output Characteristics of CE & CB transistor configuration	3-8
2	Determine Drain & Transfer Characteristics of JFET	9-11
3	Construct Bridge Rectifier using different filter circuit and to determine Ripple factor & analyze wave form with filter & without filter.	12-17
4	Construct Bridge Rectifier using different filter and to determine Ripple factor	18-22
5	Construct & test the regulator using Zener diode	23-24
6	Construct different types of biasing circuit and analyze the wave form (i) Fixed bias (ii) Emitter bias (iii) Voltage divider bias	25-28
7	Study the single stage CE amplifier & find Gain	29-31
8	Study multi stage R-C coupled amplifier & to determine frequency-response & gain	32-34
9	Construct & Find the gain (I) Class A. Amplifier (ii) Class B. Amplifier (iii) Class C Tuned Amplifier	35-38
10	Construct & test push pull amplifier & observer the wave form	39-40
11	Construct & test push pull amplifier & observer the wave form shift oscillator and draw wave form & calculate the frequency	41-45
12	Construct & Test Differentiator and Integrator using R-C Circuit	46-48
13	Study Multivibrator (Astable, Bistable, Monstable) Circuit & Draw its Wave forms	49-53

Experiment - 01

Aim- Determine the input and output Characteristic of CE & CB transistor configuration.

APPARATUS REQUIRED:

Sl. No	Name of the Equipment	Specification	Quantity
1	Transistor	BC147	1no
2	Resistance	1k Ω	2 nos
3	Regulated Power Supply	0-30v	2 nos
4	Ammeter	0-30 mA	2 nos
5	Voltmeter	0-20 V	2 nos
6	Connecting Probes	-	As Per Required

Theory:-

Transistor:- Transistor is a semiconductor device that can both conduct and insulate. A transistor can act as a switch and an amplifier. It converts audio waves into electronic waves and resistor, controlling electronic current. Transistors have very long life, smaller in size, can operate on lower voltage supplies for greater safety and required no filament current. The first transistor was fabricated with germanium. A transistor performs the same function as a vacuum tube triode, but using semiconductor junctions instead of heated electrodes in a vacuum chamber. It is the fundamental building block of modern electronic devices and found everywhere in modern electronic systems.

A transistor is a three terminal device. Namely,

- Base: This is responsible for activating the transistor.
- Collector: This is the positive lead.
- Emitter: This is the negative lead.

Types of Transistors:

Bipolar Junction Transistor (BJT) has three terminals connected to three doped semiconductor regions. It comes with two types, P-N-P and N-P-N.

P-N-P transistor, consisting of a layer of N-doped semiconductor between two layers of P-doped material. The base current entering in the collector is amplified at its output.

That is when PNP transistor is ON when its base is pulled low relative to the emitter. The arrows of PNP transistor symbol the direction of current flow when the device is in forward active mode.

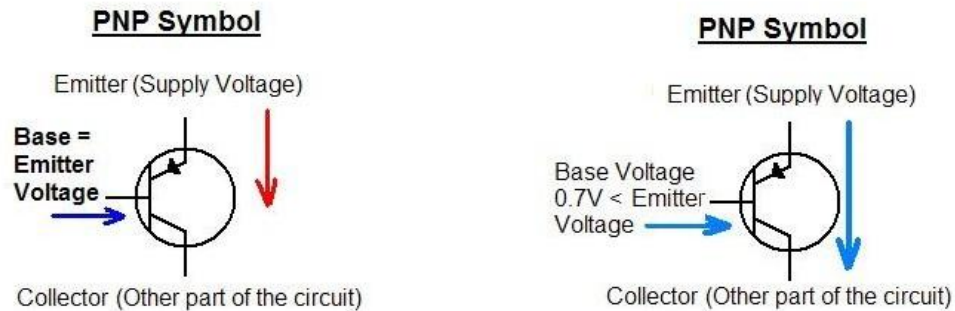
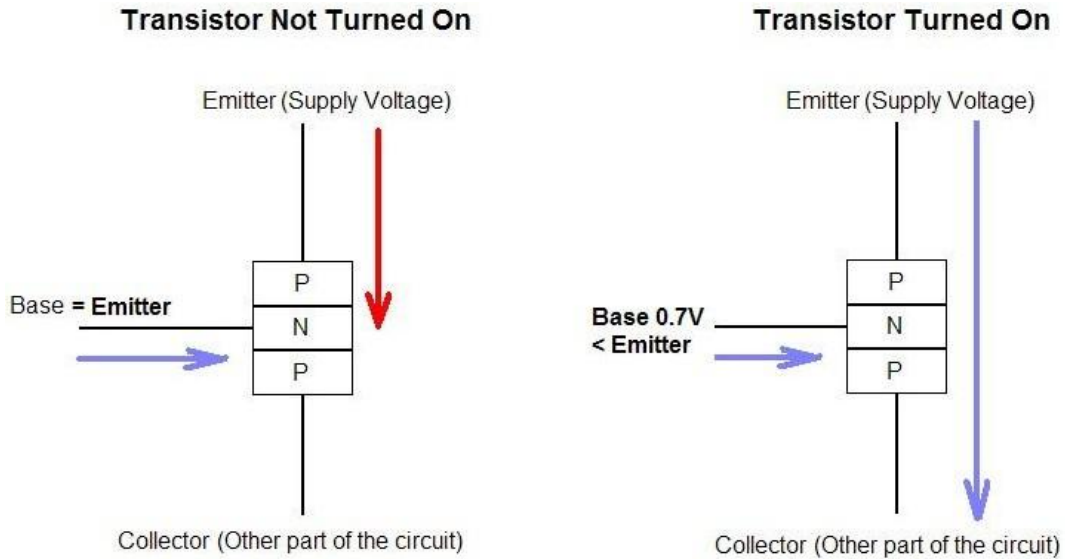

Transistor circuit configurations:-

The naming of the three basic transistor configurations indicates the transistor terminal that is common to both input and output circuits. This gives rise to the three terms: common base, common collector and common emitter.

The term grounded, i.e. grounded base, grounded collector and grounded emitter may also be used on occasions because the common element signal is normally grounded.

The three different transistor configurations are:

- **Common base:** This transistor configuration provides a low input impedance while offering a high output impedance. Although the voltage is high, the current gain is low and the overall power gain is also low when compared to the other transistor configurations available. The other salient feature of this configuration is that the input and output are in phase.

[Circuit Diagram of Common Base Configuration]

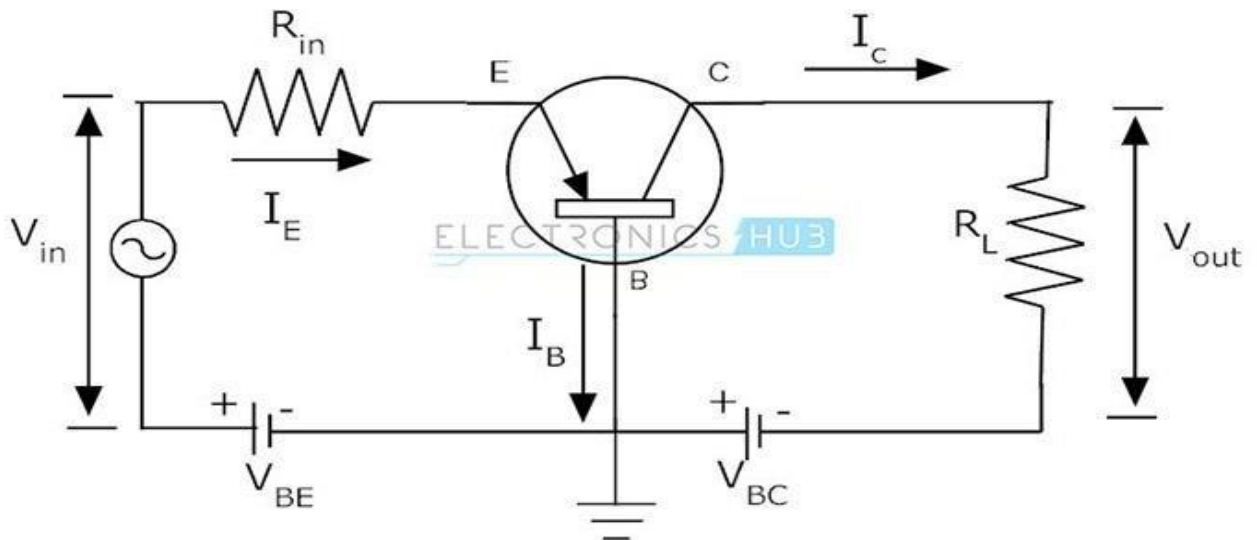

- **Common collector:** This transistor configuration is also known as the emitter follower because the emitter voltage follows that of the base. Offering high input impedance and a low output impedance it is widely used as a buffer. The voltage gain is unity, although current gain is high. The input and output signals are in phase.

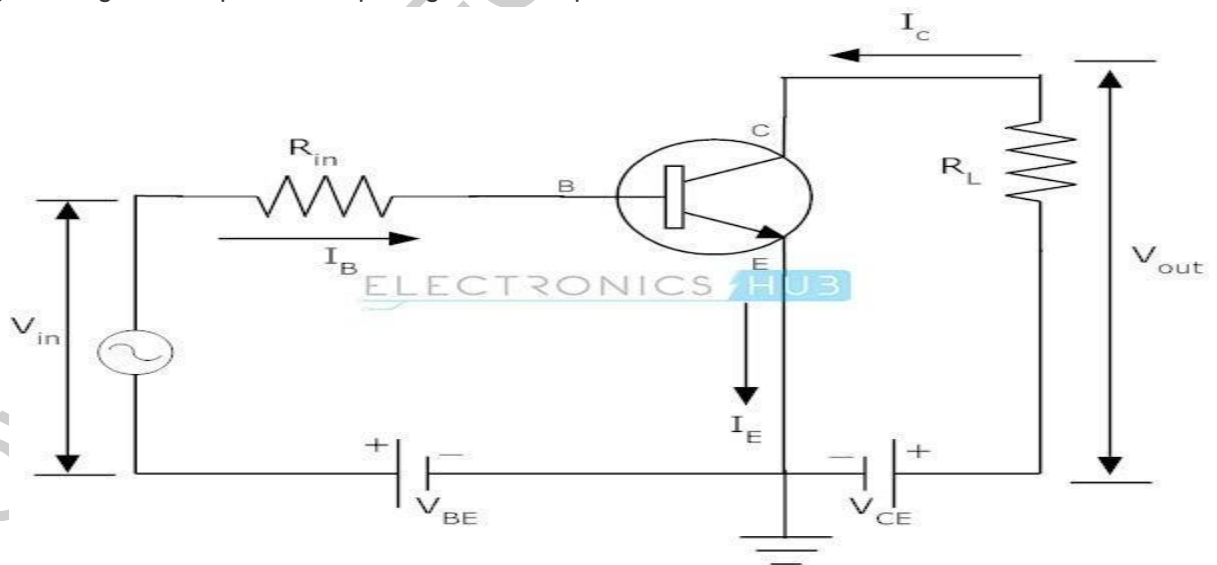

[Circuit Diagram of Common Collector Configuration]

Procedure:-

For CB Mode:-

Input Characteristic:-

- (a) Make the connection as per circuit diagram .
- (b) Switch „ON“ the supply & set $V = 0V$
- (c) Vary V in step & note down the emitter current I at each step .
- (d) Set $V = 1V$ & again repeat the same procedure .
- (e) Draw the graph.

Output characteristic:-

- (a) Make the connection as per circuit diagram.
- (b) Set the value of $I = 1m$
- (c) Vary V in step & note down the collector current I at each step.
- (d) Set $I = 2mA$ & repeat the same procedure.
- (e) Draw the graph.

For CE Mode:-

Input Characteristic:-

- a) Make the connection as per circuit diagram.
- b) Keep emitter - collector voltage constant.
- c) Vary emitter-base voltage in steps and note down base current reading.
- d) Readings are tabulated and graph is drawn.
- e) Draw the graph.

Output characteristics

- a) Make the connection as per circuit diagram.
- b) Keep base current constant.
- c) Vary collector-emitter voltage in steps and note down emitter current.
- d) Readings are tabulated and graph is drawn.
- e) Draw the graph.

Tabulation:-

Common Base Characteristic:-

Input characteristics i.e. $V_{EB}-I_E$ for constant V_{CB}

Sl. No	$V_{CB} = -2V$		$V_{CB} = -4V$		$V_{CB} = -6V$	
	V_{BE}	I_E in mA	V_{BE}	I_E in mA	V_{BE}	I_E in mA
1						
2						
3						
4						
5						
6						

Output characteristics i.e. $V_{CB}-I_C$ for constant I_E

Sl. No	$I_E = 10mA$		$I_E = 15mA$		$I_E = 20mA$	
	V_{CB}	I_C in mA	V_{CB}	I_C in mA	V_{CB}	I_C in mA
1						
2						
3						
4						
5						
6						

Graphs:-

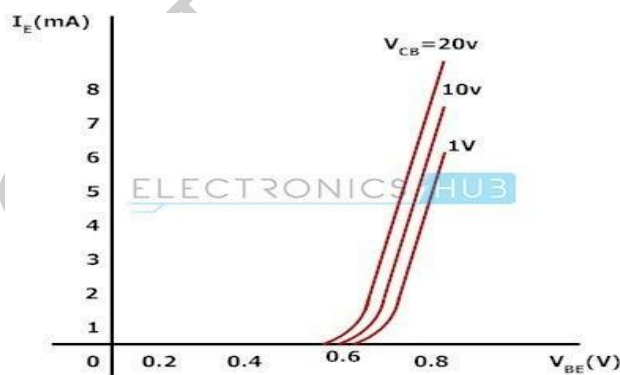

[Input Characteristic]

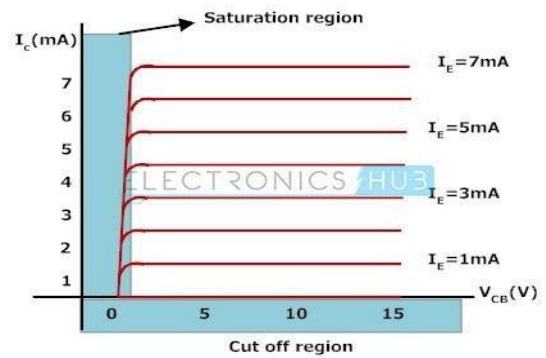

[Output Characteristic]

Common Emitter Characteristic:-

Input characteristics i.e. $V_{BE}-I_B$ for constant V_{CE}

	$V_{CE} = -2V$		$V_{CE} = -4V$		$V_{CE} = -6V$	
Sl. No	V_{BE}	I_B in mA	V_{BE}	I_E	V_{BE}	I_E
1						
2						
3						
4						
5						
6						

Output characteristics i.e. $V_{CE}-I_C$ for constant I_B

	$I_B = 50mA$		$I_B = 75mA$		$I_B = 100mA$	
Sl. No	V_{CE}	I_C in mA	V_{CE}	I_C in mA	V_{CE}	I_C in mA
1						
2						
3						
4						
5						
6						

Graphs:-

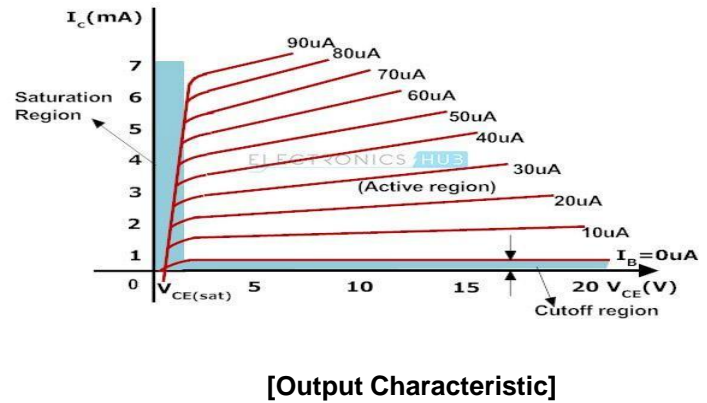
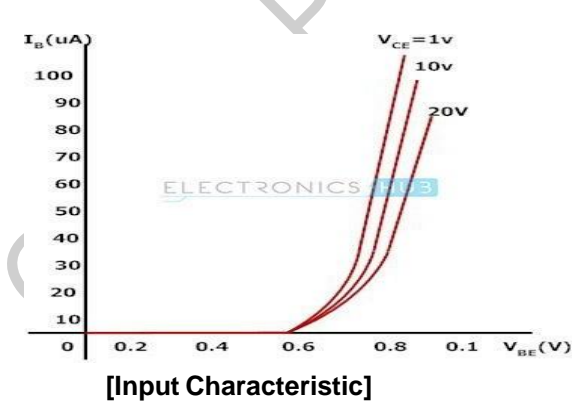

Conclusion:- From the above experiment, we learnt the input and output characteristic of CE & CB transistor configuration.

Experiment - 02

Aim- Determine Drain & transfer characteristics of JFET.

APPARATUS REQUIRED:-

Sl. No	Name of the Equipment	Specification	Quantity
1	JFET	BF4393	1 no
2	Regulated Power Supplies	0-30v	1 no
3	Voltmeter	0-20v	2 nos
4	Ammeter	0-100mA	1 no
5	Connecting Probes	-	As Per Required

Theory:-

The Junction Field Effect transistor (JFET) is one of the types of FET transistors. JFET is a simplest form of FET transistors and it has three terminals. The JFET transistors are used as electronically controlled switches, Voltage controlled resistors and as amplifiers.

BJT transistors are constructed with the PN-junctions but the JFET transistors have a channel instead of the PN-junctions. This channel is formed due to the either of P-type or N-type semiconductor materials.

The JFET transistors are classified into two types; they are N-channel JFET and P-channel JFET. In the N-channel JFET the channel is doped with the donor impurities due to this the current passing through the channel is negative (i.e. due to electrons) but in the P-channel JFETs the channel is doped with the acceptor impurities due to this the current flowing through this channel is positive (i.e. due to holes).

The N-channel JFET has more current conduction than P-channel JFET because the mobility of electrons is greater than the mobility of holes. So the N-channel JFETs are widely used than P-channel JFETs. The small voltage at the gate (G) terminal controls the current flow in the channel (between drain and source) of the JFET.

The emitter and collector terminals are connected using PN-junctions in BJT but in JFET the Drain and Source terminals are connected with the channel. The small voltage applied at the gate terminal controls the current flow in the channel between the drain and source of the JFET. This gate voltage is negative in N-channel JFET and it is positive in P-channel JFET.

One of the main differences between the BJT and JFET transistors is that when the JFET has reverse-biased junction, then the gate current may be zero, but in the BJT the base current always must be greater than zero.

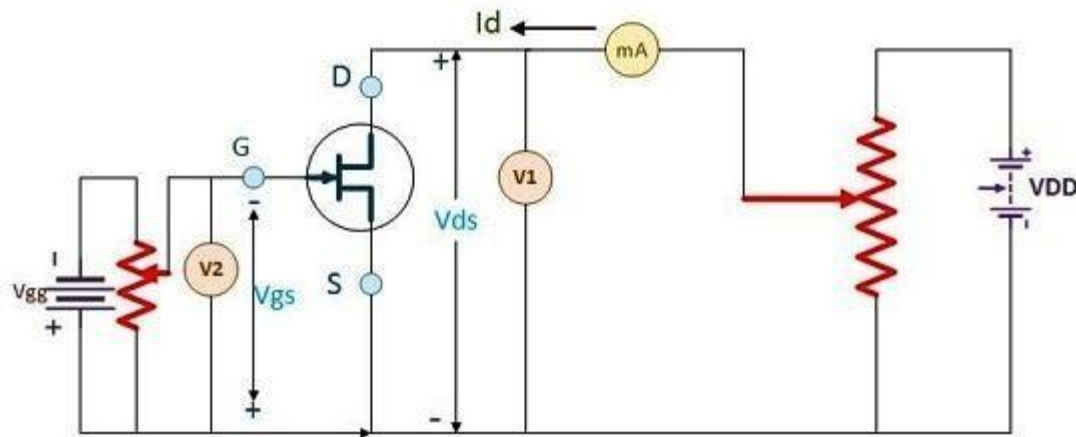

[Circuit Diagram of JFET]

Procedure:-

1. All the connections are made as per the connection & Circuit diagram.
2. Verify the connections, must be proper in all respect.
3. To plot the drain characteristics, keep V_{GS} Constant at 0V.
4. Vary the V_{DD} and observe the values of V_{DS} and I_D .
5. Repeat the above steps 2,3 for different values of V_{GS} at 0.5V to 3V.
6. All the readings are tabulated.
7. To plot the transfer characteristics, keep V_{DS} constant at 3V.
8. Vary V_{GS} and observe the values of V_{GS} and I_D .
9. Repeat steps 6 and 7 for different values of V_{DS} at 5V and 7.5 V.
10. All the readings are tabulated.
11. Plot the graphs.

Tabulations:-

Drain Characteristic:-

	$V_{GS} = 0V$		$V_{GS} = -1V$		$V_{GS} = -2V$	
Sl.No	V_{DS} (V)	I_D (mA)	V_{DS} (V)	I_D (mA)	V_{DS} (V)	I_D (mA)
1						
2						
3						

Transfer Characteristic:-

	$V_{DS} = 0.5V$		$V_{DS} = 2V$		$V_{DS} = -5V$		$V_{DS} = -10V$	
Sl.No	V_{GS} (V)	I_D (mA)	V_{GS} (V)	I_D (mA)	V_{GS} (V)	I_D (mA)	V_{GS} (V)	I_D (mA)
1								
2								
3								

Graphs:-

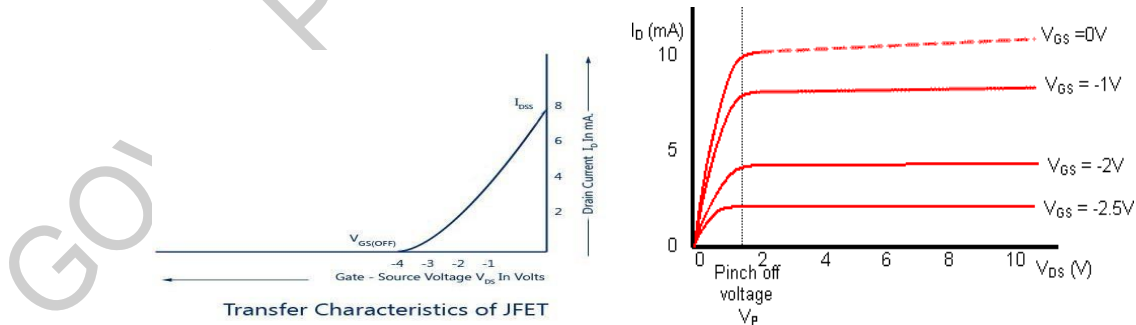

[Drain Characteristic]

Conclusion: - From the above experiment, we learnt the transfer and drain characteristic of JFET.

Experiment - 03

Aim- Construct Bridge Rectifier using different filter and to determine Ripple factor and analyze wave form with filter & without filter.

APPARATUS REQUIRED:

Sl. No	Name of the Equipment	Specification	Quantity
1	Transformer	220V/ 12V	1no
2	Diode	IN 4007	4 nos
3	Capacitor	470 μ F	2 nos
4	Inductor	250 mH	1 no
5	Resistor	1.2 K Ω	1 no
6	Connecting Probes	-	As Per Required
7	Bread Board	-	1no

Theory:-

Rectifier: - A Rectifier is an electrical device that is made of one or more than one diodes that converts the alternating current (AC) into direct current (DC). It is used for rectification where the process below shows that how it convert AC into DC.

Types of Rectifier:-

- Half Wave Rectifier
- Full Wave Rectifier

Half Wave Rectifier:- A Type of rectifier that converts only the half cycle of the alternating current (AC) into direct current (DC) is known as half wave rectifier.

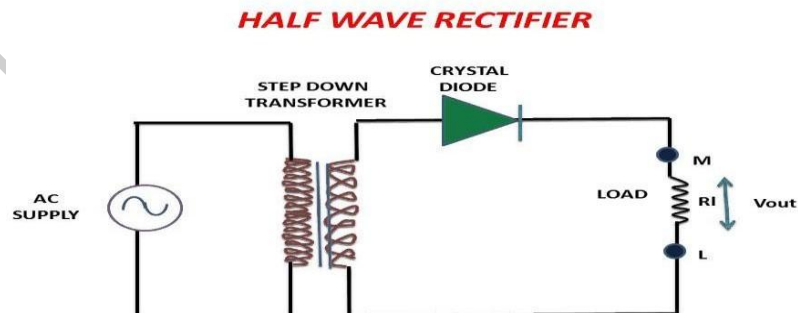

Full Wave Rectifier:- A full wave rectifier converts both positive and negative half cycles of the AC (alternating current) into DC (direct current). It provides double output voltage compared to the half-wave rectifier .

A full wave rectifier is made up of more than one diode.

There are two types of full wave rectifier.

- a) Bridge Rectifier
- b) Center-Tap Rectifier

Bridge Rectifier.- A bridge rectifier uses four diodes to convert both half cycle of the input AC into DC output.

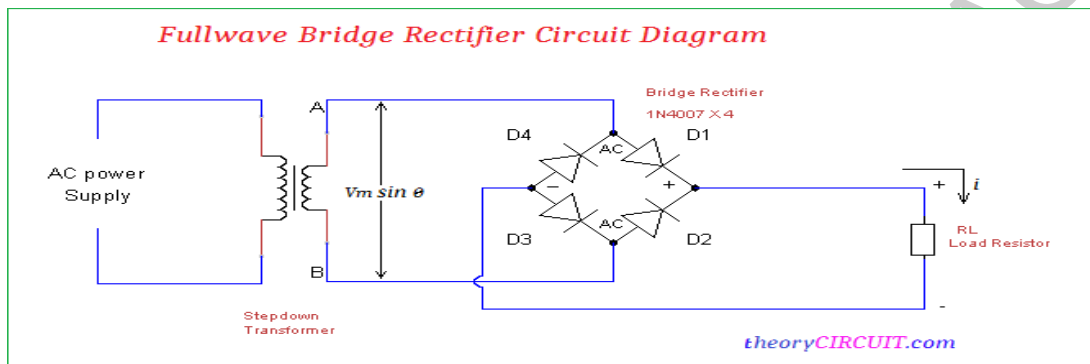

Center-Tap Rectifier: -

A center-tap transformer is a dual-voltage transformer that has two inputs (I1 & I2) and three output terminals (T1, T2, T3). The T2 terminal is connected to the center of the output coil which acts as a reference ground (0 volt reference). The T1 terminal produces positive voltage and the T3 terminal produces negative voltage with respect to the T2.

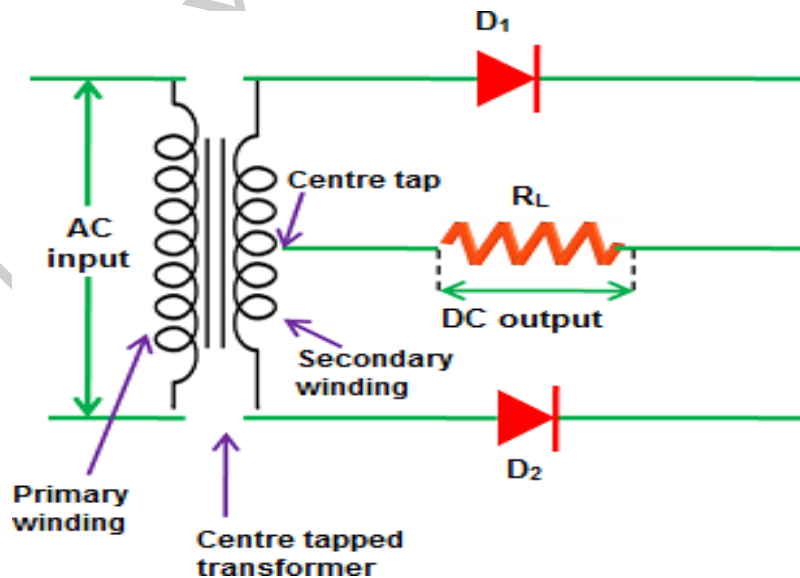

Filter Circuit:-

The filter is a device that allows passing the dc component of the load and blocks the ac component of the rectifier output. Thus the output of the filter circuit will be a steady dc voltage.

The filter circuit can be constructed by the combination of components like capacitors, resistors, and inductors. Inductor is used for its property that it allows only dc components to pass and blocks ac signals. Capacitor is used so as to block the dc and allows ac to pass.

There are three types of filter circuit.

- a) Shunt capacitor filter
- b) Choke input filter
- c) π filter

Shunt Capacitor Filter:- In this filter a capacitor is connected across the load during the rise of voltage cycle it gets charge and this charge is supply to the load during the fall in the voltage cycle. This process is repeated for each cycle and thus the ripple is reduced across the load.

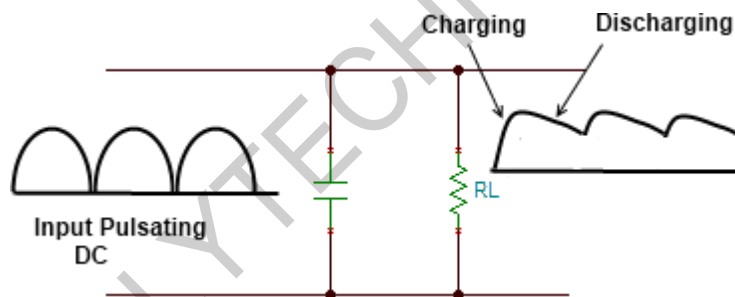

Choke input filter:-

In this circuit a choke is connected in series with the load. It offers high resistance to the AC components and allows DC component to flow through the load. The capacitor across the load is connected in parallel which filter out any AC component flowing through the choke. In this way the ripples are rectified and a smooth DC is provided through the load.

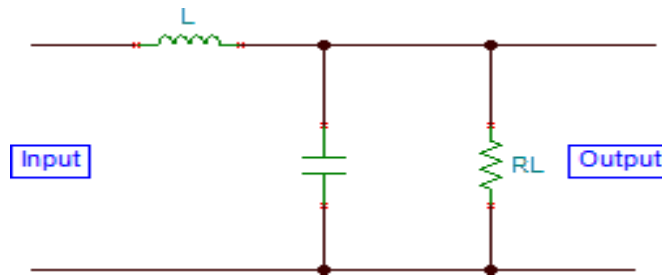

π filter:-

It consists of one inductor and two capacitor connected across its each end. The three components are arranged in shape of Greek letter Pi. It is also called capacitor input Pi filter. The input capacitor C_1 is selected to offer very low reactance to the repel frequency. Hence major parts of filtering are done by C_1 . Most of remaining repels are removed by the combining action of L and C_2 . This circuit gives much better filter then LC filter.

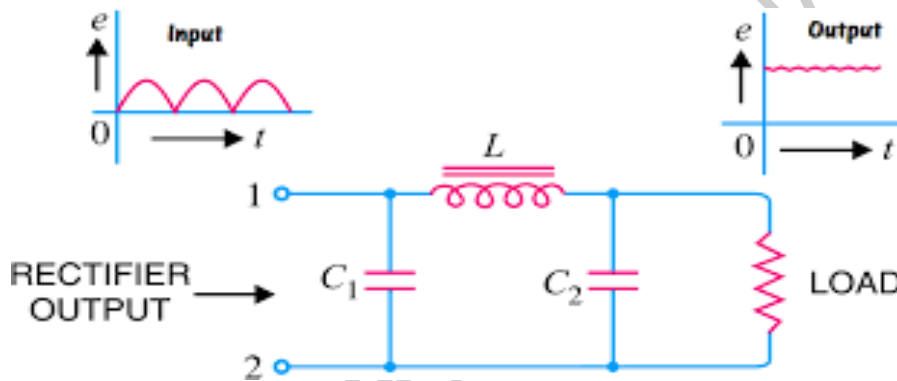

Ripple factor:- Ripple factor is a measure of effectiveness of a rectifier circuit. It is defined as the ratio of RMS value of the AC component (ripple component) I_{rms} in the output waveform to the DC component I_{dc} in the output waveform.

According to the definition of R.F, the whole load current RMS value can be given by

$$I_{RMS} = \sqrt{I_{dc}^2 + I_{ac}^2}$$

(or)

$$I_{ac} = \sqrt{I_{rms}^2 - I_{dc}^2}$$

When the above equation is divided by using I_{dc} then we can get the following equation.

$$I_{ac} / I_{dc} = 1 / I_{dc} \sqrt{I_{rms}^2 - I_{dc}^2}$$

However, here I_{ac} / I_{dc} is the ripple factor formula

$$R.F = 1 / I_{dc} \sqrt{I_{rms}^2 - I_{dc}^2} = \sqrt{(I_{rms} / I_{dc})^2 - 1}$$

Ripple Factor of Half Wave Rectifier

For half-wave rectifier,

$$I_{rms} = I_m/2$$

$$I_{dc} = I_m/\pi$$

We know the formula of $R.F = \sqrt{(I_{rms} / I_{dc})^2 - 1}$

Substitute the above I_{rms} & I_{dc} in the above equation so we can get the following.

$$R.F = \sqrt{(I_m/2 / I_m/\pi)^2 - 1} = 1.21$$

Ripple Factor of Full Wave Rectifier

For full-wave rectifier,

$$I_{rms} = I_m/\sqrt{2}$$

$$I_{dc} = 2I_m / \pi$$

We know the formula of $R.F = \sqrt{(I_{rms} / I_{dc})^2 - 1}$

Substitute the above I_{rms} & I_{dc} in the above equation so we can get the following.

$$R.F = \sqrt{(I_m/\sqrt{2} / 2I_m / \pi)^2 - 1} = 0.48$$

Procedure:-

1. We should take all the components for this experiment.
2. Make the connection as per circuit diagram.
3. Design half wave rectifier
4. Put all the filter circuit and observe the output.
5. Design Full wave rectifier.
6. Put all the filter circuit and observe the output.
7. Calculate the ripple factor.
8. Trace the wave form on tracing paper.

Wave Forms of Filters:-

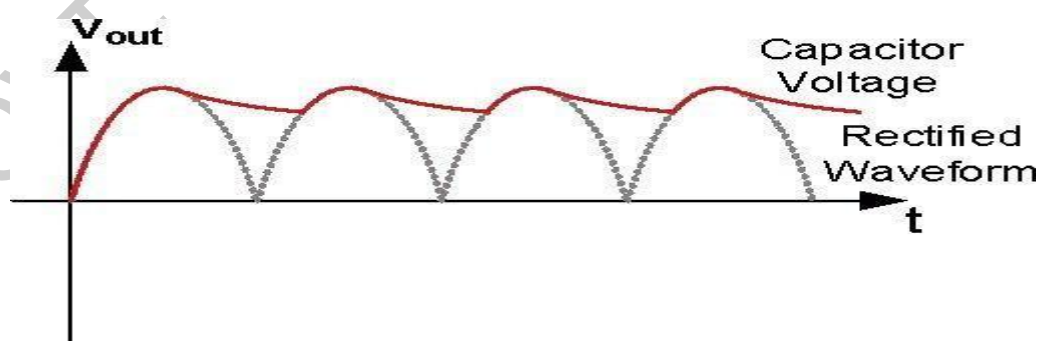

[Shunt Capacitor Filter]

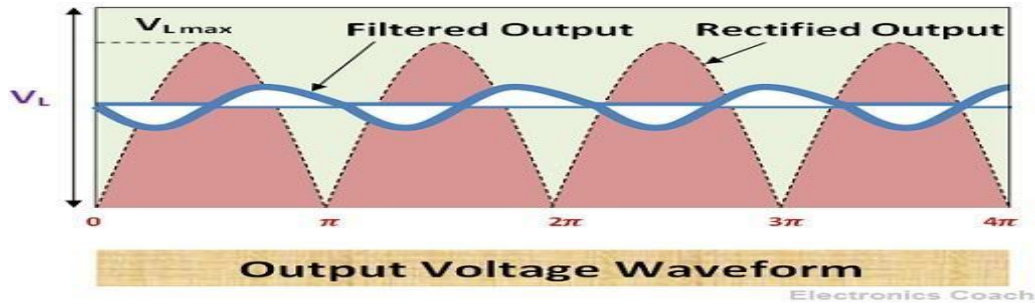

[Choke Input Filter]

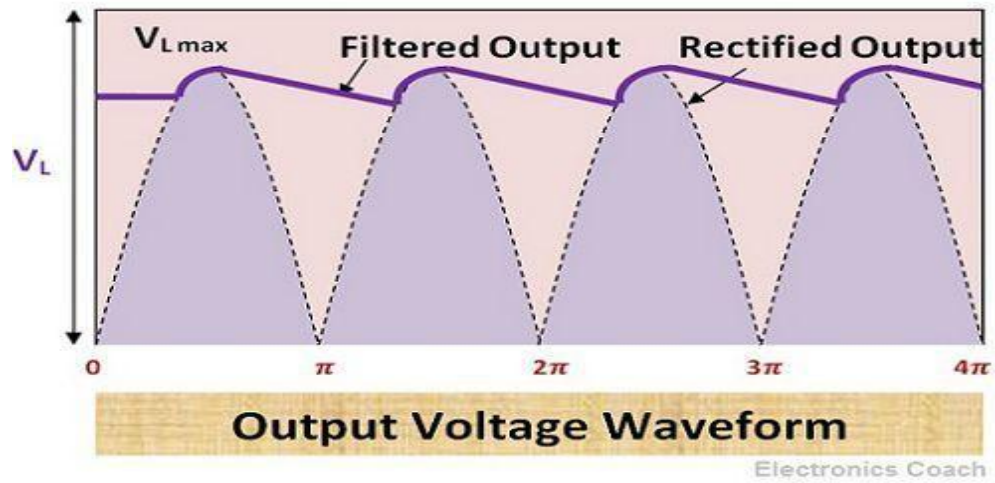

[Pi Filter]

Conclusion: - From the above experiment, we learnt about the Bridge Rectifier using different filter and determine Ripple factor and wave forms with filter and without filter.

Experiment - 04

Aim- Construct Bridge Rectifier using different filter and to determine Ripple factor.

APPARATUS REQUIRED:

Sl. No	Name of the Equipment	Specification	Quantity
1	Transformer	220V/ 12V	1no
2	Diode	IN 4007	4 nos
3	Capacitor	470 μ F	2 nos
4	Inductor	250 mH	1 no
5	Resistor	1.2 K Ω	1 no
6	Connecting Probes	-	As Per Required
7	Bread Board	-	1no

Theory:-

Rectifier: - A Rectifier is an electrical device that is made of one or more than one diodes that converts the alternating current (AC) into direct current (DC). It is used for rectification where the process below shows that how it convert AC into DC.

Types of Rectifier:-

- Half Wave Rectifier
- Full Wave Rectifier

Half Wave Rectifier:- A Type of rectifier that converts only the half cycle of the alternating current (AC) into direct current (DC) is known as half wave rectifier.

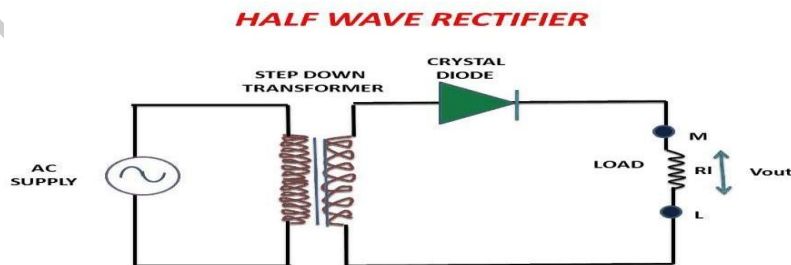

Full Wave Rectifier:- A full wave rectifier converts both positive and negative half cycles of the AC (alternating current) into DC (direct current). It provides double output voltage compared to the half-wave rectifier .

A full wave rectifier is made up of more than one diode.

There are two types of full wave rectifier.

- c) Bridge Rectifier
- d) Center-Tap Rectifier

Bridge Rectifier.- A bridge rectifier uses four diodes to convert both half cycle of the input AC into DC output.

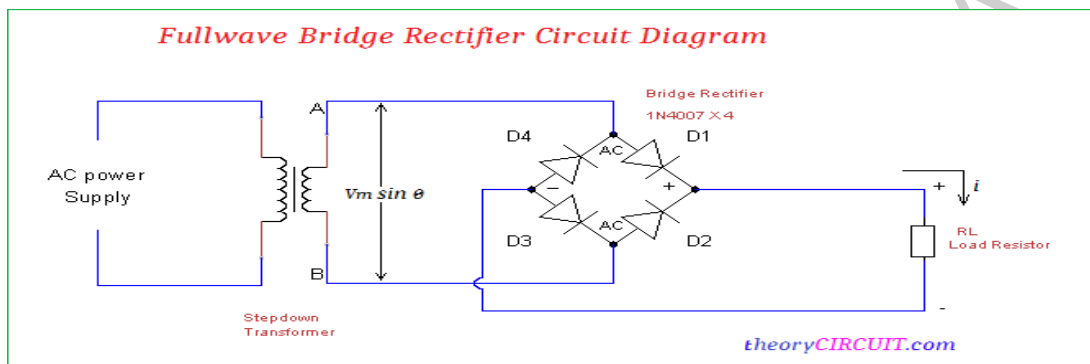

Center-Tap Rectifier: - A center-tap transformer is a dual-voltage transformer that has two inputs (I1 & I2) and three output terminals (T1, T2, T3). The T2 terminal is connected to the center of the output coil which acts as a reference ground (0 volt reference). The T1 terminal produces positive voltage and the T3 terminal produces negative voltage with respect to the T2.

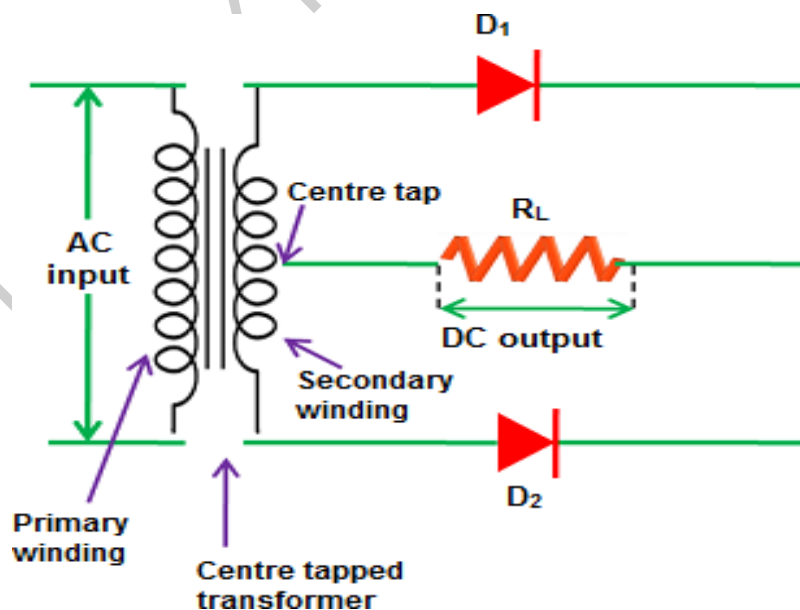

Filter Circuit:- The filter is a device that allows passing the dc component of the load and blocks the ac component of the rectifier output. Thus the output of the filter circuit will be a steady dc voltage.

The filter circuit can be constructed by the combination of components like capacitors, resistors, and inductors. Inductor is used for its property that it allows only dc components to pass and blocks ac signals. Capacitor is used so as to block the dc and allows ac to pass.

There are three types of filter circuit.

- d) Shunt capacitor filter
- e) Choke input filter
- f) π filter

Shunt Capacitor Filter:- In this filter a capacitor is connected across the load during the rise of voltage cycle it gets charge and this charge is supply to the load during the fall in the voltage cycle. This process is repeated for each cycle and thus the ripple is reduced across the load.

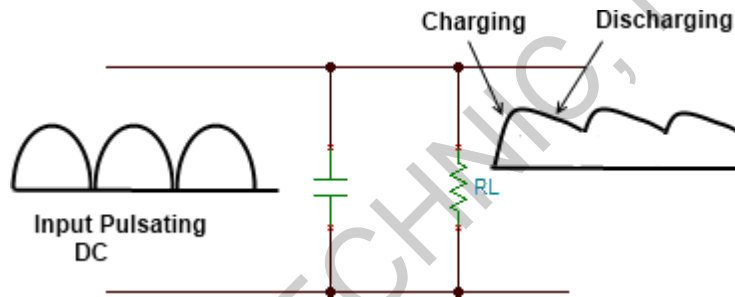

Choke input filter:- In this circuit a choke is connected in series with the load. It offers high resistance to the AC components and allows DC component to flow through the load. The capacitor across the load is connected in parallel which filter out any AC component flowing through the choke. In this way the ripples are rectified and a smooth DC is provided through the load.

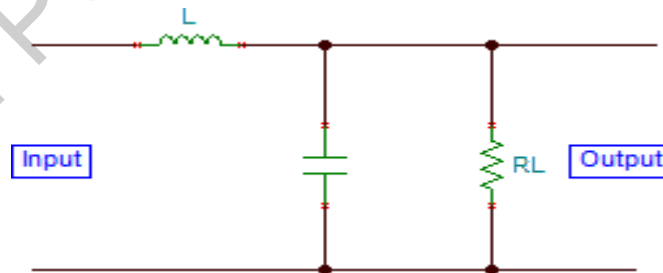

π filter:- It consists of one inductor and two capacitor connected across its each end. The three components are arranged in shape of Greek letter Pi. It is also called capacitor input Pi filter. The input capacitor C_1 is selected to offer very low reactance to the repel frequency. Hence major parts of filtering are done by C_1 . Most of remaining repels are removed by the combining action of L and C_2 . This circuit gives much better filter then LC filter.

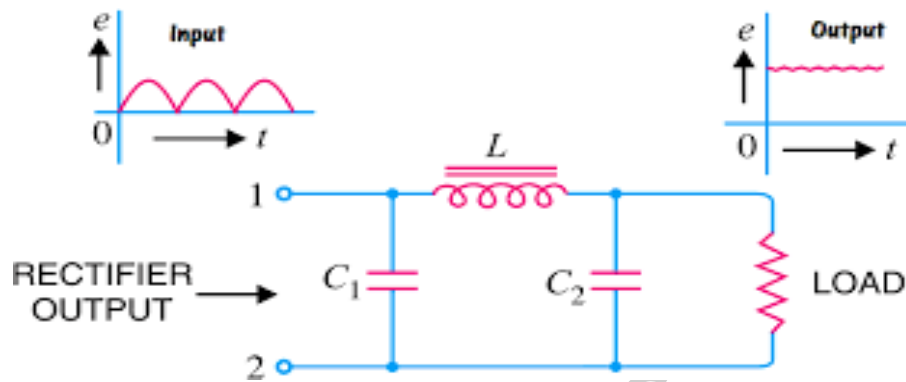

Ripple factor: Ripple factor is a measure of effectiveness of a rectifier circuit. It is defined as the ratio of RMS value of the AC component (ripple component) I_{rms} in the output waveform to the DC component I_{dc} in the output waveform.

According to the definition of R.F, the whole load current RMS value can be given by

$$I_{RMS} = \sqrt{I_{dc}^2 + I_{ac}^2}$$

(or)

$$I_{ac} = \sqrt{I_{rms}^2 - I_{dc}^2}$$

When the above equation is divided by using I_{dc} then we can get the following equation.

$$I_{ac} / I_{dc} = 1 / I_{dc} \sqrt{I_{rms}^2 - I_{dc}^2}$$

However, here I_{ac} / I_{dc} is the **ripple factor formula**

$$R.F = 1 / I_{dc} \sqrt{I_{rms}^2 - I_{dc}^2} = \sqrt{(I_{rms} / I_{dc})^2 - 1}$$

Ripple Factor of Half Wave Rectifier

For half-wave rectifier,

$$I_{rms} = I_m / 2$$

$$I_{dc} = I_m / \pi$$

We know the formula of $R.F = \sqrt{(I_{rms} / I_{dc})^2 - 1}$

Substitute the above I_{rms} & I_{dc} in the above equation so we can get the following.

$$R.F = \sqrt{(I_m/2 / I_m / \pi)^2 - 1} = 1.21$$

Ripple Factor of Full Wave Rectifier

For full-wave rectifier,

$$I_{rms} = I_m / \sqrt{2}$$

$$I_{dc} = 2I_m / \pi$$

We know the formula of $R.F = \sqrt{(I_{rms} / I_{dc})^2 - 1}$

Substitute the above I_{rms} & I_{dc} in the above equation so we can get the following.

$$R.F = \sqrt{(I_m / \sqrt{2} / 2I_m / \pi)^2 - 1} = 0.48$$

Procedure:-

- 1) We should take all the components for this experiment.
- 2) Make the connection as per circuit diagram.
- 3) Design half wave rectifier
- 4) Put all the filter circuit and observe the output.
- 5) Design Full wave rectifier.
- 6) Put all the filter circuit and observe the output.
- 7) Calculate the ripple factor.

Conclusion: - From the above experiment, we learnt about the Bridge Rectifier using different filter and determine Ripple factor.

Experiment - 05

Aim-Construct and test the regulator using Zener Diode.

APPARATUS REQUIRED:

Sl. No	Name of the Equipment	Specification	Quantity
1	Zener Diode	IN4735	1no
2	Diode	IN 4007	4 nos
3	Variable Voltage Source	0-30V	1no
4	Resistor	1 K Ω	1 no
5	Resistor	3.3 K Ω	1 no
6	Voltmeter	0-30v	2 nos
7	Ammeter	0-500 mA	2 nos
8	Connecting Probes	-	As Per Required

THEORY:- The Zener diode is operated in the breakdown or zener region, the voltage across it is substantially constant for a large current of current through it. This characteristic permits it to be used as a voltage regulator. As the lode Current increases, the Zener current decrease so that current through resistance R_s is constant. As out put voltage = $V_{in} - I_r s$, and I is constant, Therefore, output Voltage remains unchanged. The input voltage V_{in} increase, more current will flow through the zener, the voltage drop across R_s will increase but lode voltage would remain constant.

CIRCUIT DIAGRAM:

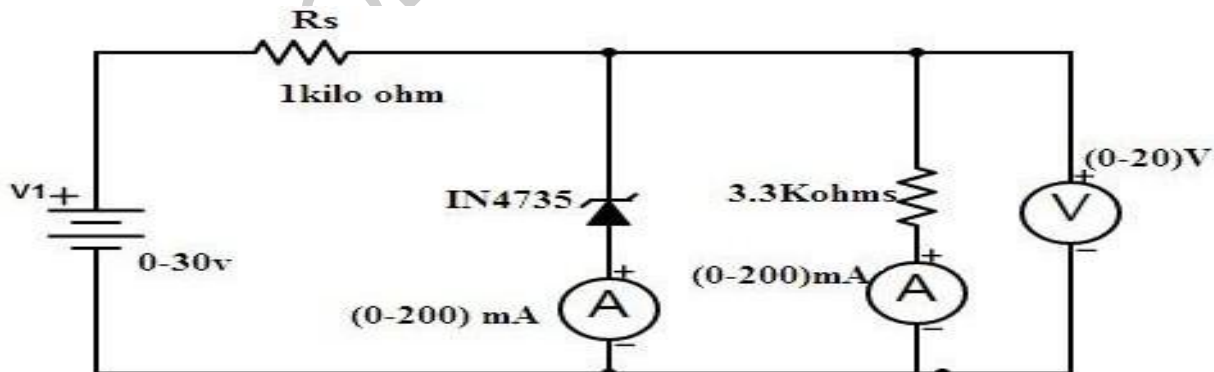

[Circuit Diagram of Zener Diode as Voltage Regulator]

PROCEDURE:

1. Connect the circuit as per the circuit diagram.
2. Keep load resistance constant (take maximum value of load resistance).
3. Vary input voltage and note down output voltage.
4. Now keep input voltage constant and vary load resistance and note down corresponding voltmeter reading.
5. Note the reading in observation table.

OBSERVATION TABLE:

Sl. No	Voltage Applied in Volts	Output Current (I_L) in mA	Output Voltage in Volt
1			
2			
2			
4			
5			

Conclusion:- From the above experiment, we learnt about the zener diode using as a voltage regulator.

Experiment - 06

Aim- Construct different types of biasing circuit and analyze the wave form
(i) Fixed bias (ii) Emitter bias (iii) Voltage divider bias

APPARATUS REQUIRED:

Sl. No	Name of the Equipment	Specification	Quantity
1	Trainer for transistor biasing	ME 624	1no
2	CRO	2 KHz	1 no
3	Connecting Probes	-	As Per Required

Theory:- Biasing is the process of providing DC voltage which helps in the functioning of the circuit. A transistor is biased in order to make the emitter base junction forward biased and collector base junction reverse biased, so that it maintains in active region, to work as an amplifier.

Transistor Biasing:-

The proper flow of zero signal collector current and the maintenance of proper collector-emitter voltage during the passage of signal is known as Transistor Biasing. The circuit which provides transistor biasing is called as Biasing Circuit.

Methods of Transistor Biasing: - The biasing in transistor circuits is done by using two DC sources V_{BB} and V_{CC} . It is economical to minimize the DC source to one supply instead of two which also makes the circuit simple.

The commonly used methods of transistor biasing are

- Base Resistor Method (Fixed Bias)
- Emitter Bias Method
- Voltage-divider Bias Method

Base Resistor Method (Fixed Bias): - The biasing circuit shown by Figure 1 has a base resistor R_B connected between the base and the V_{CC} . Here the base-emitter junction of the transistor is forward biased by the voltage drop across R_B which is the result of I_B flowing through it. From the figure, the mathematical expression for I_B is obtained as

$$I_B = \frac{V_{CC} - V_{BE}}{R_B}$$

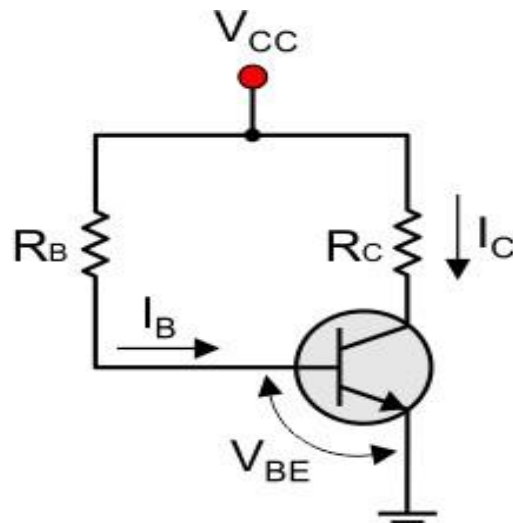

[Base Resistor Method]

Here the values of V_{CC} and V_{BE} are fixed while the value for R_B is constant once the circuit is designed. This leads to a constant value for I_B resulting in a fixed operating point due to which the circuit is named as fixed base bias. This kind of bias, results in a stability factor of $(\beta+1)$ which leads to very poor thermal stability. The reason behind this is the fact the β - parameter of a transistor is unpredictable and varies up to a large extent even in the case of transistor with the same model and type. This variation in β results in large changes in I_C which cannot be compensated by any means in the proposed design. Hence it can be concluded that this kind of β dependent bias is prone to the changes in operating point brought about by the variations in transistor characteristics and temperature.

However it is to be noted that fixed base bias is most simple and uses less number of components. Moreover it offers the chance for the user to change the operating point anywhere in the active region just by changing the value of R_B in the design. Further it offers no load on the source as there is no resistor across base-emitter junction. Due to these factors this kind of biasing is used in switching applications and to achieve automatic gain control in the transistors. Here, the expressions for other voltages and currents are given as

$$V_B = V_{BE} = V_{CC} - I_B R_B$$

$$V_C = V_{CC} - I_C R_C = V_{CC} - V_{CE}$$

$$I_C = \beta I_B$$

$$I_E \approx I_C$$

Emitter Bias Circuit: -

This biasing network (Figure 5) uses two supply voltages, V_{CC} and V_{EE} , which are equal but opposite in polarity. Here V_{EE} forward biases the base-emitter junction through R_E while V_{CC} reverse biases the collector-base junction. Moreover

$$V_E = -V_{EE} + I_E R_E$$

$$V_C = V_{CC} - I_C R_C$$

$$V_B = V_{BE} + V_E$$

$$I_C = \beta I_B$$

$$I_E \approx I_C$$

In this kind of biasing, I_C can be made independent of both β and V_{BE} by choosing $R_E \gg R_B/\beta$ and $V_{EE} \gg V_{BE}$, respectively; which results in a stable operating point.

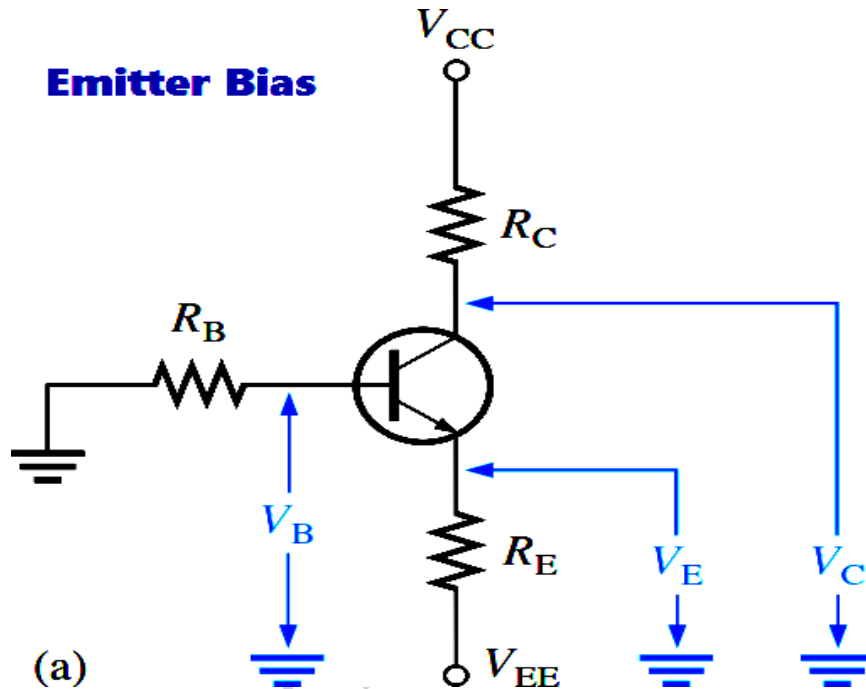

Voltage-divider Bias Method: - This type of biasing network (Figure 7) employs a voltage divider formed by the resistors R_1 and R_2 to bias the transistor. This means that here the voltage developed across R_2 will be the base voltage of the transistor which forward biases its base-emitter junction. In general, the current through R_2 will be fixed to be 10 times required base current, I_B (i.e. $I_2 = 10I_B$). This is done to avoid its effect on the voltage divider current or on the changes in β . Further, from the circuit, one gets

$$I_B = V_{CC} \frac{R_2}{R_1 + R_2}$$

$$V_E = I_E R_E$$

$$V_B = I_2 R_2 = V_{BE} + V_E$$

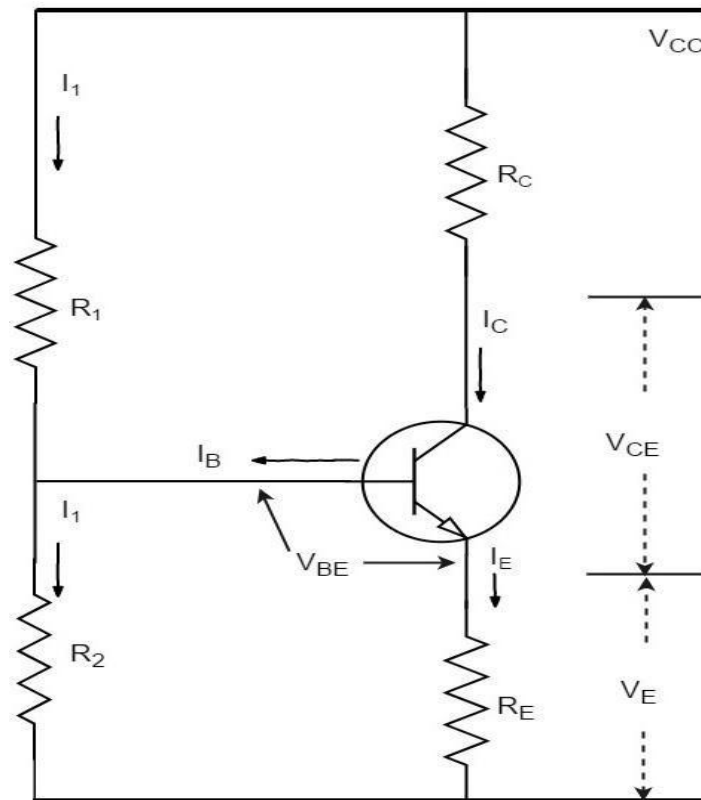

[Voltage-divider Bias Method]

In this kind of biasing, I_C is resistant to the changes in both β as well as V_{BE} which results in a stability factor of 1 (theoretically), the maximum possible thermal stability. This is because, as I_C increases due to a rise in temperature, I_E also increases causing an increase in the emitter voltage V_E which in turn reduces the base-emitter voltage, V_{BE} . This results in the decrease of base current I_B which restores I_C to its original value. The higher stability offered by this biasing circuit makes it to be most widely used inspite of providing a decreased amplifier gain due to the presence of R_E .

Procedure:-

1. We should take all the components for this experiment.
2. Make the connection as per circuit diagram.
3. Switch ON the kit using ON/OFF toggle switch
4. Note down the value of currents and voltages.
5. Compare these observed values with calculated value.

Conclusion: - From this experiment, we learnt the biasing methods of transistor

Experiment - 07

Aim- Study the single stage CE amplifier and find Gain.

APPARATUS REQUIRED:

Sl. No	Name of the Equipment	Specification	Quantity
1	Single Stage Amplifier Trainer	-	1no
2	Connecting Probes	-	As Per Required

Theory:-

Single stage CE amplifier: -

Fig shows a single stage CE amplifier. The different circuit elements and their functions are described as follows.

(i) Biasing circuit: The resistances R_1 , R_2 and R_E form the biasing and stabilization circuit.

(ii) Input capacitance C_{in} : This is used to couple the signal to the base of the transistor. If this is not used, the signal source resistance will come across R_2 and thus change the bias. The capacitor C_{in} allows only a.c. signal to flow.

(iii) Emitter bypass capacitor C_E : This is connected in parallel with R_E to provide a low reactance path to the amplified a.c. signal. If it is not used, then amplified a.c. signal flowing through R_E will cause a voltage drop across it, thereby shifting the output voltage.

(iv) Coupling capacitor C : This is used to couple the amplified signal to the output device. This capacitor C allows only a.c. signal to flow.

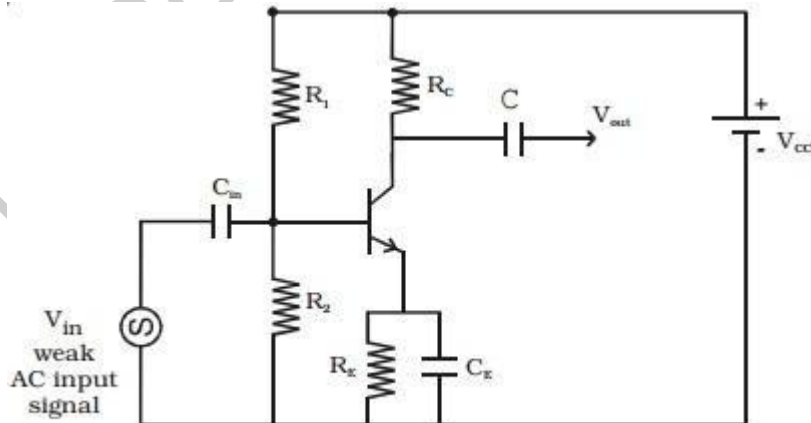

Fig Single stage CE amplifier

Working: -

When a weak input a.c. signal is applied to the base of the transistor, a small base current flows. Due to transistor action, a much larger a.c. current flows through collector load R_C , a large voltage appears across R_C and hence at the output. Therefore, a weak signal applied to the base appears in amplified form in the collector circuit. Voltage gain (A_v) of the amplifier is the ratio of the amplified output voltage to the input voltage.

Frequency response and bandwidth:-

The voltage gain (A_v) of the amplifier for different input frequencies can be determined. A graph can be drawn by taking frequency (f) along X-axis and voltage gain (A_v) along Y-axis. The frequency response curve obtained will be of the form as shown in Fig. It can be seen that the gain decreases at very low and very high frequencies, but it remains constant over a wide range of mid-frequency region.

Lower cut off frequency (f_L) is defined as the frequency in the low

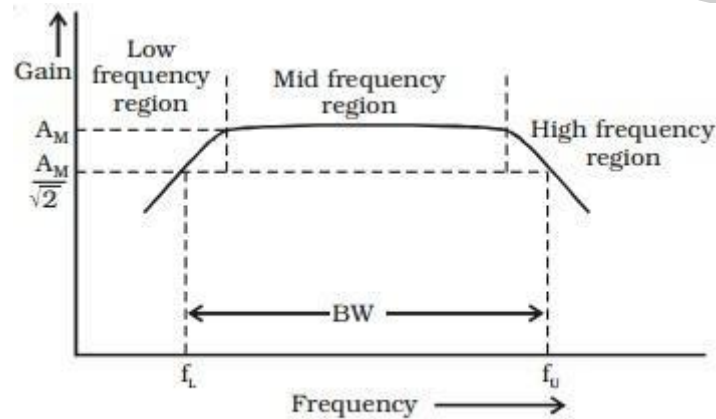

Fig Frequency response curve

frequency range at which the gain of the amplifier is $1/\sqrt{2}$ times the mid frequency gain (A_M). Upper cut off frequency (f_U) is defined as the frequency in the high frequency range at which the gain of the amplifier is $1/\sqrt{2}$ times the mid frequency gain (A_M).

Bandwidth is defined as the frequency interval between lower cut off and upper cut off frequencies.

$$BW = f_U - f_L$$

Common Emitter Voltage Gain:-

The Voltage Gain of the common emitter amplifier is equal to the ratio of the change in the input voltage to the change in the amplifiers output voltage. Then ΔV_L is V_{out} and ΔV_B is V_{in} . But voltage gain is also equal to the ratio of the signal resistance in the Collector to the signal resistance in the Emitter and is given as:

$$\text{Voltage Gain} = \frac{V_{out}}{V_{in}} = \frac{\Delta V_L}{\Delta V_B} = -\frac{R_L}{R_E}$$

Procedure:-

1. We should take all the components for this experiment.
2. Make the connection as per circuit diagram.
3. Switch ON the kit using ON/OFF toggle switch
4. Note down the value of currents and voltages.
5. Compare these observed values with calculated value

Conclusion:- From this experiment, we learnt about the single stage CE amplifier and its Gain.

GOVT. POLYTECHNIC, NAYAGARH

Experiment - 08

Aim- Study multi stage R-C Coupled amplifier to determine frequency response and Gain.

APPARATUS REQUIRED:

Sl. No	Name of the Equipment	Specification	Quantity
1	R-C Coupled Amplifier Trainer	-	1no
2	CRO	2 KHz	1 no
3	Connecting Probes	-	As Per Required

Theory:-

A Resistance Capacitance (RC) Coupled Amplifier is basically a multi-stage amplifier circuit extensively used in electronic circuits. Here the individual stages of the amplifier are connected together using a resistor–capacitor combination due to which it bears its name as RC Coupled.

A two-stage amplifier whose individual stages are nothing but the common emitter amplifiers. Hence the design of individual stages of the RC coupled amplifiers is similar to that in the case of common emitter amplifiers in which the resistors R_1 and R_2 form the biasing network while the emitter resistor R_E form the stabilization network. Here the C_E is also called bypass capacitor which passes only AC while restricting DC, which causes only DC voltage to drop across R_E while the entire AC voltage will be coupled to the next stage.

Further, the coupling capacitor C_C also increases the stability of the network as it blocks the DC while offers a low resistance path to the AC signals, thereby preventing the DC bias conditions of one stage affecting the other. In addition, in this circuit, the voltage drop across the collector- emitter terminal is chosen to be 50% of the supply voltage V_{CC} in order to ensure appropriate biasing point.

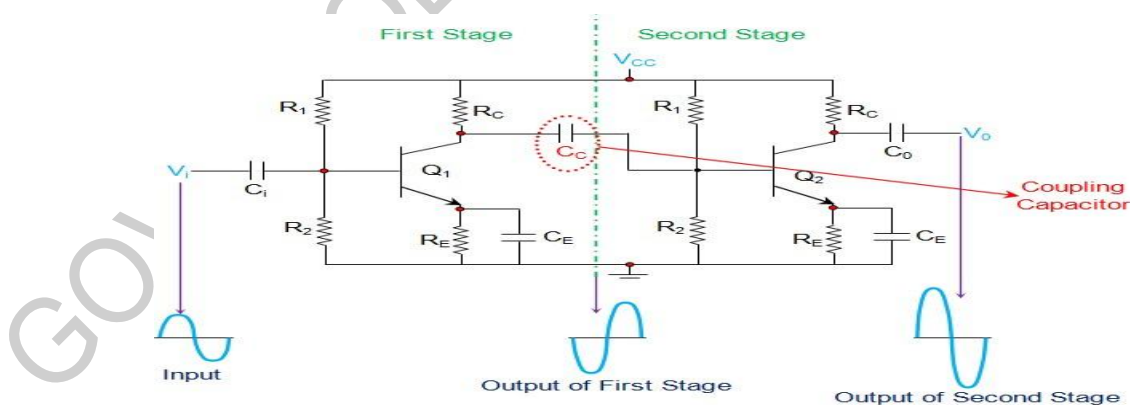

Figure 1 Two-Stage RC Coupled Amplifier

In this kind of amplifier, the input signal applied at the base of the transistor in stage 1 (Q_1) is amplified and appears at its collector terminal with a phase-shift of 180° .

The AC component of this signal is coupled to the second stage of the RC coupled amplifier through the coupling capacitor C_C and thus appears as an input at the base of the second transistor Q_2 . This is further amplified and is passed-on as an output of the second stage and is available at the collector terminal of Q_2 after being shift by 180° in its phase. This means that the output of the second stage will be 360° out-of-phase with respect to the input, which in turn indicates that the phase of the input signal and the phase of the output signal obtained at stage II will be identical.

Further it is to be noted that the cascading of individual amplifier stages increases the gain of the overall circuit as the net gain will be the product of the gain offered by the individual stages. However in real scenario, the net gain will be slightly less than this, due to the loading effect. In addition, it is important to note that by following the pattern exhibited by Figure 1, one can cascade any number of common emitter amplifiers but by keeping in mind that when the number of stages are even, the output will be in-phase with the input while if the number of stages are odd, then the output and the input will be out-of-phase.

Frequency Response of RC Coupled Amplifier:-

The frequency response of a RC coupled amplifier (a curve of amplifier's gain v/s frequency), shown by Figure 2, indicates that the gain of the amplifier is constant over a wide range of mid-frequencies while it decreases considerably both at low and high frequencies. This is because, at low frequencies, the reactance of coupling capacitor C_C is high which causes a small part of the signal to couple from one stage to the other. Moreover for the same case, even the reactance of the emitter capacitor C_E will be high due to which it fails to shunt the emitter resistor R_E effectively which in turn reduces the voltage gain.

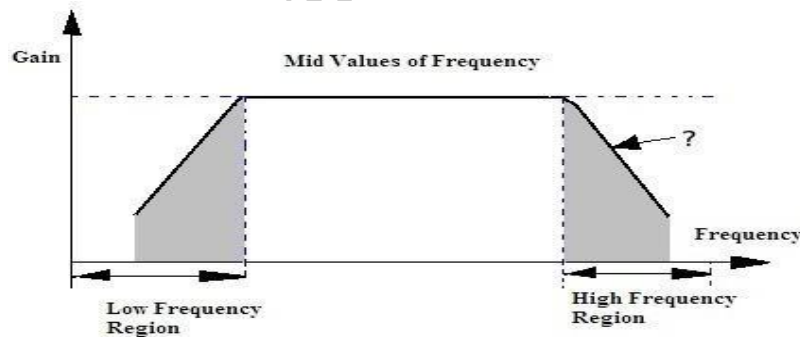

[Frequency Response of R-C Coupled Amplifier]

On the other hand, at high frequencies, the reactance of C_C will be low which causes it to behave like a short circuit. This results in an increase in the loading effect of the next stage and thus reduces the voltage gain. In addition to this, for this case, the capacitive reactance of the base-emitter junction will be low. This results in a reduced voltage gain as it causes the base current

to increase which in turn decreases the current amplification factor β . However, in mid-frequency range, as the frequency increases, the reactance of C_C goes on decreasing which would lead to the increase in gain if not compensated by the fact that the reduction in reactance leads to an increase in the loading effect. Due to this reason, the gain of the amplifier remains uniform/constant throughout the mid-frequency band.

Procedure:-

1. We should take all the components for this experiment.
2. Make the connection as per circuit diagram.
3. Switch ON the kit using ON/OFF toggle switch
4. The input signal is applied with the function generator.
5. The values of the voltage are observed and noted at the first stage and the second stage.
6. Based on the values noted the gains at the individual stages are calculated.
7. This is continued for multiple frequencies.
8. Finally, the graph is plotted in between the gain values and the multiple frequencies applied to the circuit.

Observation Table:-

Sl. No	Frequency (Hz)	Input Voltage V_{in} (volts)	Output Voltage V_o (volts)	Gain (DB)
1				
2				
3				
4				
5				

Conclusion: - From the above experiment, we learnt about the multi stage R-C coupled amplifier & its frequency response and gain.

Experiment - 09

Aim- Construct & Find the gain

- (i) Class A Amplifier (ii) Class B. Amplifier (iii) Class C Tuned amplifier

APPARATUS REQUIRED:

SI. No	Name of the Equipment	Specification	Quantity
1	Amplifier Trainer Kit	-	1no
2	CRO	2 KHZ	1 no
3	Connecting Probes	-	As Per Required

Theory:-

Amplifier: - An amplifier is an electronic device that increases the voltage, current, or power of a signal. Amplifiers are used in wireless communications and broadcasting, and in audio equipment of all kinds. They can be categorized as either weak-signal amplifiers or power amplifiers.

Class A Amplifier: -

Class A Amplifiers are the most common type of amplifier topology as they use just one output switching transistor (Bipolar, FET, IGBT, etc) within their amplifier design. This single output transistor is biased around the Q-point within the middle of its load line and so is never driven into its cut-off or saturation regions thus allowing it to conduct current over the full 360 degrees of the input cycle. Then the output transistor of a class-A topology never turns "OFF" which is one of its main disadvantages.

Class "A" amplifiers are considered the best class of amplifier design due mainly to their excellent linearity, high gain and low signal distortion levels when designed correctly. Although seldom used in high power amplifier applications due to thermal power supply considerations, class-A amplifiers are probably the best sounding of all the amplifier classes mentioned here and as such are used in high-fidelity audio amplifier designs.

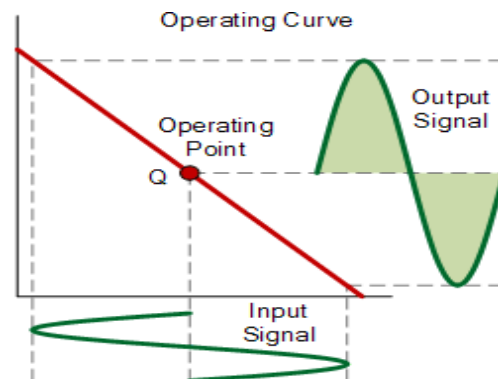
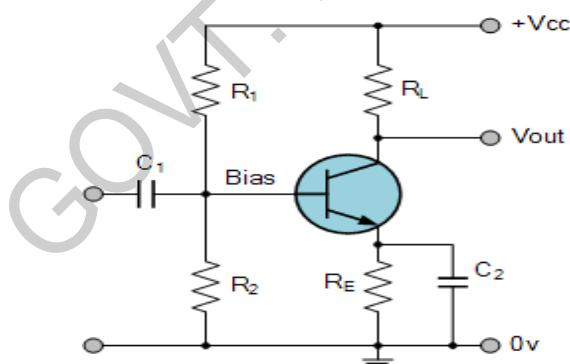

[Class A Amplifier]

To achieve high linearity and gain, the output stage of a class A amplifier is biased "ON" (conducting) all the time. Then for an amplifier to be classified as "Class A" the zero signal idle current in the output stage must be equal to or greater than the maximum load current (usually a loudspeaker) required to produce the largest output signal.

As a class A amplifier operates in the linear portion of its characteristic curves, the single output device conducts through a full 360 degrees of the output waveform. Then the class A amplifier is equivalent to a current source.

Since a class A amplifier operates in the linear region, the transistors base (or gate) DC biasing voltage should be chosen properly to ensure correct operation and low distortion. However, as the output device is "ON" at all times, it is constantly carrying current, which represents a continuous loss of power in the amplifier.

Due to this continuous loss of power class A amplifiers create tremendous amounts of heat adding to their very low efficiency at around 30%, making them impractical for high-power amplifications. Also due to the high idling current of the amplifier, the power supply must be sized accordingly and be well filtered to avoid any amplifier hum and noise. Therefore, due to the low efficiency and overheating problems of Class A amplifiers, more efficient amplifier classes have been developed.

Calculations in a Class A Amplifier

The biasing base current is given by the formula

$$I(B) = (DC \text{ Input Voltage} - V_{(BE)})/R(b)$$

$$I(C) = I(B) \times DC \text{ current gain}$$

$$V_{(CE)} = DC \text{ Input Voltage} - (I(C) \times R(c))$$

$$\text{Voltage gain} = V_{(out)}/V_{(in)}$$

Class B Amplifier: -

Class B amplifiers were invented as a solution to the efficiency and heating problems associated with the previous class A amplifier. The basic class B amplifier uses two complementary transistors either bipolar or FET for each half of the waveform with its output stage configured in a "push-pull" type arrangement, so that each transistor device amplifies only half of the output waveform.

In the class B amplifier, there is no DC base bias current as its quiescent current is zero, so that the dc power is small and therefore its efficiency is much higher than that of the class A amplifier. However, the price paid for the improvement in the efficiency is in the linearity of the switching device.

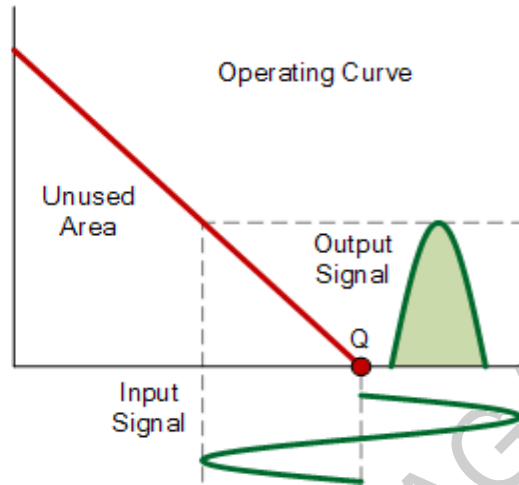
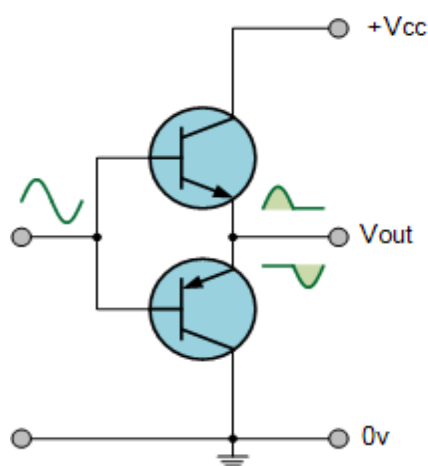

[Class B Amplifier]

When the input signal goes positive, the positive biased transistor conducts while the negative transistor is switched "OFF". Likewise, when the input signal goes negative, the positive transistor switches "OFF" while the negative biased transistor turns "ON" and conducts the negative portion of the signal. Thus the transistor conducts only half of the time, either on positive or negative half cycle of the input signal.

Then we can see that each transistor device of the class B amplifier only conducts through one half or 180 degrees of the output waveform in strict time alternation, but as the output stage has devices for both halves of the signal waveform the two halves are combined together to produce the full linear output waveform.

This push-pull design of amplifier is obviously more efficient than Class A, at about 50%, but the problem with the class B amplifier design is that it can create distortion at the zero-crossing point of the waveform due to the transistors dead band of input base voltages from -0.7V to +0.7.

We remember from the **Transistor** tutorial that it takes a base-emitter voltage of about 0.7 volts to get a bipolar transistor to start conducting. Then in a class B amplifier, the output transistor is not "biased" to an "ON" state of operation until this voltage is exceeded.

This means that the the part of the waveform which falls within this 0.7 volt window will not be reproduced accurately making the class B amplifier unsuitable for precision audio amplifier applications.

To overcome this zero-crossing distortion (also known as Crossover Distortion) class AB amplifiers were developed.

Class C Amplifier: -

The Class C Amplifier design has the greatest efficiency but the poorest linearity of the classes of amplifiers mentioned here. The previous classes, A, B and AB are considered linear amplifiers, as the output signals amplitude and phase are linearly related to the input signals amplitude and phase.

However, the class C amplifier is heavily biased so that the output current is zero for more than one half of an input sinusoidal signal cycle with the transistor idling at its cut-off point. In other words, the conduction angle for the transistor is significantly less than 180 degrees, and is generally around the 90 degrees area.

While this form of transistor biasing gives a much improved efficiency of around 80% to the amplifier, it introduces a very heavy distortion of the output signal. Therefore, class C amplifiers are not suitable for use as audio amplifiers.

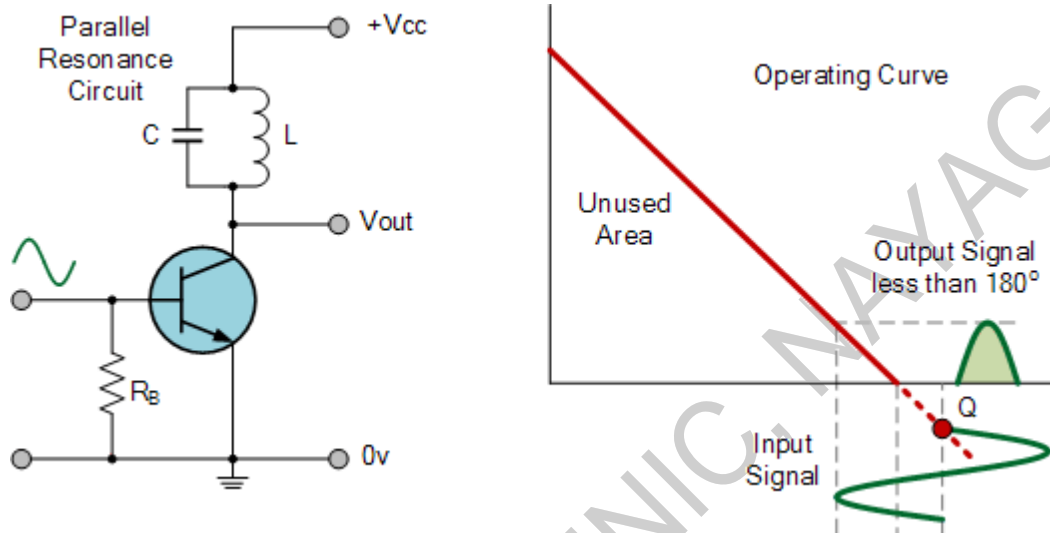

[Class C Amplifier]

Due to its heavy audio distortion, class C amplifiers are commonly used in high frequency sine wave oscillators and certain types of radio frequency amplifiers, where the pulses of current produced at the amplifiers output can be converted to complete sine waves of a particular frequency by the use of LC resonant circuits in its collector circuit.

Procedure:-

1. We should take all the components for this experiment.
2. Make the connection as per circuit diagram.
3. Switch ON the kit using ON/OFF toggle switch
4. The input signal is applied with the function generator.
5. The values of the voltage are observed and noted.
6. Calculate Gain.

Conclusion: - From the above experiment, we learnt about the class of amplifier.

Experiment - 10

Aim- Construct & test push-pull amplifier & observe the wave form.

APPARATUS REQUIRED:

Sl. No	Name of the Equipment	Specification	Quantity
1	Push Pull Amplifier Trainer Kit	-	1no
2	CRO	2 KHz	1 no
3	Function Generator	2 KHz	1 no
2	Connecting Probes	-	As Per Required

Theory:-

Push-Pull Amplifier: - It is a power amplifier which is used to supply high power to the load. It consists of two transistors in which one is NPN and another is PNP. One transistor pushes the output on positive half cycle and other pulls on negative half cycle, this is why it is known as Push-Pull Amplifier. The advantage of Push-Pull amplifier is that there is no power dissipated in output transistor when signal is not present. There are three classification of Push-Pull Amplifier but generally Class B Amplifier is considered as Push Pull Amplifier.

- Class A amplifier
- Class B amplifier

Class A Amplifier: -

Class A configuration is the most common power amplifier configuration. It consists of only one switching transistor which is set to remain ON always. It produces minimum distortion and maximum amplitude of output signal. The efficiency of Class A amplifier is very low near to 30%. The stages of the Class A amplifier allows same amount of load current to flow through it even when there is not input signal connected; therefore large heat sinks are needed for the output transistors.

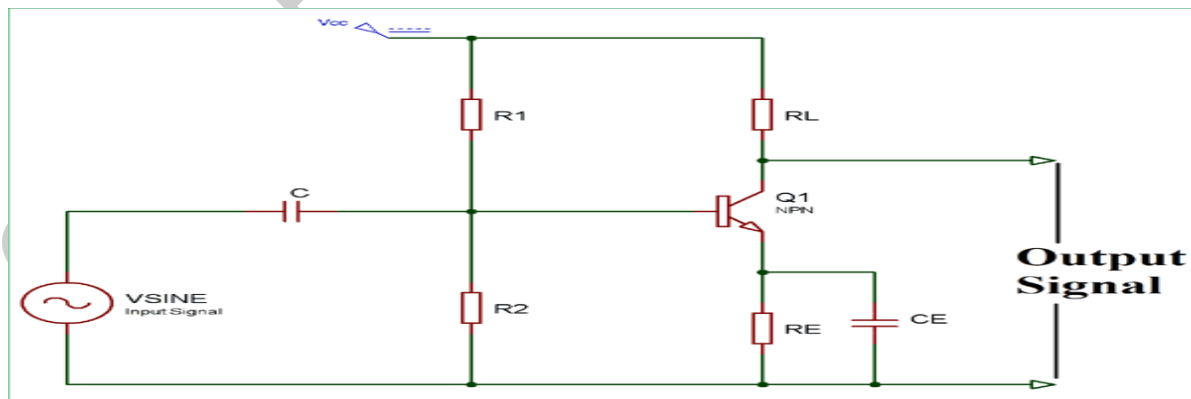

Class B Amplifier: -

Class B amplifier is the actual Push-Pull Amplifier. Efficiency of Class B amplifier is higher than Class A amplifier, as it consists of two transistors NPN and PNP. The Class B amplifier circuit is biased in such a way that each transistor will work on one half cycle of the input waveform. Therefore, the conduction angle of this type of amplifier circuit is 180 Degree. One transistor pushes the output on positive half cycle and other pulls on negative half cycle, this is why it is known as Push-Pull Amplifier.

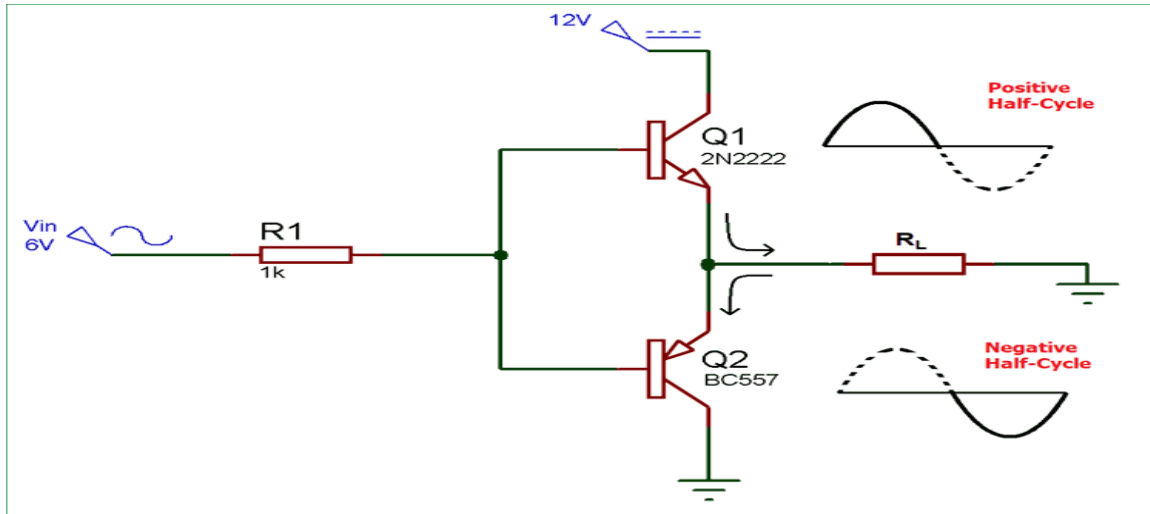

Class B generally suffers from an effect known as Crossover Distortion in which signal get distorted at 0V. We know that, a transistor requires 0.7v at its base-emitter junction to turn it on. So when AC input voltage is applied to push-pull amplifier, it starts increasing from 0 and until it reaches to 0.7v, transistor remains in OFF state and we don't get any output. Same thing happen with PNP transistor in negative half cycle of AC wave, this is called Dead Zone. To overcome this problem, diodes are used for biasing, and then the amplifier is known as Class AB Amplifier.

Procedure:-

1. We should take all the components for this experiment.
2. Make the connection as per circuit diagram.
3. Switch ON the kit using ON/OFF toggle switch
4. The input signal is applied with the function generator.
5. Connect the output to the CRO.
6. Now vary the amplitude and frequency of the signal by their respective points.
7. See the output on CRO and verify the difference between input and output.
8. Then observe the wave form.
9. Trace the wave form.

Conclusion: - From the above experiment, we learnt about the push-pull amplifier.

Experiment - 11

Aim- Construct & calculate the frequency of

- (i) Hartly Oscillator (ii) Collpitts Oscillator (iii) Wein Bridge Oscillator (iv) R-C Phase Shift Oscillator and draw wave form & calculate the frequency.

APPARATUS REQUIRED:

SI. No	Name of the Equipment	Specification	Quantity
1	Oscillator Trainer Kit	-	1no
2	Connecting Probes	-	As Per Required

Theory:-

Oscillators:-

The oscillator works on the principle of the oscillation and it is a mechanical or electronic device. The periodic variation between the two things is based on the changes in the energy. The oscillations are used in the watches, radios, metal detectors and in many other devices use the oscillators.

Principle of Oscillators: -

The oscillator converts the direct current from the power supply to an alternating current and they are used in many of the electronic devices. The signals used in the oscillators are a sine wave and the square wave. The some of the examples are the signals are broadcasted by the radio and television transmitter, clocks which are used in the computers and in the video games.

Hartley oscillator:-

The Hartley oscillator is an electronic oscillator. The frequency of this oscillation is determined by the tuned circuit. The tuned circuit consists of the capacitor and inductor; hence it is an LC oscillator. In 1915 by American engineer Ralph Hartley has invented this oscillator. The features of the Hartley circuit are the tuned circuit consists of a single capacitor in parallel with the two inductors which are in series. From the center connection of the two inductors for oscillation purpose, the feedback signal is taken.

The Hartley oscillator is parallel to the Colpitts apart from that it uses a pair of tapping coils as an alternate of two tapped capacitors. From the below circuit the output voltage is developed across the inductor L1 and the feedback voltages are across the inductor L2. The feedback network is given in the mathematical expression which is given below

$$\text{Feedback network} = \frac{X_{L2}}{X_{L1}} = \frac{L_2}{L_1}$$

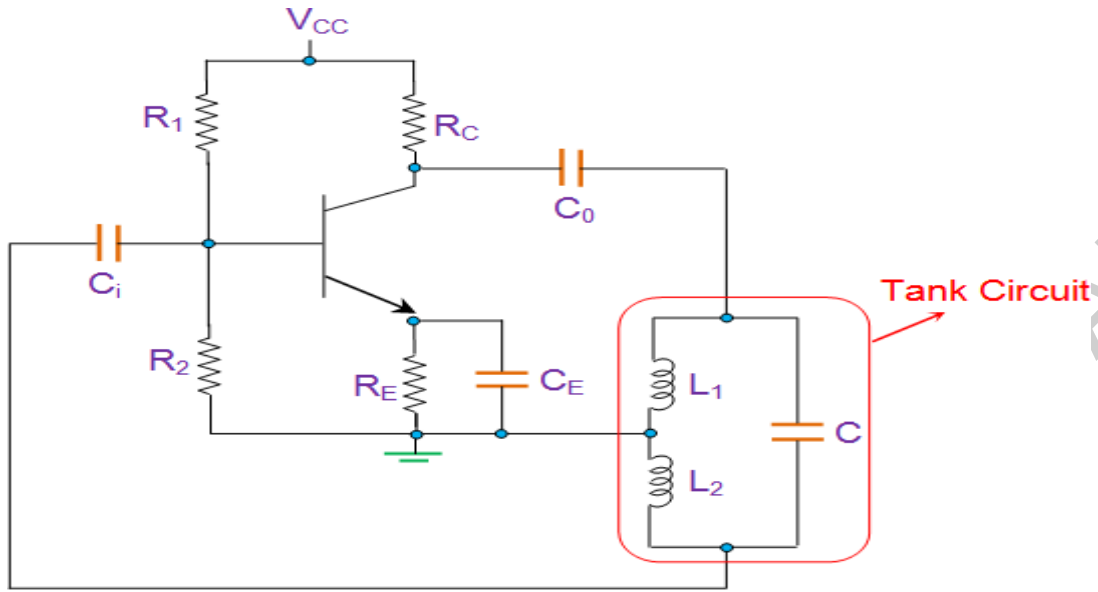

Figure 1 Hartley Oscillator

Colpitts Oscillator: -

The Colpitts Oscillator was by American engineering by Edwin H. Colpitts in the year of 1918. This oscillator is a combination of both inductors and capacitor. The features of the Colpitts Oscillator are the feedback for the active devices and they are taken from the voltage divider and made up of two capacitors which are in series across the inductor.

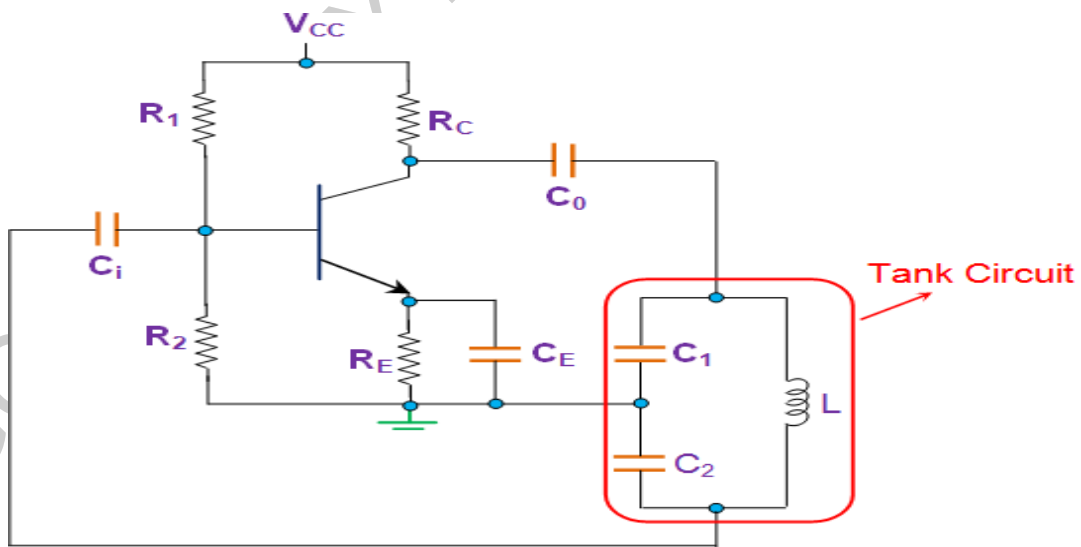

Figure 1 Colpitts Oscillator

The Colpitts circuits consist of gain devices such as the bipolar junction, field effect transistor, operational amplifier and vacuum tubes. The output is connected to an input in a feedback loop it has a parallel tuned circuit and it functioned as a band-pass filter is used as a frequency of the oscillator. This oscillator is an electrically dual of the Hartley oscillator hence the feedback signal is taken from the inductive voltage divider it has two coils in the series.

The following circuit diagram shows the common base Colpitts circuit. The inductor L and the both the capacitors C_1 & C_2 are in series with the parallel resonant tank circuit and it gives the frequency of the oscillator. The voltage across the C_2 terminal is applied to the base-emitter junction of the transistor to create the feedback oscillations.

Wien Bridge Oscillator:-

A Wien-Bridge Oscillator is a type of phase-shift oscillator which is based upon a Wien-Bridge network (Figure 1a) comprising of four arms connected in a bridge fashion. Here two arms are purely resistive while the other two arms are a combination of resistors and capacitors. In particular, one arm has resistor and capacitor connected in series (R_1 and C_1) while the other has them in parallel (R_2 and C_2). This indicates that these two arms of the network behave identical to that of high pass filter or low pass filter.

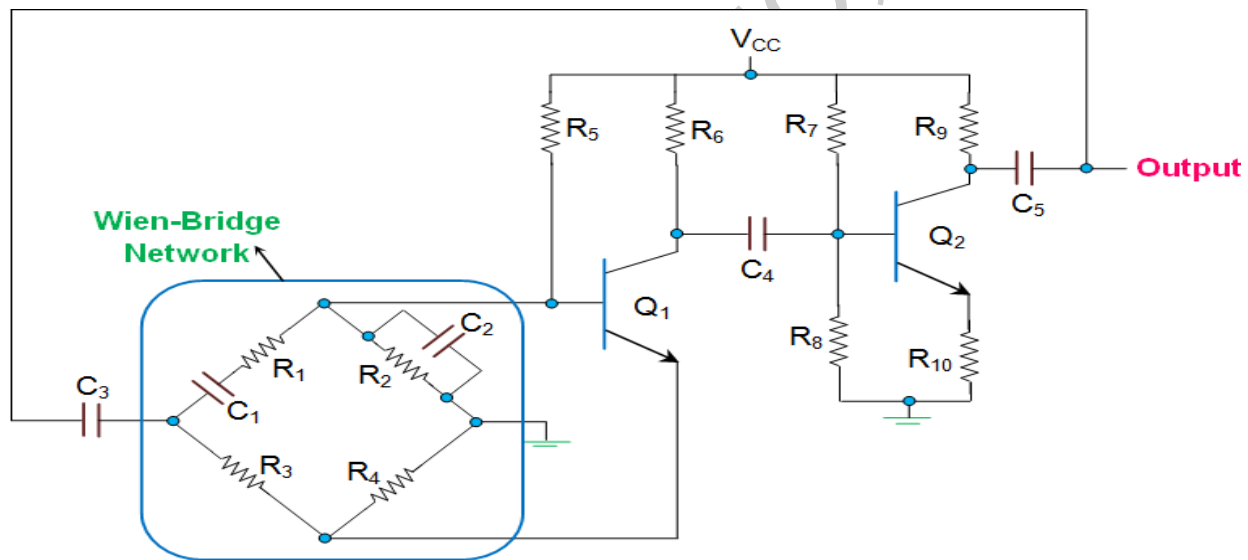

Figure 2 Wien-Bridge Oscillator Using BJT

In this circuit, at high frequencies, the reactance of the capacitors C_1 and C_2 will be much less due to which the voltage V_0 will become zero as R_2 will be shorted. Next, at low frequencies, the reactance of the capacitors C_1 and C_2 will become very high.

However even in this case, the output voltage V_0 will remain at zero only, as the capacitor C_1 would be acting as an open circuit. This kind of behavior exhibited by the Wien-Bridge network makes it a lead-lag circuit in the case of low and high frequencies, respectively.

Phase Shift Oscillators:-

RC phase-shift oscillators use resistor-capacitor (RC) network (Figure 1) to provide the phase- shift required by the feedback signal. They have excellent frequency stability and can yield a pure sine wave for a wide range of loads.

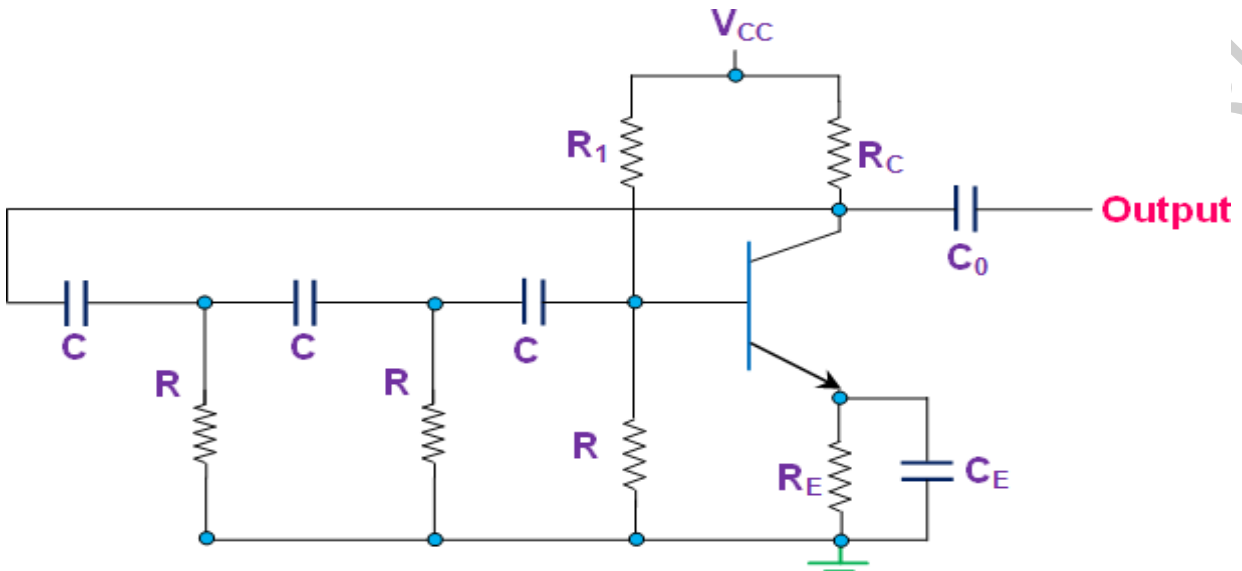

Figure 2 RC Phase-Shift Oscillator Using BJT

Ideally a simple RC network is expected to have an output which leads the input by 90° . However, in reality, the phase-difference will be less than this as the capacitor used in the circuit cannot be ideal. Mathematically the phase angle of the RC network is expressed as

$$\varphi = \tan^{-1} \frac{X_C}{R}$$

Where, $X_C = 1/(2\pi fC)$ is the reactance of the capacitor C and R is the resistor. In oscillators, these kind of RC phase-shift networks, each offering a definite phase-shift can be cascaded so as to satisfy the phase-shift condition led by the Barkhausen Criterion.

Here the collector resistor RC limits the collector current of the transistor, resistors R₁ and R (nearest to the transistor) form the voltage divider network while the emitter resistor R_E improves the stability. Next, the capacitors C_E and C_o are the emitter by-pass capacitor and the output DC decoupling capacitor, respectively. Further, the circuit also shows three RC networks employed in the feedback path.

Procedure:-

1. We should take all the components for this experiment.
2. Make the connection as per circuit diagram.
3. Switch ON the kit using ON/OFF toggle switch
4. The input signal is applied with the function generator.
5. Then observe the wave form.
6. Then trace the wave form.
7. Calculate the frequency.

Conclusion: - From the above experiment, we learnt about the different types of oscillator.

GOVT. POLYTECHNIC, NAYAGARH

Experiment - 12

Aim- Construct & Test Differentiator and Integrator using R-C circuit.

APPARATUS REQUIRED:

SI. No	Name of the Equipment	Specification	Quantity
1	Capacitor	220 p F / 2.2 μ F	1no
2	Resistor	5.6 K Ω	1no
3	Signal Generator	1 KHz	1no
4	CRO	2 KHz	1no
5	Connecting Wires	-	As Per Required

Theory:-

1. DIFFERENTIATOR WITH INPUT FREQUENCY 1 KHZ

Input voltage is 20 v pp.

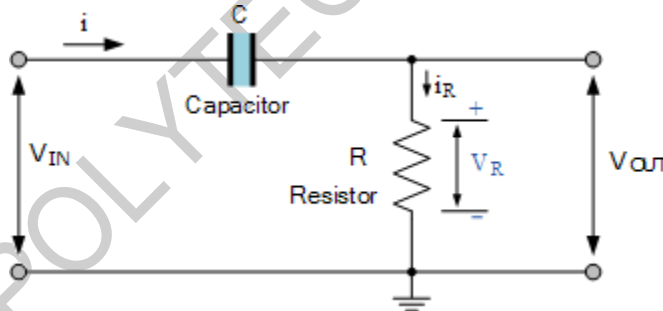

DESIGN

$RC < 0.0016T$; Take $R = 5.6 \text{ K}$ (To avoid the loading R should be more than ten times the resistance of signal generator) So $C = 220 \text{ p F}$ ($T = 1 \text{ ms}$ because the input frequency is 1 kHz)

2. INTEGRATOR

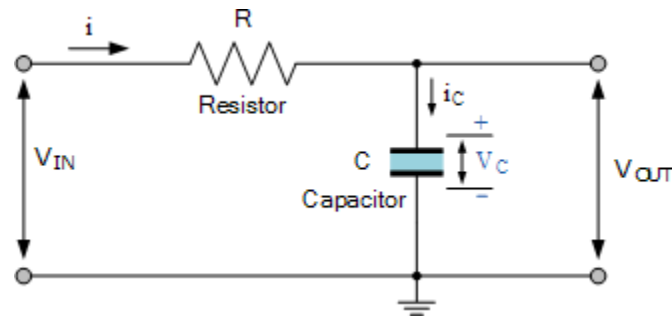

DESIGN

$$RC > 16T$$

$T = 1 \text{ ms}$, Take $R = 5.6 \text{ K}$ to avoid loading effect of signal generator.

So $C = 2.2 \text{ uF}$ (approximately)

THEORY:-

A differentiator gives the derivative of input voltage as output. A differentiator using passive components resistors and capacitors is a high pass filter. The circuit is shown. It acts as a differentiator only when the time constant is too small. The voltage at output is proportional to the current through the capacitor. The current through the capacitor can be expressed as $C \frac{dv}{dt}$. The output is taken across the resistor. So output will be $RC \frac{dv}{dt}$. Thus differentiation of input takes place.

When a square wave is applied at the input, during the positive half cycle capacitor charges. So initially the voltage across the resistor will be the applied voltage. As the capacitor charges, the voltage across resistor decreases.

Now consider the case of integrator. It is a low pass filter. Here the time constant of the circuit should be very large. Here output is taken across the capacitor. As the input square wave is applied, during the positive half cycle the voltage across capacitor increases from zero, to the maximum (peak value of applied voltage). During the negative half cycle, the capacitor starts to discharge and comes to zero. This process repeats for the remaining cycles and a triangular wave is obtained.

PROCEDURE: -

1. Set up the differentiator circuit.
2. Apply the square wave of 5V pp at 1 KHz.

3. Observe the output and plot it.
4. Do the above steps for differentiator also.

WAVE FORMS: -

1. DIFFERENTIATOR

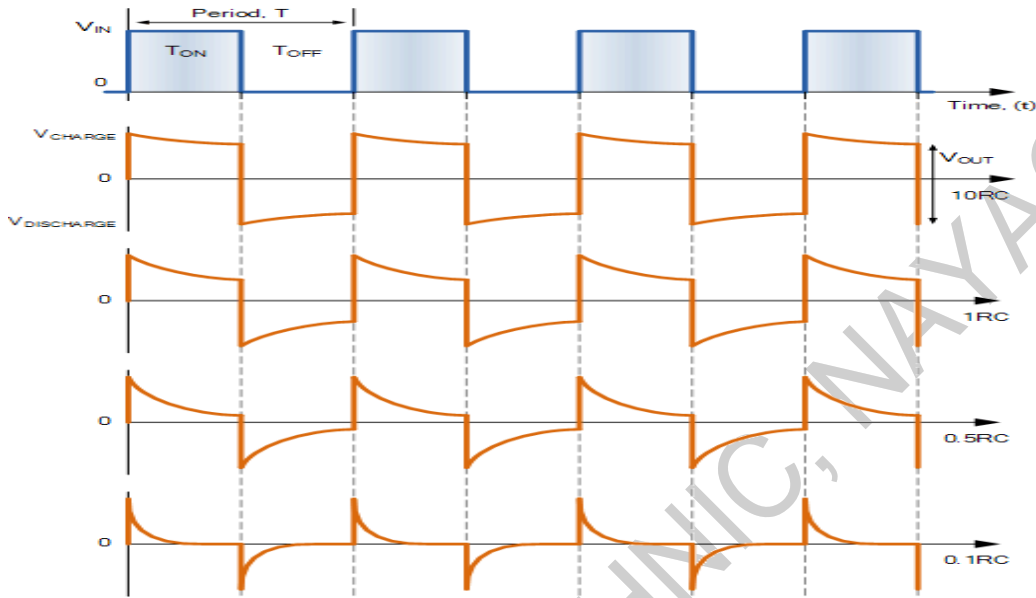

2. INTEGRATOR

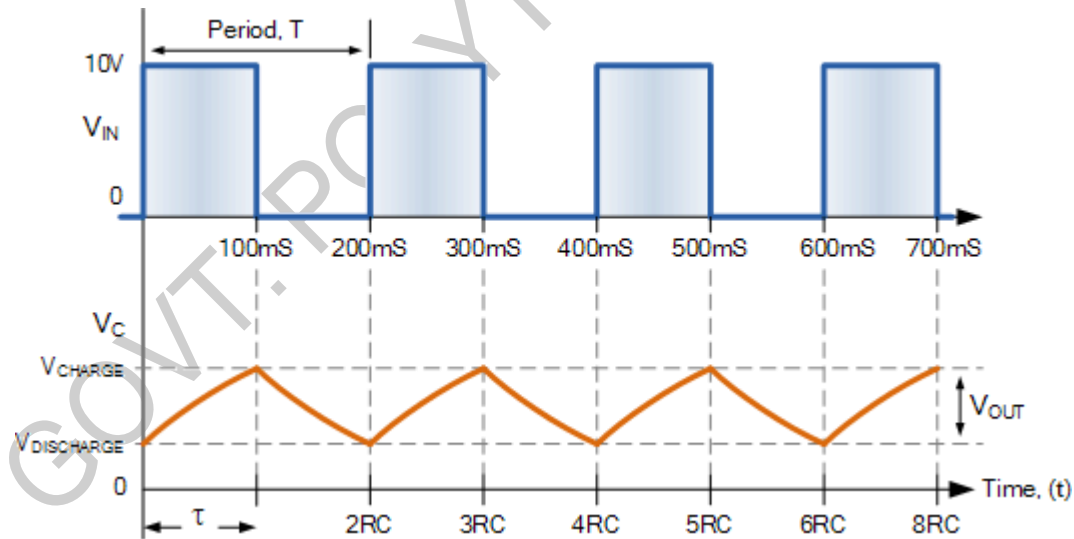

Conclusion: - From the above experiment, we learnt about the construct & test of differentiator and integrator using R-C circuit.

Experiment - 13

Aim- Study Multivibrator (Astable, Bistable, Monstable) circuits & draw its wave forms.

APPARATUS REQUIRED:

Sl. No	Name of the Equipment	Specification	Quantity
1	Multivibrator Trainer Kit	-	1no
2	CRO	2 KHz	1 no
3	Function Generator	2 KHz	1 no
4	Connecting Probes	-	As Per Required

Theory:-

Multivibrator: -

A Multivibrator is a two-stage resistance coupled amplifier with positive feedback from the output of one amplifier to the input of the other.

Two transistors are connected in feedback so that one controls the state of the other. Hence the ON and OFF states of the whole circuit, and the time periods for which the transistors are driven into saturation or cut off are controlled by the conditions of the circuit

Types of Multivibrators: -

1. Astable Multivibrator
2. Bistable Multivibrator
3. Monstable Multivibrator

Astable Multivibrator: -

An astable multivibrator has no stable states. Once the multivibrator is ON, it just changes its states on its own after a certain time period which is determined by the R_C time constants. A dc power supply or V_{cc} is given to the circuit for its operation.

Two transistors named Q_1 and Q_2 are connected in feedback to one another. The collector of transistor Q_1 is connected to the base of transistor Q_2 through the capacitor C_1 and vice versa. The emitters of both the transistors are connected to the ground. The collector load resistors

R_1 and R_4 and the biasing resistors R_2 and R_3 are of equal values. The capacitors C_1 and C_2 are of equal values.

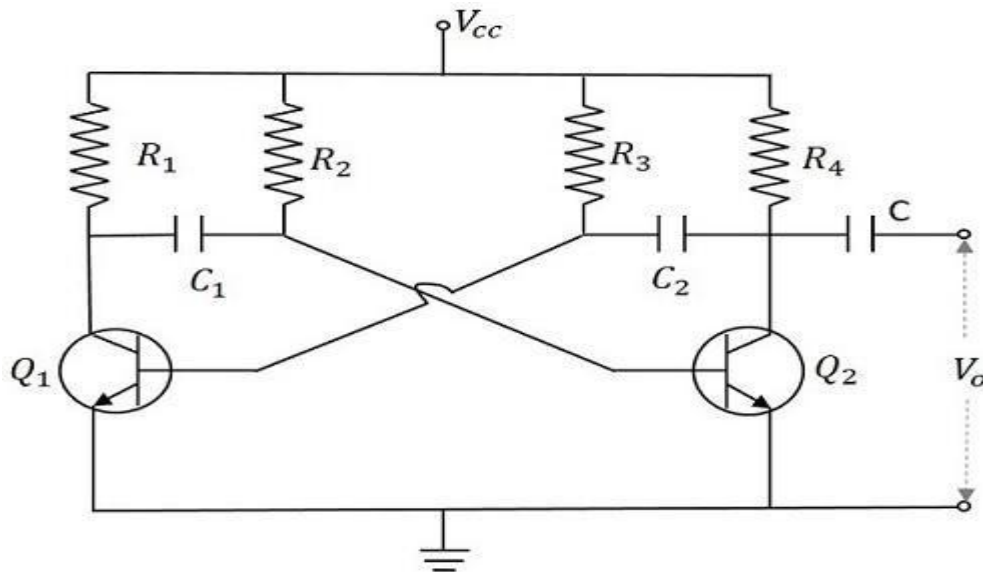

[Circuit Diagram of Astable Multivibrator]

Monostable Multivibrator: -

A monostable multivibrator, as the name implies, has only one stable state. When the transistor conducts, the other remains in non-conducting state. A stable state is such a state where the transistor remains without being altered, unless disturbed by some external trigger pulse. As Monostable works on the same principle, it has another name called as One-shot Multivibrator.

Two transistors Q_1 and Q_2 are connected in feedback to one another. The collector of transistor Q_1 is connected to the base of transistor Q_2 through the capacitor C_1 . The base Q_1 is connected to the collector of Q_2 through the resistor R_2 and capacitor C . Another dc supply voltage $-V_{BB}$ is given to the base of transistor Q_1 through the resistor R_3 . The trigger pulse is given to the base of Q_1 through the capacitor C_2 to change its state. R_{L1} and R_{L2} are the load resistors of Q_1 and Q_2 .

One of the transistors, when gets into a stable state, an external trigger pulse is given to change its state. After changing its state, the transistor remains in this quasi-stable state or Meta-stable state for a specific time period, which is determined by the values of RC time constants and gets back to the previous stable state.

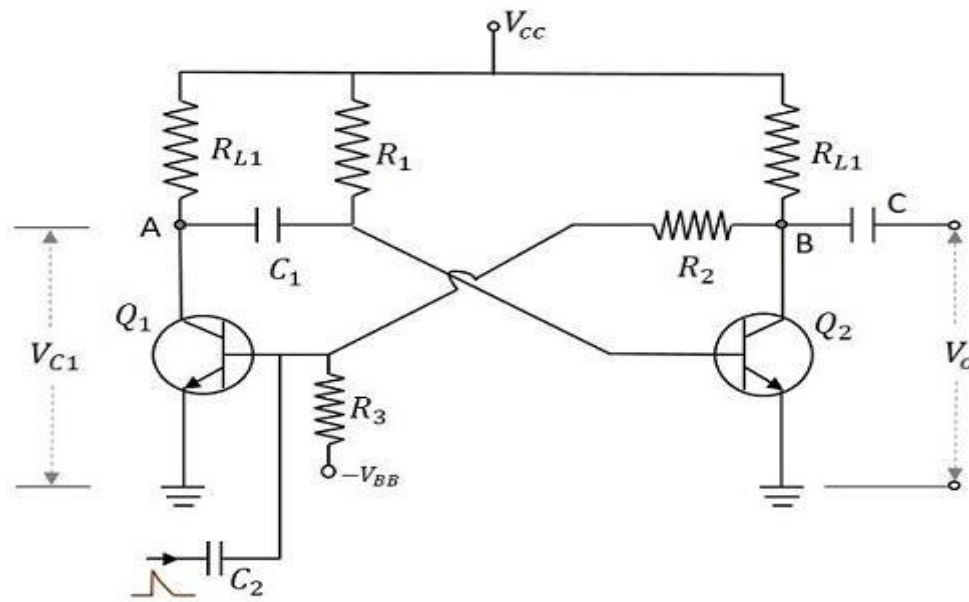

[Circuit Diagram of Monostable Multivibrator]

Bistable Multivibrator: -

A Bistable Multivibrator has two stable states. The circuit stays in any one of the two stable states. It continues in that state, unless an external trigger pulse is given. This Multivibrator is also known as Flip-flop. This circuit is simply called as Binary.

Two similar transistors Q_1 and Q_2 with load resistors R_{L1} and R_{L2} are connected in feedback to one another. The base resistors R_3 and R_4 are joined to a common source $-V_{BB}$. The feedback resistors R_1 and R_2 are shunted by capacitors C_1 and C_2 known as Commutating Capacitors. The transistor Q_1 is given a trigger input at the base through the capacitor C_3 and the transistor Q_2 is given a trigger input at its base through the capacitor C_4 .

The capacitors C_1 and C_2 are also known as Speed-up Capacitors, as they reduce the transition time, which means the time taken for the transfer of conduction from one transistor to the other.

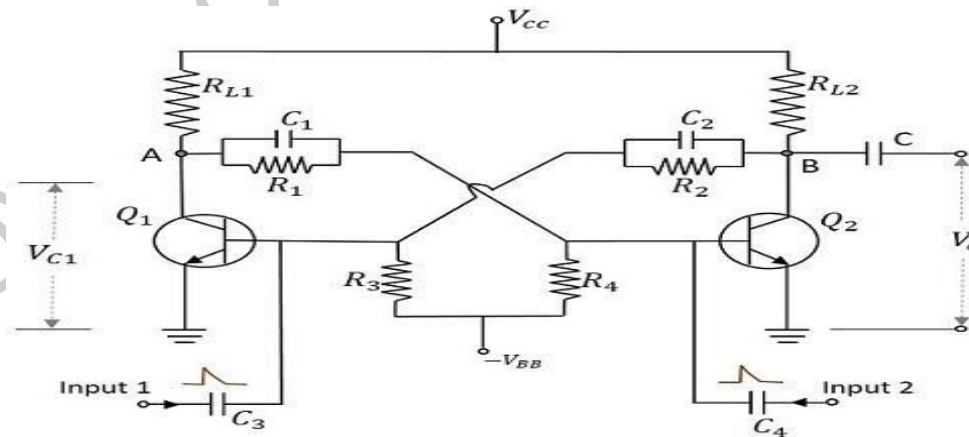

[Circuit Diagram of Bistable Multivibrator]

Wave Forms:-

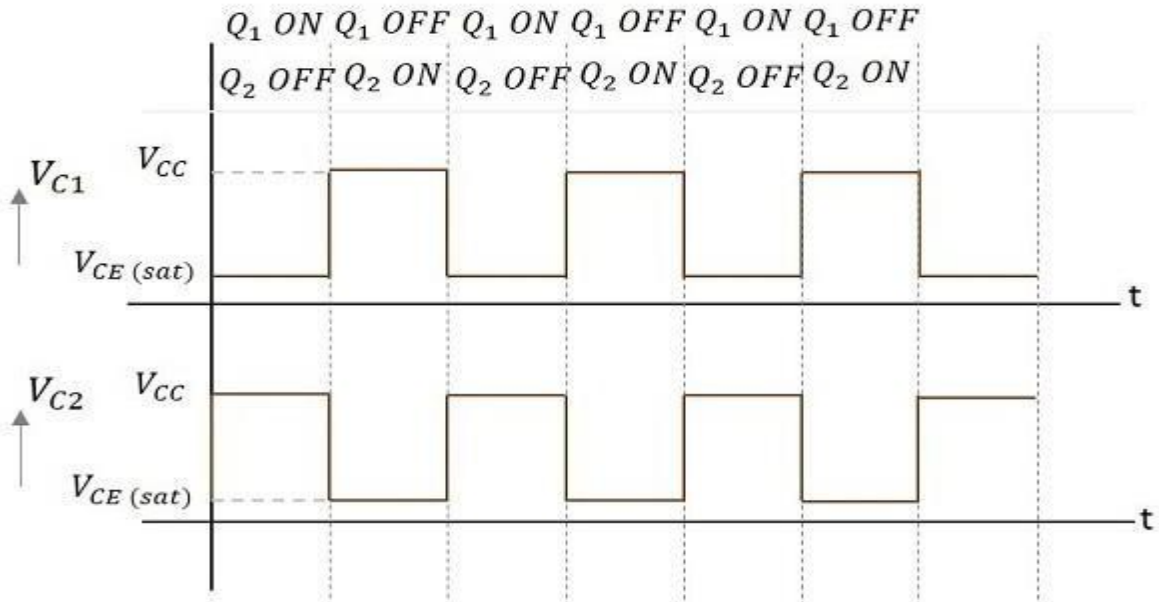

[Wave form of Astable Multivibrator]

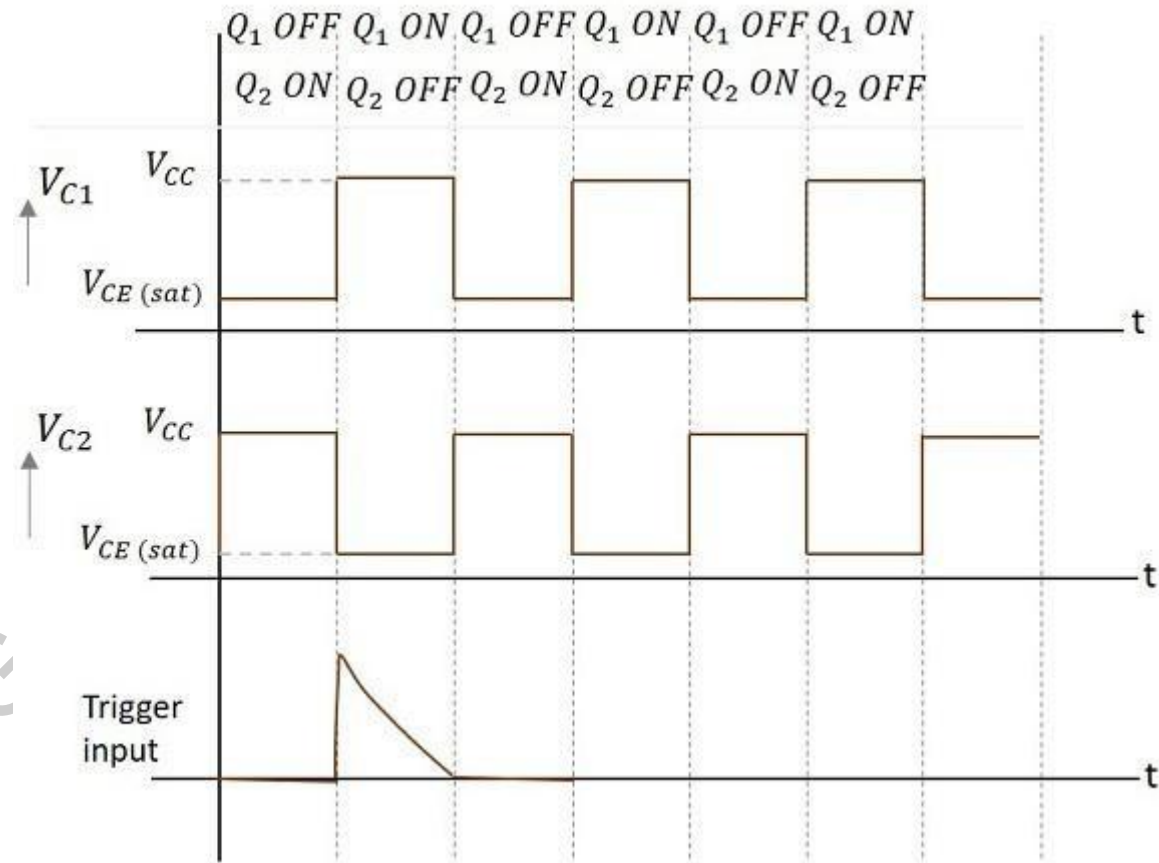

[Wave form of Bistable Multivibrator]

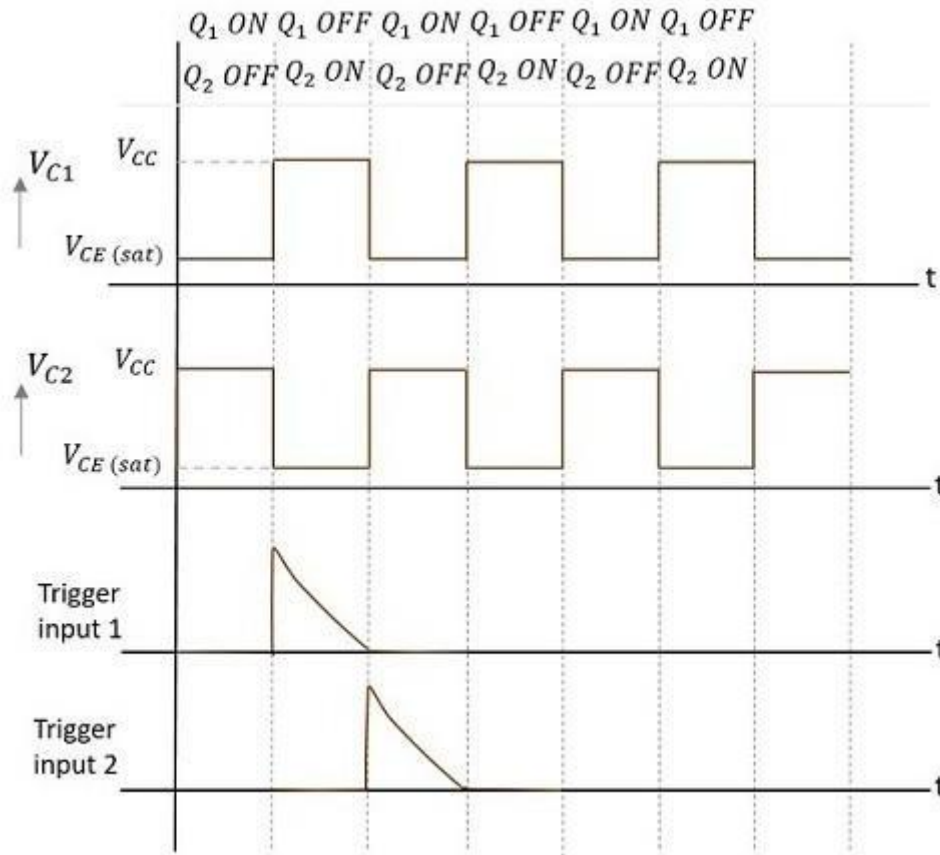

[Wave form of Monstable Multivibrator]

Procedure:-

1. Connect the circuit as per the circuit diagrams shown in connection diagram.
2. Verify the stable states.
3. Apply the square wave of 2Vp-p, 1 KHz signal to the trigger circuit from external function generator.
4. Observe the wave forms at base of each transistor simultaneously.
5. Observe the wave forms at collectors of each transistor simultaneously.
6. Note down the parameters carefully.
7. Note down the time period and compare it with theoretical values.
8. Plot the wave forms.

Conclusion:- From the above experiment, we learnt about the circuit diagram and wave forms of multivibrators.